

REV.	DATE	DESCRIPTION
NC	07/13/04	INITIAL RELEASE
A	01/20/08	REMOVE NOTES, REVISE INSULATOR TO DELRIN.

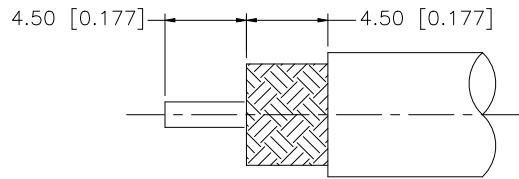

RECOMMENDED CABLE STRIPPING DIMS

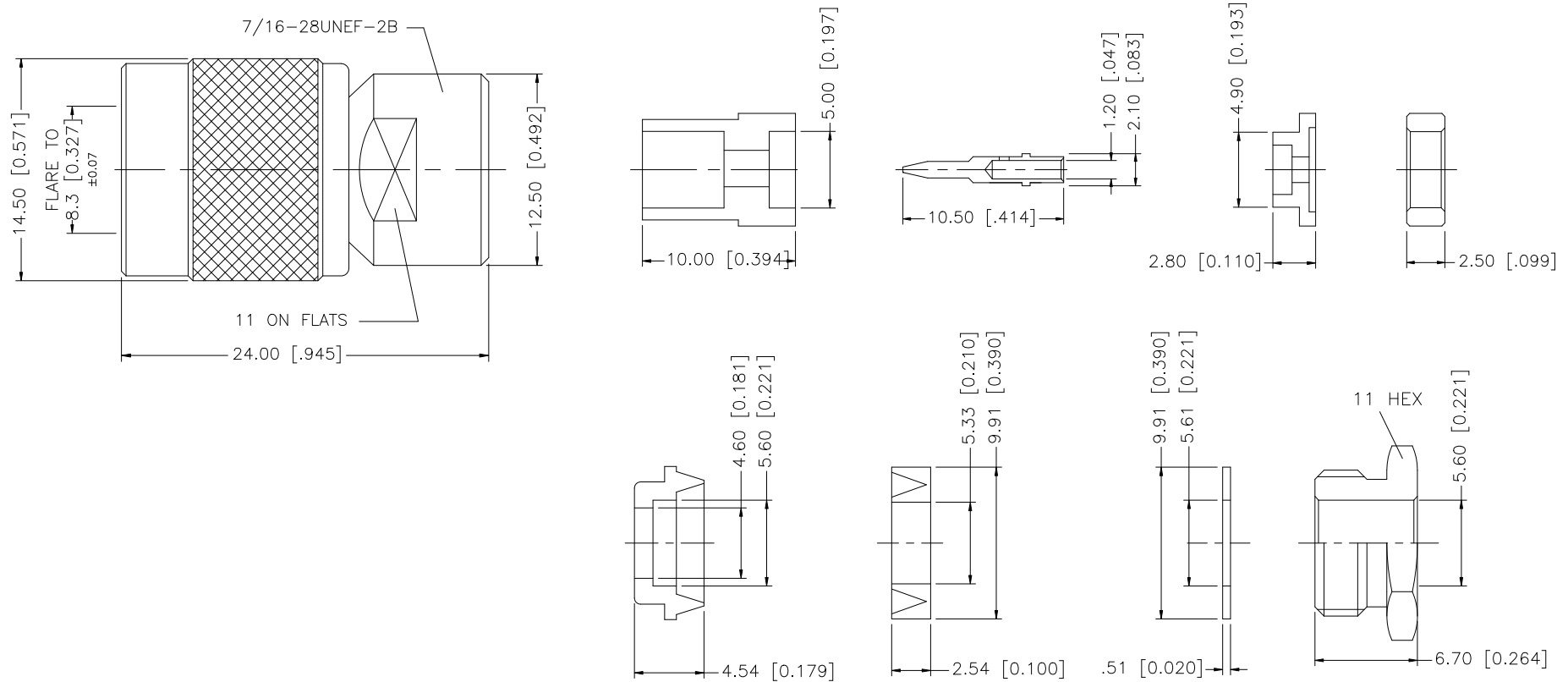

QTY	DESCRIPTION	MATERIAL	FINISH	QTY
8				
7	CONTACT PIN	BRASS	NICKEL	1
6	HEX NUT	BRASS	NICKEL	1
5	WASHER	BRASS	NICKEL	1
4	GASKET	SILICONE	RED	1
3	BRAID CLAMP	BRASS	NICKEL	1
2	INSULATOR	DELRIN	NATURAL	1
1	BODY	BRASS	NICKEL	1

UNLESS OTHERWISE SPECIFIED DIMENSIONS ARE IN MILLIMETERS. DIMENSIONS IN [] ARE IN INCHES AND FOR CUSTOMER REFERENCE ONLY.

UNLESS OTHERWISE SPECIFIED TOLERANCES FOR MILLIMETERS ARE:
0.5 - 8mm ± 0.20mm
8 - 30mm ± 0.40mm
30 - 120mm ± 0.50mm

UNLESS OTHERWISE SPECIFIED TOLERANCES FOR INCHES ARE:
.020 - .315 = ± 0.007"
.315 - 1.180 = ± 0.015"
1.180 - 4.724 = ± 0.020"

DO NOT SCALE DRAWING

APPROVALS	DATE
DRAWN G.R.S.	01/20/08
CHECKED	
ISSUED	
SHEET 1 OF 1	
CAD FILE	C:/122/122274.DWG

PART DESCRIPTION			
Amphenol Connex			
TNC CLAMP PLUG (FOR RG-58C/U, 58/U, 142A/U, 223/U CABLE)			
PART NO. 122274			
DWG. NO.	122274.DWG	REV. A	SCALE NA