

THIS DRAWING IS UNPUBLISHED.		RELEASED FOR PUBLICATION	
© COPYRIGHT BY TYCO ELECTRONICS CORPORATION.		ALL RIGHTS RESERVED.	
PART NUMBER	REV	FIRST USED	
566207-1	E	1-471273-3	

LOC	DIST	REVISIONS					
A	-	P	LTR	DESCRIPTION	DATE	DWN	APVD
		E2		ECN 0150-0221-05	3-05	MY	TE

APPLICATOR PARTS LIST				TYPE LENGTHWISE AMPLIVAR SPLICE PIGTAIL			CRIMPING DATA		TERMINALS
NO.	DESCRIPTION	REQ.	PART NO.	NO.	DESCRIPTION	REQ.	PART NO.		
1	WIRE CRIMPER	1	455713-7	42	SCREW, SHC	2	811651-5	TO APPLY TERMINAL	62308
2	INS. CRIMPER	-	-	43	WASHER, LOCK	2	21057-4	SPEC 114-2003	62346
3	ANVIL	1	455714-7	44	STRIP, HOLD DOWN	1	810640-1	WIRE SIZE	CRIMP HEIGHT
4	ANVIL SPACER	-	-	45	-	-	-	(2)#17 MAG	.080±.002
5	SHEAR BLADE	1	693012-1	46	-	-	-		
6	REAR SHEAR PLATE	1	465891-1	47	-	-	-		
7	SHEAR BLADE SPACER	-	-	48	-	-	-		
8	FRONT SHEAR PLATE	-	-	49	-	-	-		
9	REAR ANVIL SPACER PL	-	-	50	DRAG BUSHING -FRONT	1	452836-1	CRIMP	SIZE
10	FRONT ANVIL SPACER PL	-	-	51	DRAG SCREW -FRONT	1	452837-1	WIRE	.140
11	TOOL SPACER	-	-	52	DRAG SPRING -FRONT	1	370572		F
12	CRIMP SPACER	-	-	53	-	-	-		BLUNT
13	FRONT STRIP GUIDE	1	1-691311-4	54	-	-	-		.345
14	REAR STRIP GUIDE	1	1-691311-5	55	ELBOW	1	22317-3	INSULATION RANGE	WIRE RANGE
				56	TUBE, COPPER	1	689446-2	-	3000 - 7000 CMA
15	RAM	1	471167	57	SCREW, SHC	1	21001-4	EXPLODED VIEW	
16	TOOL HOLDER	1	689633-2	58	-	-	-	REMARKS:	
17	CRIMPER & BLADE MOUNT	1	465755-2	59	WASHER, LOCK	1	21024-6	RECOMMENDED SPARE PARTS	
18	SCREW, SHC	1	3-21000-6	60	-	-	-	PLACE ITEM 66 BETWEEN CRIMP HOLDER ITEM 17 & ALIGN GAGE	
19	APPLICATOR MOUNT ASSY.	1	471707-4	61	LUBRICATOR ASSEMBLY	1	465184-2	3. TOP TOOL MOUNTING FROM TOOL HOLDER (16) OUTWARD ITEM 17, 5 & 1	
20	BASE PLATE	-	-	62	-	-	-	4. .800 FORWARD	
21	BASE BLOCK	-	-	63	AIR BLAST ASSEMBLY	1	455350-2	5. SPECIAL FLAT ON CRIMPER AND .165 ANVIL	
22	STRIP GUIDE PLATE	-	-	64	-	-	-	6. ALIGN GAGE 679597-1	
23	ANVIL HOLDER	-	-	65	TENSION ADJ. PLATE	1	374999	SET-UP ONLY.	
24	AUX. ANVIL HOLDER	-	-	MISCELLANEOUS					
25	STRIPPER - GUARD	1	389072-3	66	TOOL SPACER (SETUP ONLY)	-	693619-1		
26	STRIPPER MOUNT	-	-	67	-	-	-		
27	RETAINER PLATE	-	-	68	-	-	-		
28	STRIPPER MOUNT BRACKET	-	-	69	-	-	-		
29	STRIPPER BUSHING	-	-	70	-	-	-		
30	STOCK DRAG	1	376666	71	-	-	-		
31	STOCK DRAG HANDLE	-	-	72	-	-	-		
32	STOCK DRAG STUD, REAR	1	354045-1						
33	STOCK DRAG SPRING, REAR	1	1-23847-1						
34	STOCK DRAG ADJ. SCREW	2	372997						
35	FEED FINGER HOLDER	-	-						
36	FEED FINGER	1	452817-1						
37	FEED FINGER TIP	-	-						
38	FEED FINGER SPACER	-	-						
39	BASE CASTING	1	570238						
40	GUARD	1	460182-1						
41	-	-	-						

THIS APPLICATOR IS TO BE USED ON  
AMP-O-ELECTRIC 1-471273-3  
MECH. FEED

THIS DRAWING IS A CONTROLLED DOCUMENT.		DWN	08MAR05	Tyco Electronics Corporation Harrisburg, Pa 17105-3608
FINISH -		M. YOUNGER	11MAR05	
DIMENSIONS: INCHES		CHK	T. ELBIN	END FEED STD APPLICATOR
TOLERANCES UNLESS OTHERWISE SPECIFIED:		APVD	T. ELBIN	
0 PLC ± -		PRODUCT SPEC		SIZE
1 PLC ± -		APPLICATION SPEC		
2 PLC ± -				DRAWING NO
3 PLC ± -				RESTRICTED TO
4 PLC ± -				SCALE
ANGLES ± -				SHEET
FINISH				OF
MATERIAL		WEIGHT		REV
				E2
		CUSTOMER DRAWING		

566207-1



THIS DRAWING IS UNPUBLISHED. RELEASED FOR PUBLICATION  
 © COPYRIGHT BY TYCO ELECTRONICS CORPORATION. ALL RIGHTS RESERVED.

LOC	DIST	REVISIONS					
A	-	P	LTR	DESCRIPTION	DATE	DWN	APVD
		-	-	SEE SHEET 1	-	-	-

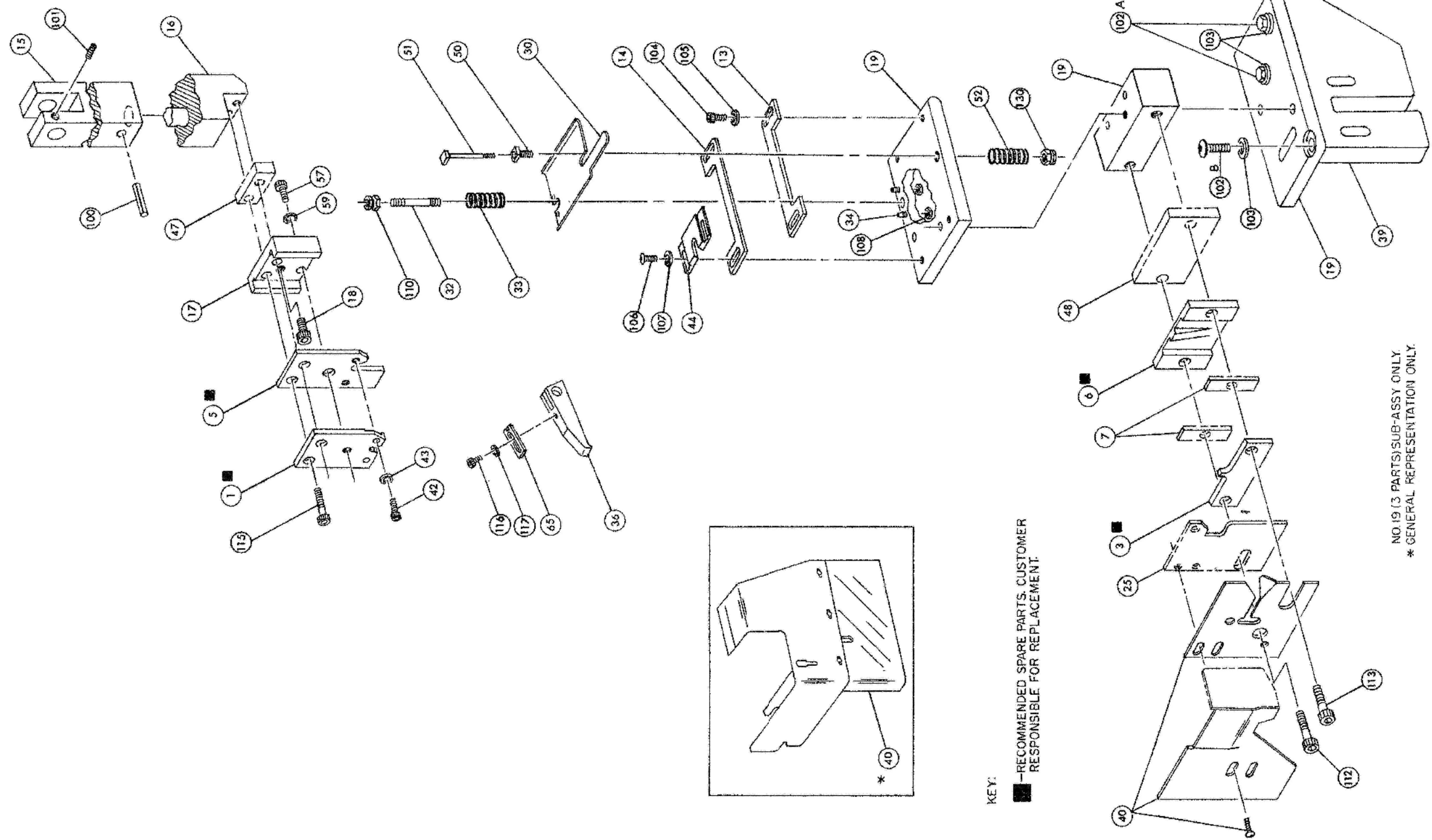

NO. 19 (3 PARTS) SUB-ASSY ONLY.  
 \* GENERAL REPRESENTATION ONLY.

KEY:  
 ■ —RECOMMENDED SPARE PARTS. CUSTOMER RESPONSIBLE FOR REPLACEMENT.

THIS DRAWING IS A CONTROLLED DOCUMENT.		DWN	08MAR05	<b>tyco</b> Electronics	Tyco Electronics Corporation	
FINISH -		M. YOUNGER	11MAR05		Harrisburg, Pa 17105-3608	
DIMENSIONS: INCHES		CHK	T. ELBIN	NAME		
TOLERANCES UNLESS OTHERWISE SPECIFIED:		APVD	T. ELBIN	END FEED STD APPLICATOR		
0 PLC		PRODUCT SPEC		SIZE	CAGE CODE	DRAWING NO
1 PLC		APPLICATION SPEC		A2	00779	C-566207-1
2 PLC		WEIGHT		RESTRICTED TO		
3 PLC		CUSTOMER DRAWING		SCALE - SHEET 3 OF 4 REV E2		
4 PLC						
ANGLES						
FINISH						

4 3 2 1

THIS DRAWING IS UNPUBLISHED. RELEASED FOR PUBLICATION  
 © COPYRIGHT BY TYCO ELECTRONICS CORPORATION. ALL RIGHTS RESERVED.

LOC		DIST		REVISIONS			
P	LTR	DESCRIPTION	DATE	DWN	APVD		
A	-	SEE SHEET 1	-	-	-		

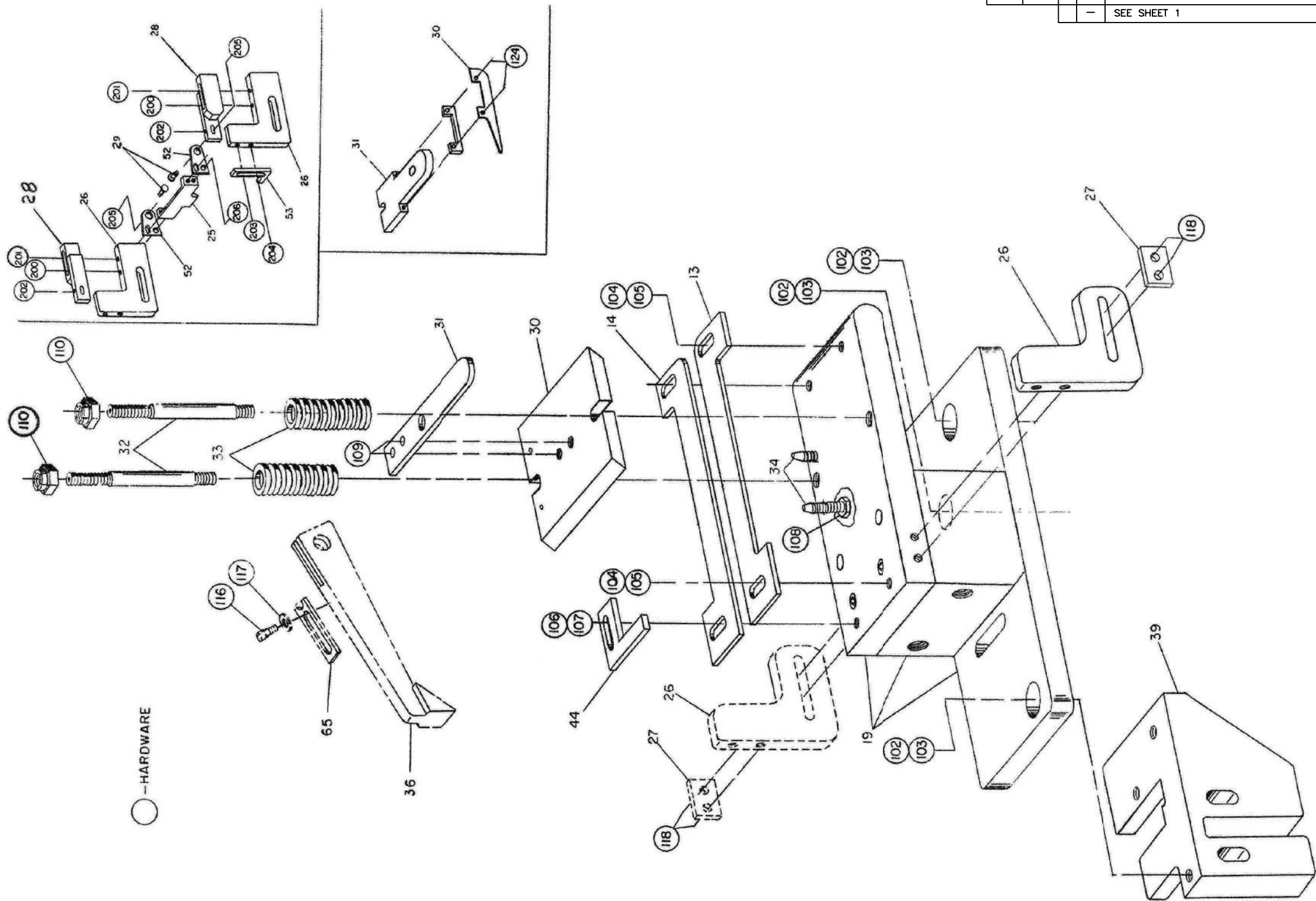

○ - HARDWARE

THIS DRAWING IS A CONTROLLED DOCUMENT.		DWN	08MAR05	<b>tyco</b> Electronics	Tyco Electronics Corporation	
FINISH -		M. YOUNGER	11MAR05		Harrisburg, Pa 17105-3608	
DIMENSIONS: INCHES		CHK	T. ELBIN	NAME		
TOLERANCES UNLESS OTHERWISE SPECIFIED:		APVD	T. ELBIN	PRODUCT SPEC		
0 PLC ± -		APPLICATION SPEC		END FEED STD APPLICATOR		
1 PLC ± -		WEIGHT		SIZE	CAGE CODE	DRAWING NO
2 PLC ± -		CUSTOMER DRAWING		A2	00779	C-566207-1
3 PLC ± -		SCALE		RESTRICTED TO		
4 PLC ± -		SHEET		4 OF 4		
ANGLES ± -		REV		E2		
FINISH						

566207-1