

General Description

The MP1010B is a power solution IC that offers a true complete solution for driving a Cold Cathode Fluorescent Lamps (CCFL). This Power IC converts unregulated DC voltage to a nearly pure sine wave required to ignite and operate the CCFL. Based on proprietary power topology and control techniques it greatly increases the power conversion efficiency. The MP1010B is covered by patent numbers 6,633,138, 6,316,881, and 6,114,814.

Ordering Information

Part Number*	Package	Temperature
MP1010BEM	TSSOP20	-20°C to +85°C
MP1010BEF	TSSOP20F	-20°C to +85°C
EV0037	MP1010BEM Evaluation Board	

* For Tape & Reel use suffix - Z (e.g. MP1010BEM-Z)

Features

- Integrated power switches
- 6.0 to 23V variable supply voltage with regulated lamp current.
- Rated 12W power output at 12V input
- Open lamp regulation
- Current and Voltage feedback control
- Logic Level burst mode control
- Supports Open/Short Lamp protection
- Soft Start
- Output is short circuit protected
- High Energy Start Pulse
- Analog and Burst Mode Dimming
- **Evaluation Board Available**

Applications

- LCD Backlight inverter for notebook computers, Web Pads, GPS, desktop display, Portable DVD, Car Video display system.

Figure 1: Typical Application Circuit

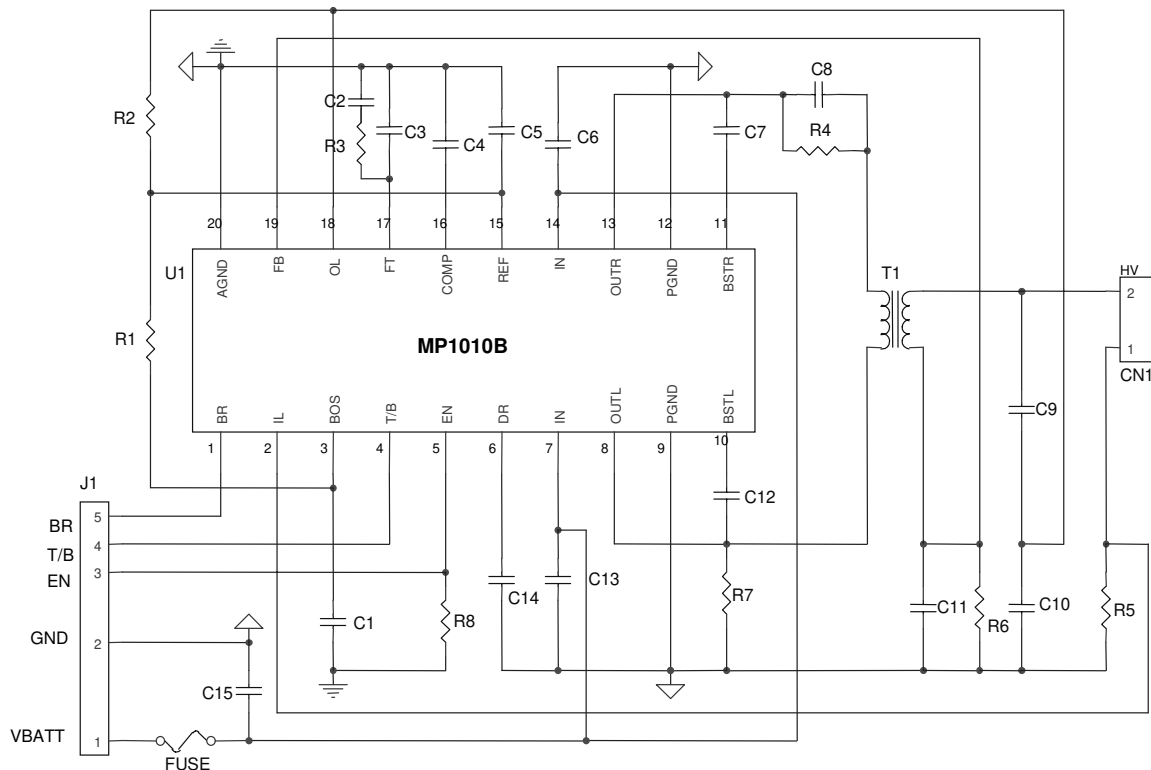

Absolute Maximum Ratings

Input Voltage (V_{IN})	25V
IL, FB Input Voltages (V_{IL} , V_{FB})	+/-6V
OL Input Voltage (V_{OL})	-0.3V to 12V
Logic Input Voltages	-0.3V to 6.8V
Power Dissipation	1.0W
Operating Frequency	150KHz
Junction Temperature	150°C
Lead Temperature (Solder)	260°C
Storage Temperature	-55°C to 150°C

Recommended Operating Conditions

Input Voltage (V_{IN})	6V to 23V
Analog Brightness Voltage (V_{BR})	0V to 1.9V
Digital Brightness Voltage ($V_{T/B}$)	0V to 1.8V
Enable (V_{EN})	0V to 5V
Operating Frequency (Typical)	60KHz
Ambient Operating Temperature	-20°C to +85°C

Thermal Characteristics

	θ_{JA}	θ_{JC}
Thermal Resistance (TSSOP)	90°	25° C/W
Thermal Resistance (TSSOPF)	40°	6° C/W

Electrical Characteristics (Unless otherwise specified $V_{IN}=12V$, $T_A=25^\circ C$)

Parameters	Symbol	Condition	Min	Typ	Max	Units
Reference Voltage						
Output Voltage	V_{REF}	$I_{REF} = 3mA$	4.75	5.0	5.25	V
Reference Current	I_{REF}				3.0	mA
Line Regulation		$6.5V < V_{IN} < 23V$			30	mV
Load Regulation		$0 < I_{REF} < 3.0mA$			30	mV
Output Drivers						
Switch On Resistance	$R_{(ON)}$	(Note 1)	0.08	0.11	0.14	Ω
Short Circuit Current	I_{SC}			4		A
Ton(min)		$V_{COMP}=0V, V_{IN}=23V$		435	550	ns
Ton(min)		$V_{COMP}=0V, V_{IN}=6V$		1750	2100	ns
Battery Supply						
Supply Current (quiescent)	$I_{CC(OFF)}$				10	μA
Supply Current (operating)	$I_{CC(ON)}$	$V_{IN}=23V$		1.8	2.5	mA
Brightness Control						
Sense full Brightness	V_{IL}	$V_{BR}= 2.0V$	360	379	400	mV
Sense full Dim	V_{IL}	$V_{BR}= 0V$	105	117	130	mV
Lamp Current regulation		$7V < V_{IN} < 23V$		2	5	%
Burst Oscillator Peak Voltage	V_{BOS}		1.70	1.78	1.86	V
Digital Brightness Offset Voltage	$V_{(OS) T/B}$		-50	5	50	mV
Fault Detect						
Open Lamp Threshold	$V_{(TH)OL}$			0		V
Secondary Current Threshold	$V_{(TH)FB}$			1.2		V
Fault Mode COMP Current	I_{COMP}	$V_{OL}<0V, V_{FB}>1.2V$		475		μA
Shutdown Logic						
Fault Timer Threshold	$V_{(TH)FT}$		1.1	1.2	1.3	V
Fault Timer Sink Current		$V_{OL}>0, V_{FB}<1.2V$		1		μA
Fault Timer Source Current						
Open Lamp		$V_{OL}<0, V_{FB}<1.2V$		1		μA
Secondary Overload		$V_{FB}>1.2V$		120		μA
Enable Voltage Low	$V_{(L)EN}$				0.5	V
Enable Voltage High	$V_{(H)EN}$		2.0			V

Note 1: This parameter is guaranteed by design.

Pin Description

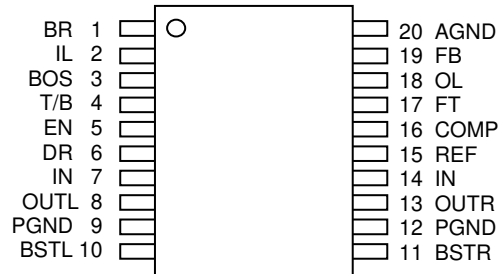

Table 1: Pin Designators

Pin Number	Pin Name	Pin Function
1	BR	Analog Dimming
2	IL	Lamp Current Feedback Sense Input
3	BOS	Burst Oscillator Timing
4	T/B	Test/Burst Mode Dimming
5	EN	Chip Enable. Do not float this pin.
6	DR	Internally Generated MOSFET Gate Drive Supply Voltage (6V)
7	IN	Power Supply Input
8	OUTL	Output to Load (tank circuit)
9	PGND	Power Ground
10	BSTL	Regulated Output Voltage for Bootstrap Capacitor on Phase L
11	BSTR	Regulated Output Voltage for Bootstrap Capacitor on Phase R
12	PGND	Power Ground
13	OUTR	Output to Load (tank circuit)
14	IN	Power Supply Input
15	REF	Internally Generated Reference Voltage Output (5V)
16	COMP	Loop Compensation Capacitor
17	FT	Fault Timer
18	OL	Open Lamp Detect (Lamp Voltage Feedback.)
19	FB	Shorted Lamp Detect (Secondary Current Feedback)
20	AGND	Small Signal Ground (Note 1)

Note 1: For the MP1010BEF, connect the exposed paddle to AGND (Pin 20).

Feature Description

Brightness Control

The MP1010B can operate in three modes:

1. Analog Mode
2. Burst Mode with a DC input
3. Burst Mode with an external PWM.

The three modes are dependent on the pin connections as per Table 1.

The MP1010B has a soft on and soft off feature to reduce noise, when using burst mode dimming.

Table 1: Function Mode

Function	Pin Connection		
	Pin 1	Pin 4	Pin 3
	BR	T/B	BOS
Analog Mode	0 – 1.9V	V _{REF}	AGND
Burst Mode with DC input voltage	V _{REF}	0 – 1.8V	R1 C1
Burst Mode from external source	V _{REF}	PWM	1.5V

Brightness Polarity:

Burst: 100% duty cycle is at 1.8V

Analog: 1.9V is maximum brightness

Choosing the required burst repetition frequency can be achieved by an RC combination, as defined in component selection.

Chip Enable

The chip has an on / off function, which is controlled by the EN pin (#5). The enable signal goes directly to a Schmitt trigger. The chip will turn ON with an EN = High and OFF with an EN = Low.

Fault Protection

Open Lamp: The OL pin (#18) is used to detect whether an open lamp condition has occurred. During normal operation the OL pin is typically at 5V DC with an AC swing of +/- 2V. If an open lamp condition exists then the AC voltage on the OL line will swing below zero volts. When that occurs, the IC regulates the OL voltage to 10V p-p and a 1μA current source will inject into the FT pin. If the voltage at the FT pin exceeds 1.2V, the chip will shut down.

Excessive Secondary Current (Shorted Lamp and UL safety specs): The FB pin (#19) is used to detect whether excessive secondary current has occurred. During normal operation the FB voltage is a 1V p-p AC signal centered at zero volts D.C. If a fault condition occurs that increases the secondary current, then the voltage at FB will be greater than 1.2V. When that occurs, the IC regulates the FB voltage to 2.4V p-p and a 120μA current source will inject into the FT pin. If the voltage at the FT pin exceeds 1.2V, the chip will shut down.

Lamp Startup

The strike voltage of the lamp will always be guaranteed at any temperature because the MP1010B uses a resonant topology for switching the outputs. The device will continue to switch at the resonant frequency of the tank until the strike voltage is achieved. This eliminates the need for external ramp timing circuits to ensure startup.

Fault Timer

The timing for the fault timer will depend on the sourcing current, as described above, and the capacitor on the FT pin. The user can program the time for the voltage to rise before the chip detects a “real” fault. When a fault is triggered, then the internal drive voltage (V_{DR}) will collapse from 6.2V to 0V. The reference voltage will stay high at 5.0V.

Packaging Information

TSSOP20 or TSSOP20F (Exposed Paddle **)

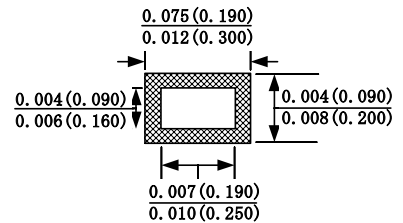
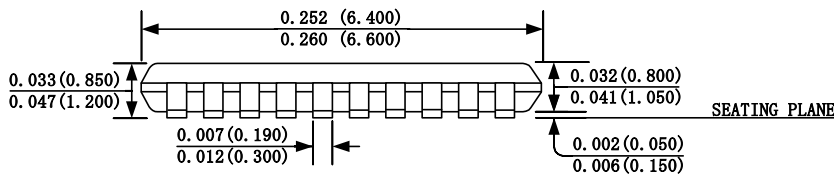
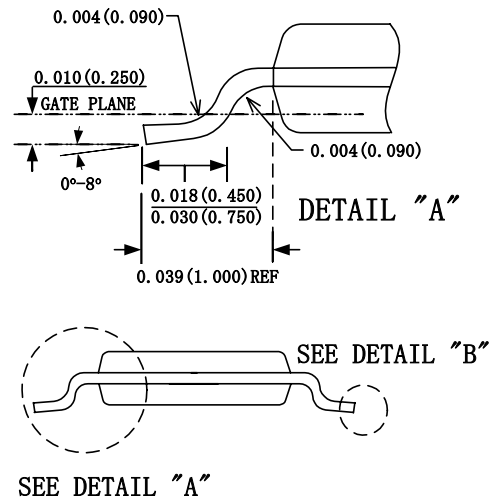
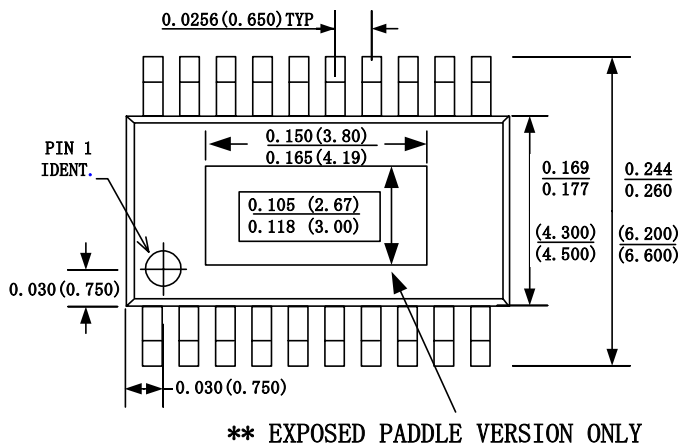

NOTE:

1) Control dimension is in inches. Dimension in bracket is millimeters.

NOTICE: MPS believes the information in this document to be accurate and reliable. However, it is subject to change without notice. Please contact the factory for current specifications. No responsibility is assumed by MPS for its use or fit to any application, nor for infringement of patent or other rights of third parties.