

RELEASED FOR PUBLICATION
LIBRE A LA DIFFUSION 20
ALL RIGHTS RESERVED.
TOUS DROITS RESERVES

© COPYRIGHT BY

LOC		DIST		REVISIONS			
P	LTR REV	DESCRIPTION MODIFICATIONS	DATE	DWN DESS.	APVD APP.		
	S3	REVISED PER ECR-14-014088	17NOV2014	NK	DC		

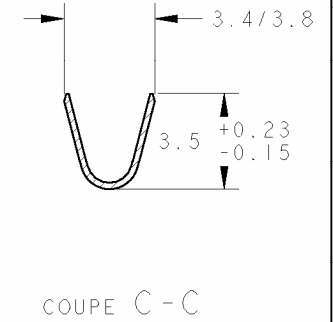
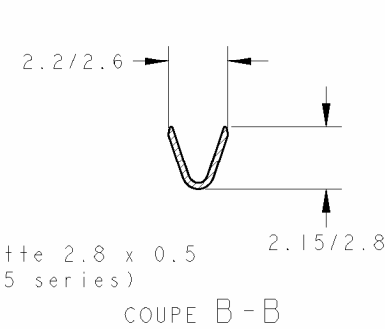
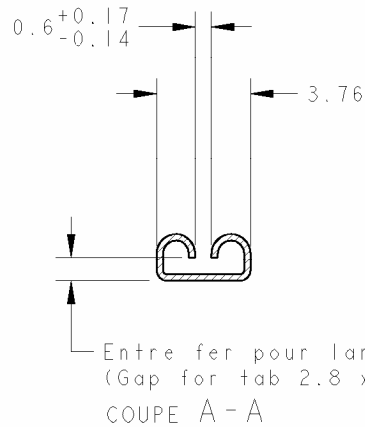
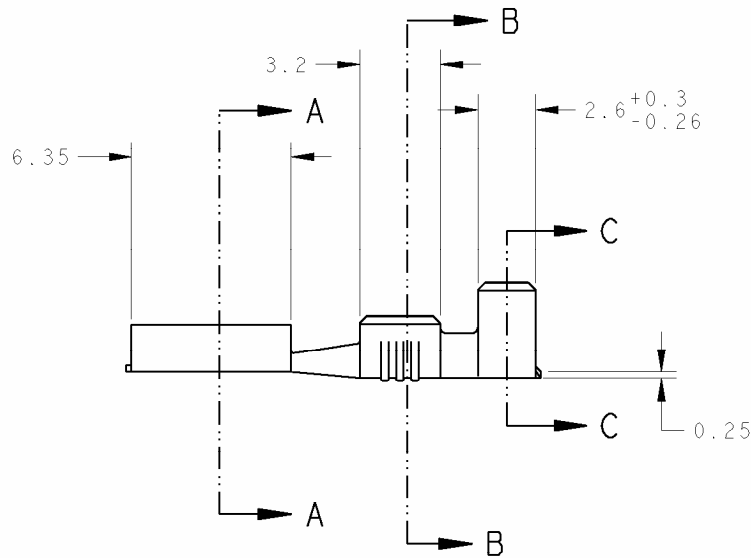

1 CONTINUOUS STRIP ON REEL: FEED 17.9±0.1
⚠ OBSOLETE.

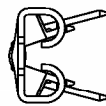
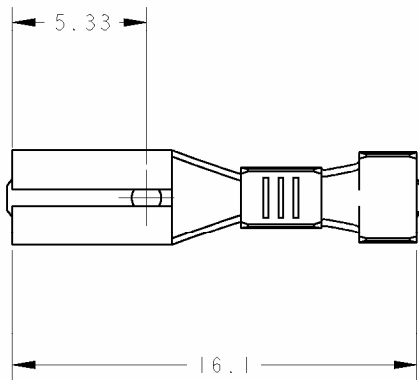

⚠	1.5 2.5	0.3 1	0.5	DORE	LAITON	141286-3	140719-3	140717-4
⚠	1.5 2.5	0.3 1	0.5	ARGENTE	LAITON	-	140719-4	140717-3
	1.5 2.5	0.3 1	0.5	PRE-ETAME	LAITON	141286-2	140719-2	140717-2
	1.5 2.5	0.3 1	0.5	BRUT	LAITON	141286-1	140719-1	140717-1
	DIA. ISOLANT	SECTION mm ²	Ep. TAB	FINITION	MATIERE	REFERENCE VRAC PREFORME	REFERENCE VRAC	REFERENCE

DIMENSIONS: mm		TOLERANCES UNLESS OTHERWISE SPECIFIED: TOLERANCES NON SPECIFIEES (SUIV NR. DE DECIMALES): 0 PLC /DEC: ± 1 PLC /DEC: ± 2 PLC /DEC: ±0.13 3 PLC /DEC: ± 4 PLC /DEC: ± ANGLES: ±		DWN/DESSINE 27MAR2001 C. COMBEDOUZON CHK/VERIFIE 02APR2001 V. FONDREVELLE APVD/APPROUVE 02APR2001 G. ROBERT		TE Connectivity	
MATERIAL /MATIERE v. table		FINISH /FINITION v. table		APPLICATION SPEC SPEC. APPLICATION 114-35000		NAME TITRE 110 SERIES FASTON RECEPTACLE	
WEIGHT MASSE APPROX. -		SIZE FORMAT A3		CAGE CODE 00779		DRAWING NO No PLAN C-140717	
CUSTOMER DRAWING /PLAN CLIENT				UNIQUEMENT POUR REFERENCE		SCALE ECHELLE 5:1	
		SHEET FEUILLE		OF DE		REV S3	