

3-Terminal Adjustable Positive Voltage Regulator

TO-220



TO-263 (D²PAK)



TO-252 (DPAK)



SOT-223



Pin Definition:

- 1. Adjustable
 - 2. Output
 - 3. Input
- Heatsink is connected to Pin 2

General Description

The TS317 is adjustable 3-terminal positive voltage regulator capable of supplying in excess of 1.5A over an output voltage range of 1.25 V to 37 V. This voltage regulator is exceptionally easy to use and require only two external resistors to set the output voltage. Further, it employs internal current limiting, thermal shutdown and safe area compensation, making it essentially blow-out proof.

Features

- Output Voltage Range 1.25 to 37V
- Output current
 - TO-220/TO-263 up to 1.5A
 - TO-252/SOT-223 up to 500mA
- Eliminates Stocking Many Fixed Voltages
- Internal Thermal Overload Protection
- Current Limit Constant with Temperature
- Output transistor safe-area compensation
- Output voltage offered in 4% tolerance
- Floating Operation for High Voltage Applications

Standard Application Circuit

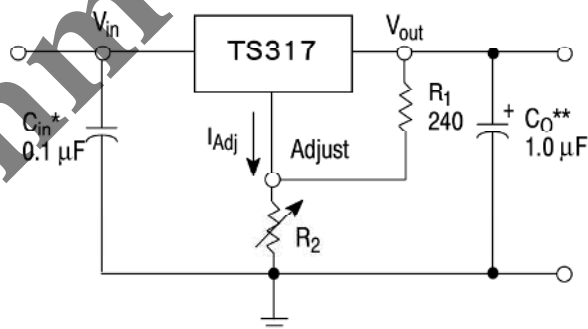

C_{in} is required if regulator is located an appreciable distance from power supply filter.

C_o is not needed for stability, however, it does improve transient response.

$$V_{out} = 1.25 V(1 + R_2 / R_1) + I_{Adj}R_2$$

Since I_{Adj} is controlled to less than 100 μA, the error associated with this term is negligible in most applications

Ordering Information

Part No.	Package	Packing
TS317CZ C0G	TO-220	50pcs / Tube
TS317CM RNG	TO-263	800pcs / 13" Reel
TS317CP ROG	TO-252	2.5Kpcs / 13" Reel
TS317CW RPG	SOT-223	2.5Kpcs / 13" Reel

Note: "G" denotes for Halogen Free

Absolute Maximum Rating (T_a = 25°C unless otherwise noted)

Parameter	Symbol	Limit	Unit
Input Voltage	V _{IN}	40	V
Power Dissipation	P _D	Internal Limited	W
Operating Junction Temperature	T _J	0~+125	°C
Storage Temperature Range	T _{STG}	-65~+150	°C

Thermal Performance

Condition	Package type	Symbol	Typ	Unit
Thermal Resistance Junction to Air	TO-220	$R\theta_{JA}$	50	°C/W
	TO-263		55	
	TO-252		100	
	SOT-223		130	
Thermal Resistance Junction to Case	TO-220	$R\theta_{JC}$	5	°C/W
	TO-263		5	
	TO-252		10	
	SOT-223		15	

Electrical Characteristics
 $(V_I - V_O = 5.0\text{ V}, I_o = 500\text{ mA for TO-220/TO-263 packages, } I_o = 200\text{ mA for TO-252/SOT-223 package})$

Parameter	Figure	Symbol	Min.	Typ.	Max.	Unit
Reference voltage, $3\text{ V} \leq V_I - V_O \leq 40\text{ V}$ $10\text{ mA} \leq I_o \leq I_{\text{max}}, P_d \leq P_{\text{max}}$	3	V_{ref}	1.20	1.25	1.30	V
Line regulation (Note 3) $T_a = 25^\circ\text{C}, 3\text{ V} \leq V_I - V_O \leq 40\text{ V}$	1	REG_{line}	--	0.01	0.07	%/V
Load regulation $T_a = 25^\circ\text{C}, 10\text{ mA} \leq I_o \leq I_{\text{max}}$ (Note 2) $V_O \leq 5.0$ $V_O \geq 5.0$	2	REG_{load}	--	5.0	25	mV
			--	0.1	0.5	%V
Thermal regulation, $T_a = 25^\circ\text{C}$ (Note 5), 20mS Pulse		$\text{REG}_{\text{therm}}$	--	0.03	0.07	%Vo/W
Adjustment pin current	3	I_{adj}	--	50	100	uA
Adjustment pin current change, $3\text{ V} \leq V_I - V_O \leq 40\text{ V}$ $10\text{ mA} \leq I_o \leq I_{\text{max}}, P_d \leq P_{\text{max}}$	1.2	ΔI_{adj}	--	0.2	5.0	uA
Maximum output current, $V_I - V_O \leq 15\text{ V}, P_d \leq P_{\text{max}}$ TO-220 / TO-263 Package TO-252 / SOT-223 Package	3	I_{max}	1.5	--	--	A
			0.5	--	--	
Temperature stability ($T_{\text{LOW}} \leq T_j \leq T_{\text{HIGH}}$)	3	T_s	--	1	--	% Vo
Minimum load current to maintain regulation ($V_I - V_O = 40\text{ V}$)	3	I_{Lmin}	--	3.5	10	mA
RMS Noise, % of V_O , $T_a = 25^\circ\text{C}, 10\text{ Hz} \leq f \leq 10\text{ KHz}$		N	--	0.003	--	% Vo
Ripple Rejection, $V_O = 10\text{ V}, f = 120\text{ Hz}$ (Note 3) Without C_{adj} $C_{\text{adj}} = 10\text{ uF}$	4	PSRR	--	65	--	dB
			66	80	--	
Long-term stability (Note 4), $T_j = 125^\circ\text{C}, 1000\text{ hrs}$	3	S	--	0.3	1.0	%

Notes: 1. T_{LOW} to $T_{\text{HIGH}} = 0^\circ\text{C}$ to $+125^\circ\text{C}$, P_{max} is internally limited

2. Load and line regulation are specified at constant junction temperature. Changes in V_O due to heating effects must be taken into account separately. Pulse testing with low duty cycle is used.

3. C_{adj} , when used, is connected between the adjustment pin and ground. Since Long-Term Stability cannot be measured on each device before shipment, this specification is an engineering estimate of average stability from lot to lot.

4. Power dissipation within an IC voltage regulator produces a temperature gradient on the die, affecting individual IC components on the die. These effects can be minimized by proper integrated circuit design and layout techniques. Thermal Regulation in the effect of these temperature gradients on the output voltage and is expressed in the percentage of output change per watt of power change in a specified time.

Functional Block Diagram

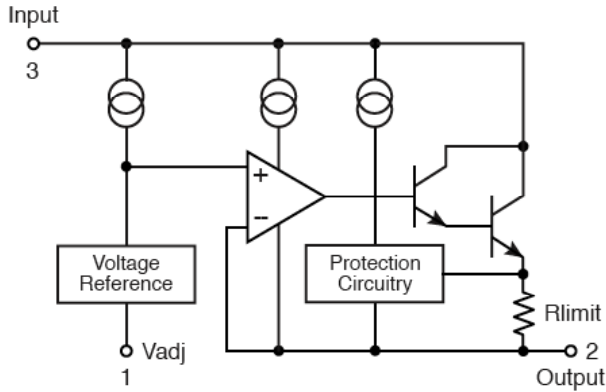

Test Circuit

Figure 1. Line Regulation Test Circuit

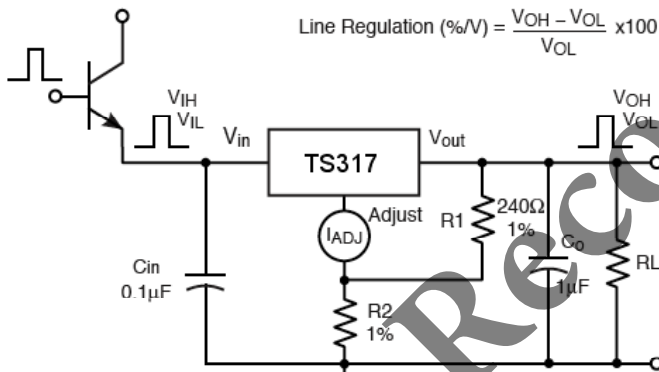

$$\text{Line Regulation (\%V)} = \frac{V_{OH} - V_{OL}}{V_{OL}} \times 100$$

Pulse Testing Required:
1% Duty Cycle is Suggested

Figure 3. Standard Test Circuit

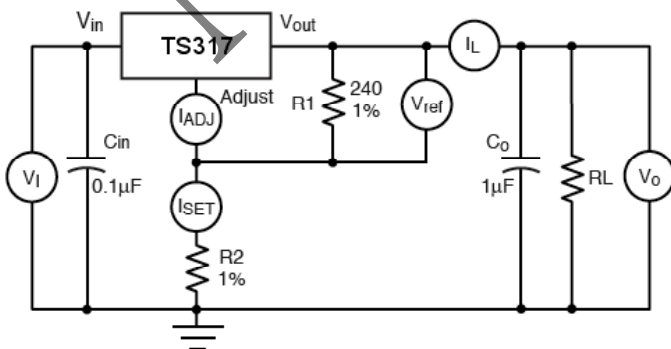

Pulse Testing Required:
1% Duty Cycle is Suggested

To Calculate R2:
 $V_O = I_{SET} R_2 + 1.25V$
Assume $I_{SET} = 5.25mA$

Figure 2. Load Regulation and $\Delta I_{adj}/Load$ Test Circuit

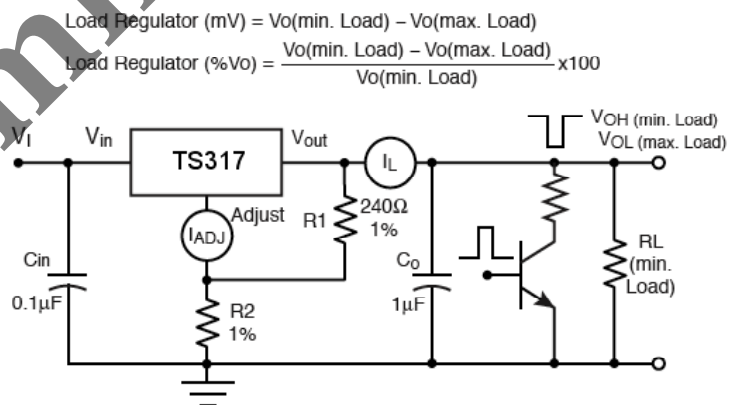

$$\text{Load Regulator (mV)} = V_{o(\text{min. Load})} - V_{o(\text{max. Load})}$$

$$\text{Load Regulator (\%V}_o) = \frac{V_{o(\text{min. Load})} - V_{o(\text{max. Load})}}{V_{o(\text{min. Load})}} \times 100$$

Pulse Testing Required:
1% Duty Cycle is Suggested

Figure 4. Ripple Rejection Test Circuit

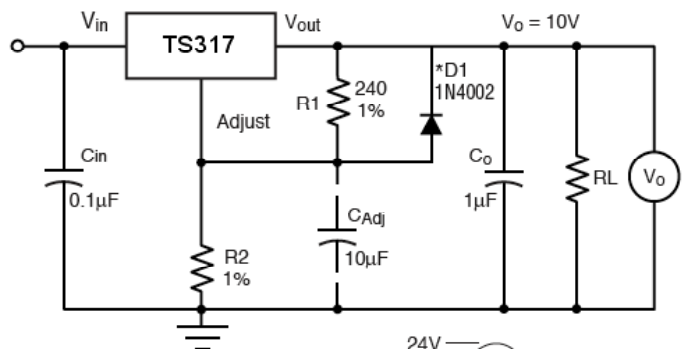

*D1 Discharges C_{ADJ} if Output is Shorted to Ground

24V
14V
f = 120Hz

Electrical Characteristics Curve

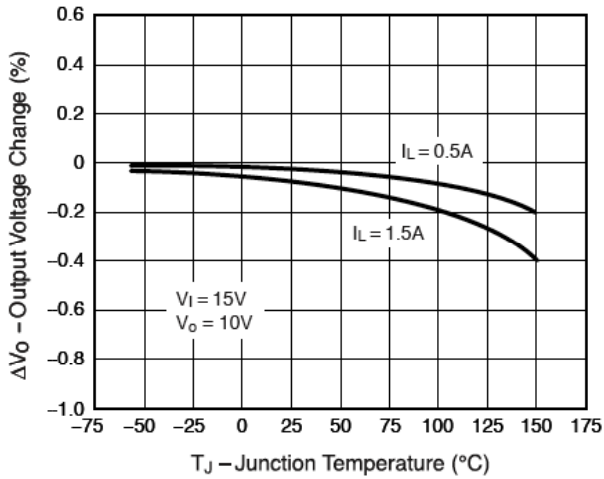

Figure 5. Load Regulation

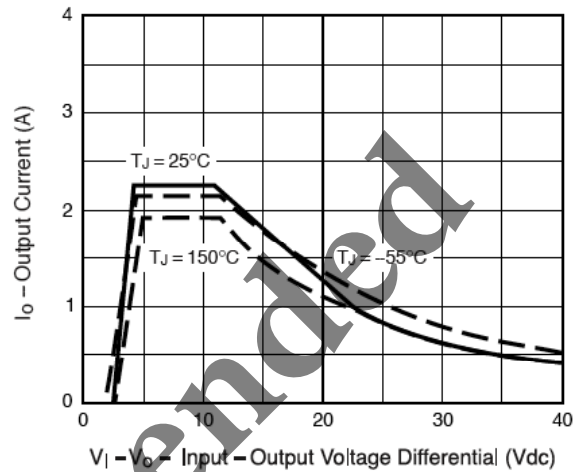

Figure 6. Current Limit

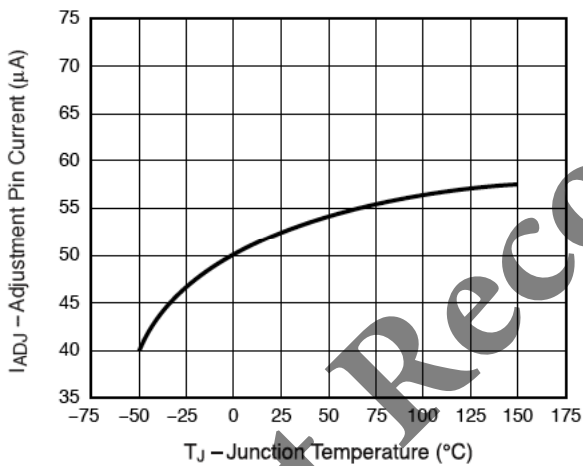

Figure 7. Adjustment Pin Current

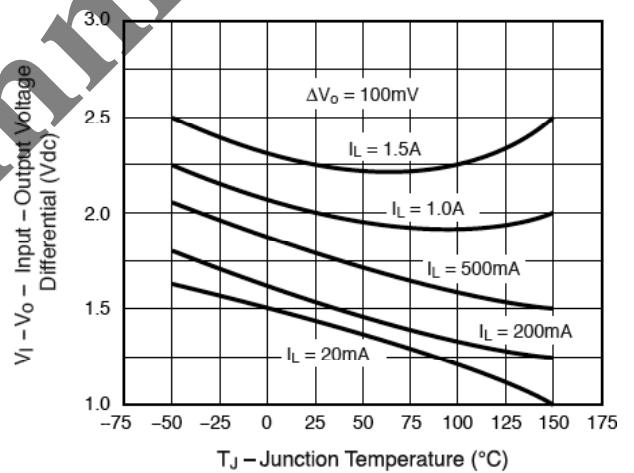

Figure 8. Dropout Voltage

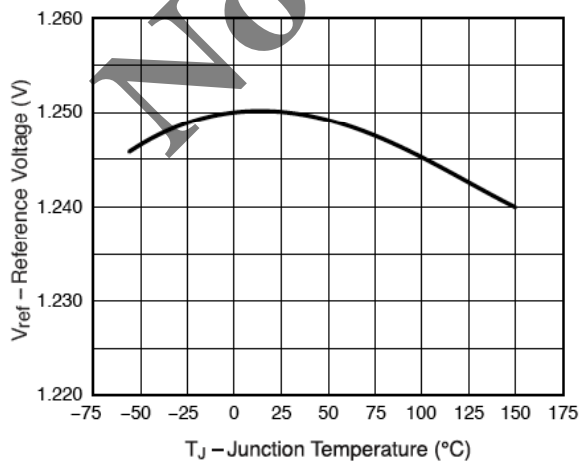

Figure 9. Temperature Stability

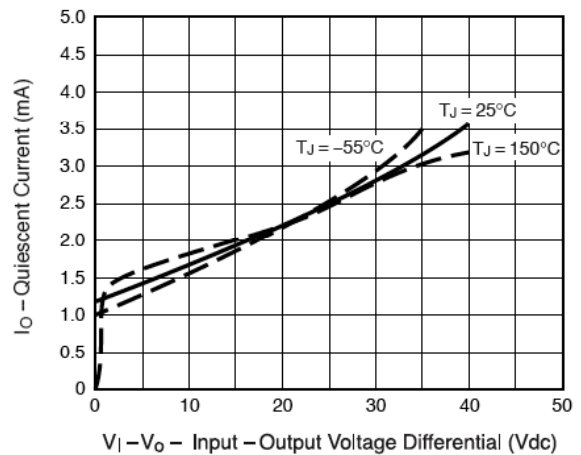

Figure 10. Minimum Operating Current

Electrical Characteristics Curve

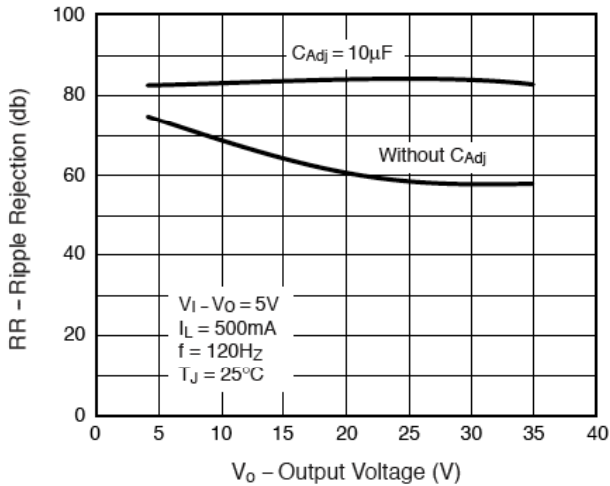

Figure 11. Ripple Rejection vs. Output Voltage

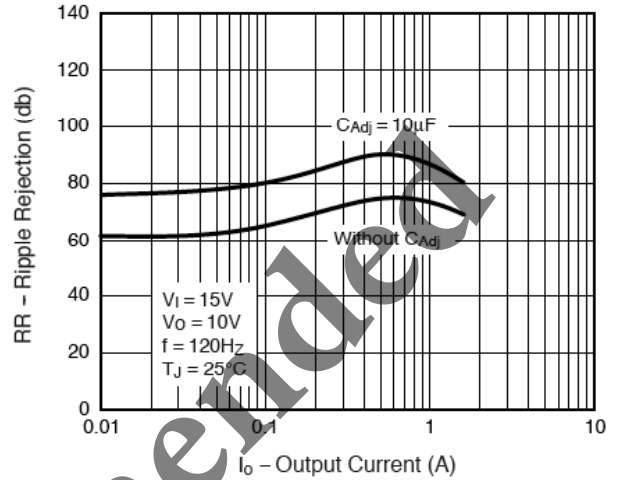

Figure 12. Ripple Rejection vs. Output Current

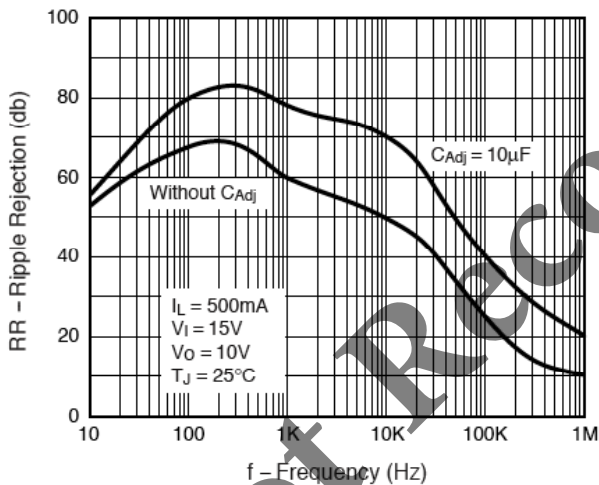

Figure 13. Ripple Rejection vs. Frequency

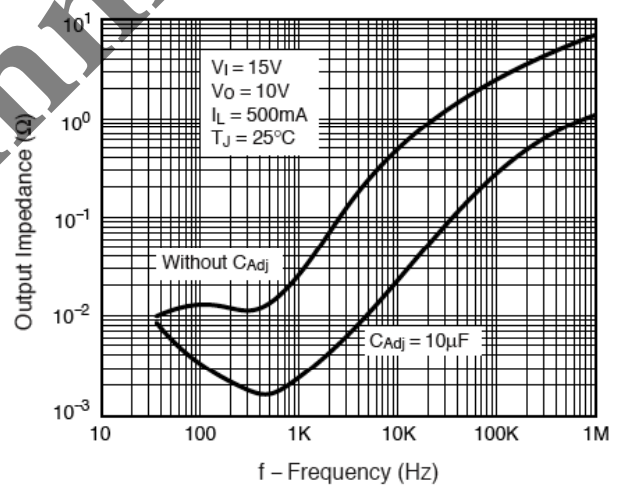

Figure 14. Output Impedance

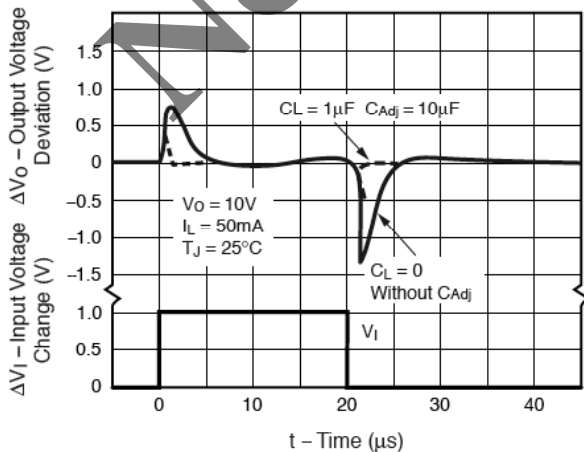

Figure 15. Line Transient Response

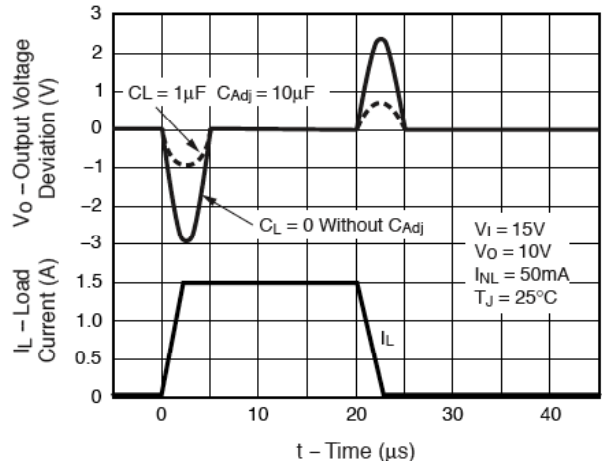

Figure 16. Load Transient Response

Application information

Basic Circuit Operation

The TS317 is a 3-terminal floating regulator. In operation, the TS317 develops and maintains a nominal 1.25V reference (V_{ref}) between its output and adjustment terminals. This reference voltage is converted to a programming current (I_{prog}) by R_1 (see Figure 17), and this constant current flows through R_2 to ground. The regulated output voltage is given by:

$$V_{out} = V_{ref} (1 + R_2 / R_1) + I_{adj} * R_2$$

Since the current from the adjustment terminal (I_{adj}) represents an error term in the equation, the TS317 was designed to control I_{adj} to less than 100uA and keep it constant. To do this, all quiescent operating current is returned to the output terminal. This imposes the requirement for a minimum load current. If the load current is less than this minimum, the output voltage will rise.

Since the TS317 is a floating regulator, it is only the voltage differential across the circuit which is important to performance, and operation at high voltages with respect to ground is possible.

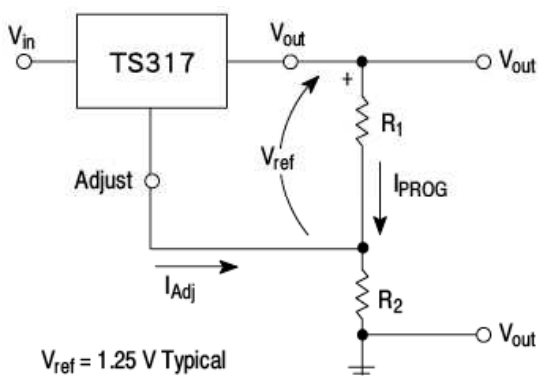

Figure 17. Basic Circuit Configuration

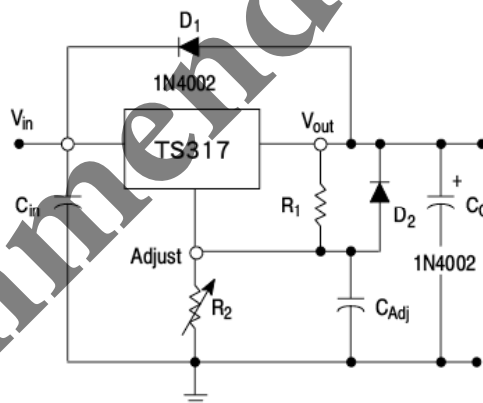

Figure 18. Voltage Regulator with Protection Diode

Protection Diode

When external capacitors are used with any I.C. regulator it is sometimes necessary to add protection diodes to prevent the capacitors from discharging through low current points into the regulator.

Figure 18 shows the TS317 with the recommended protection diodes for output voltages in excess of 25 V or high capacitance values ($C_o > 25\mu F$, $C_{adj} > 10\mu F$). Diode D_1 prevents C_o from discharging thru the I.C. during an input short circuit. Diode D_2 protects against capacitor C_{ADJ} discharging through the I.C. during an output short circuit. The combination of diodes D_1 and D_2 prevents C_{ADJ} from discharging through the I.C. during an input short circuit.

Load Regulation

The TS317 is capable of providing extremely good load regulation, but a few precautions are needed to obtain maximum performance. For best performance, the programming resistor (R_1) should be connected as close to the regulator as possible to minimize line drops which effectively appear in series with the reference, thereby degrading regulation. The ground end of R_2 can be returned near the load ground to provide remote ground sensing and improve load regulation.

External Capacitor

A 0.1 μF disc or 1 μF tantalum input bypass capacitor (C_{in}) is recommended to reduce the sensitivity to input line impedance. The adjustment terminal may be bypassed to ground to improve ripple rejection. This capacitor (C_{adj}) prevents ripple from being amplified as the output voltage is rejection about 15dB at 120 Hz in a 10V application. Although the TS317 is stable with no output capacitance, like any feedback circuit, certain values of external capacitance can cause excessive ringing. An output increased. A 10 μF capacitor should improve ripple capacitance (C_o) in the form of a 1 μF tantalum or 25 μF aluminum electrolytic capacitor on the output swamps this effect and insures stability.

Application information (Continue)

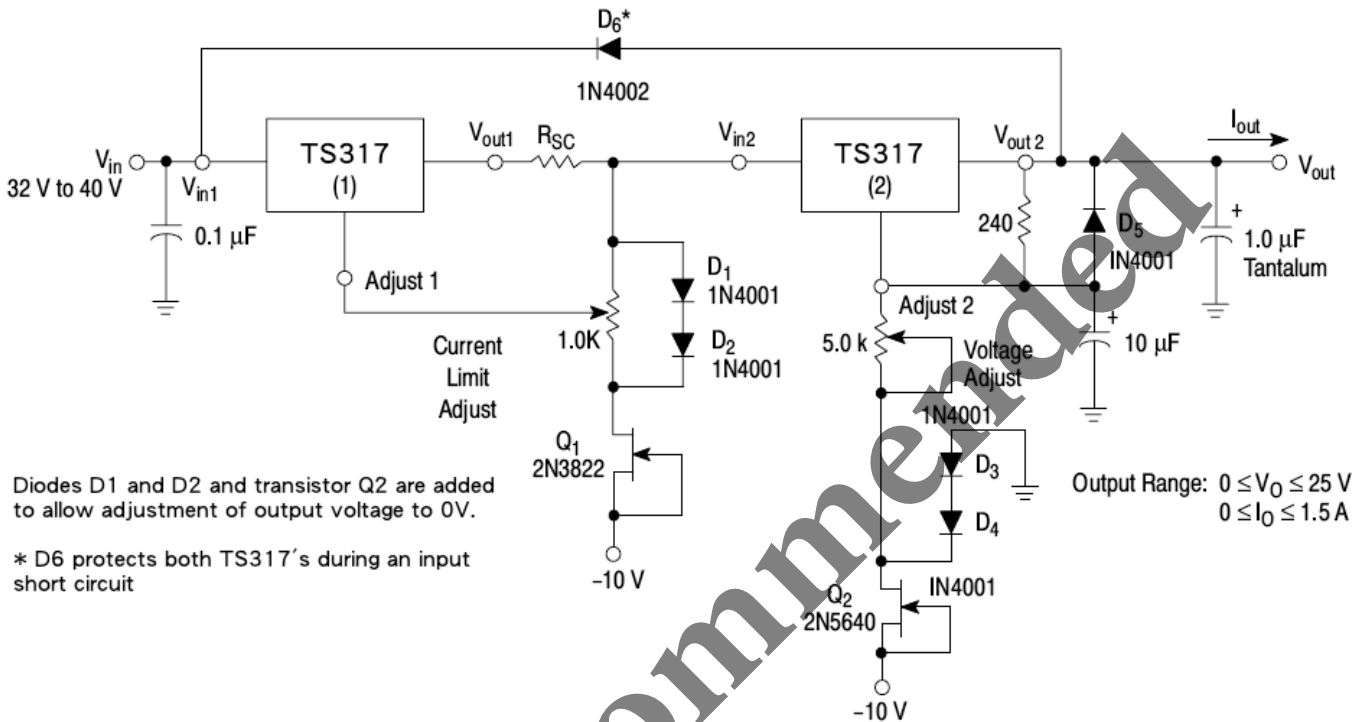

Figure 19. "LABORATORY" power supply with adjustable current limit and output voltage

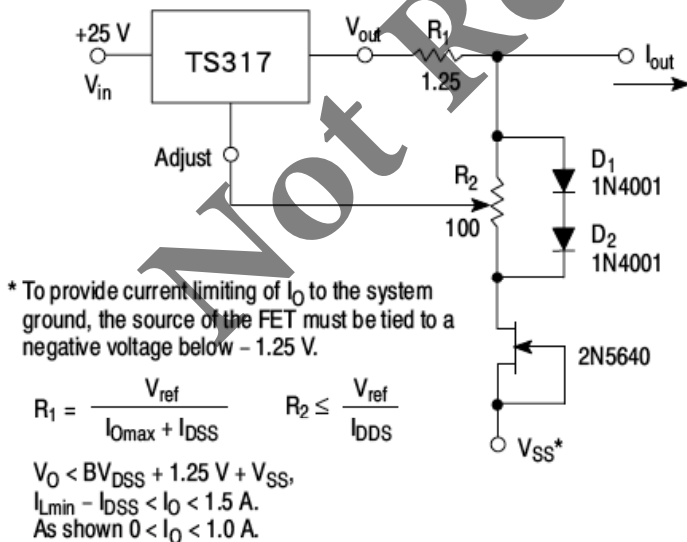

Figure 20. Adjustable Current Limiter

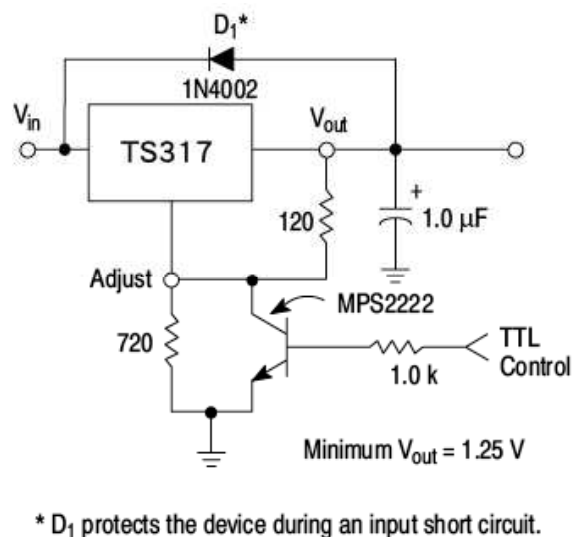

Figure 21. 5V Electronic Shutdown Regulator

Application information (Continue)

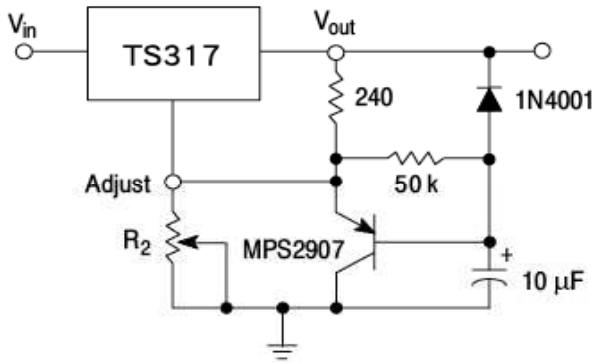

Figure 22. Slow Turn-on Regulator

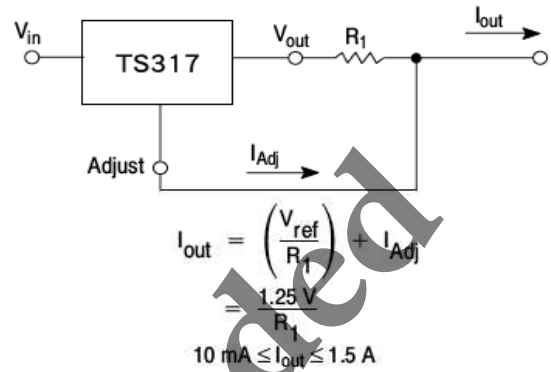

Figure 23. Current Regulator

Not Recommended

Application Information

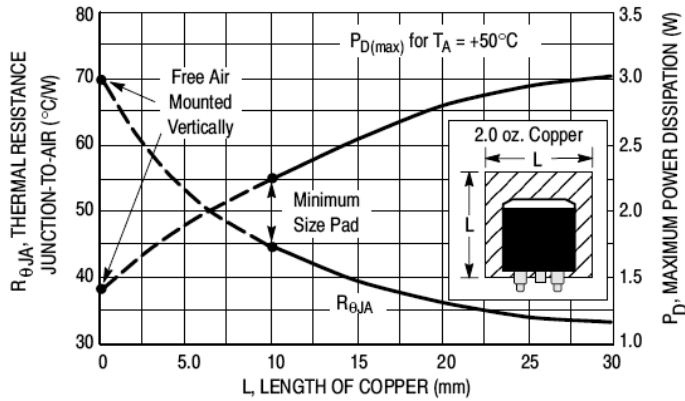

Figure 24. D²PAK Thermal Resistance and Maximum Power Dissipation vs. P.C.B Copper Length

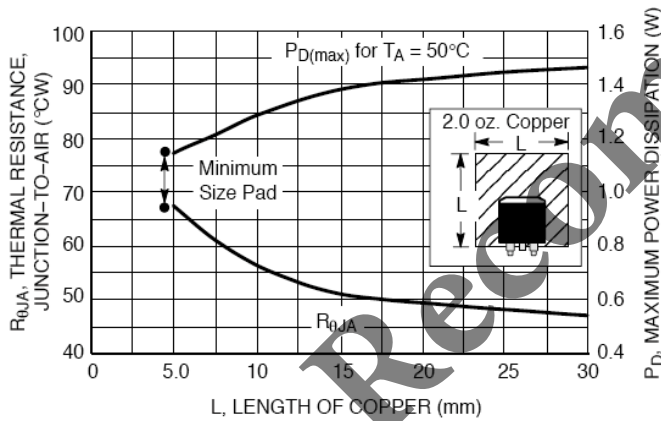

Figure 25. DPAK Thermal Resistance and Maximum Power Dissipation vs. P.C.B Copper Length

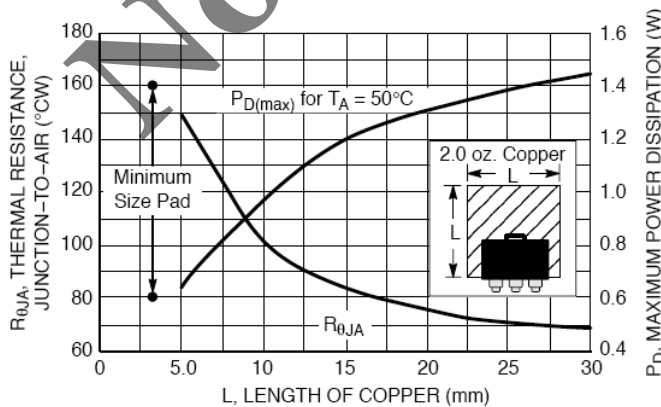
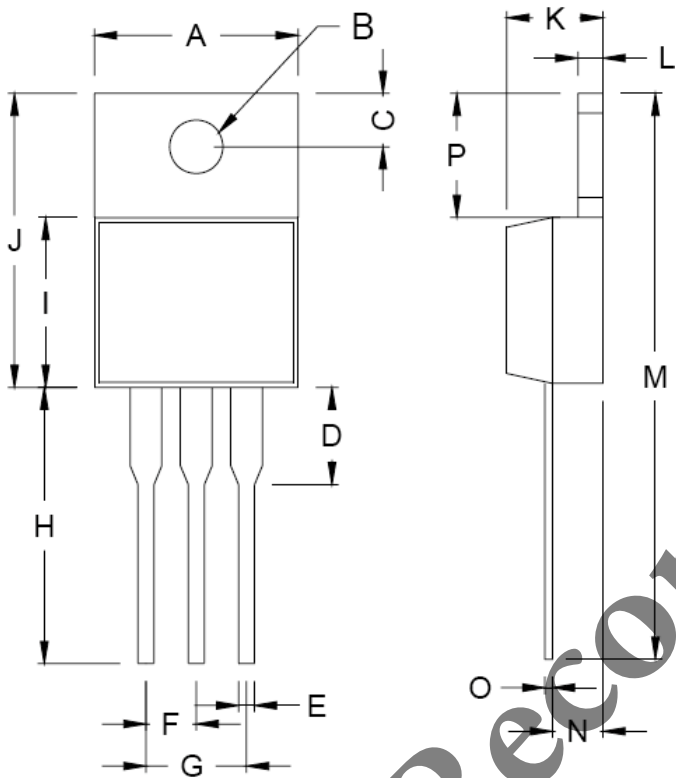

Figure 26. SOT-223 Thermal Resistance and Maximum Power Dissipation vs. P.C.B Copper Length

TO-220 Mechanical Drawing



DIM	MILLIMETERS		INCHES	
	MIN	MAX	MIN	MAX
A	10.000	10.500	0.394	0.413
B	3.740	3.910	0.147	0.154
C	2.440	2.940	0.096	0.116
D	-	6.350	-	0.250
E	0.381	1.106	0.015	0.040
F	2.345	2.715	0.092	0.058
G	4.690	5.430	0.092	0.107
H	12.700	14.732	0.500	0.581
I	8.382	9.017	0.330	0.355
J	14.224	16.510	0.560	0.650
K	3.556	4.826	0.140	0.190
L	0.508	1.397	0.020	0.055
M	27.700	29.620	1.060	1.230
N	2.032	2.921	0.080	0.115
O	0.255	0.610	0.010	0.024
P	5.842	6.858	0.230	0.270

Marking Diagram

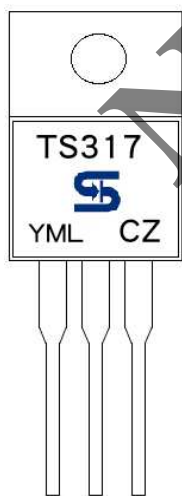

- Y = Year Code
- M = Month Code for Halogen Free Product
- O =Jan P =Feb Q =Mar R =Apr
- S =May T =Jun U =Jul V =Aug
- W =Sep X =Oct Y =Nov Z =Dec
- L = Lot Code
- CZ = Package Code for TO-220

TO-263 Mechanical Drawing

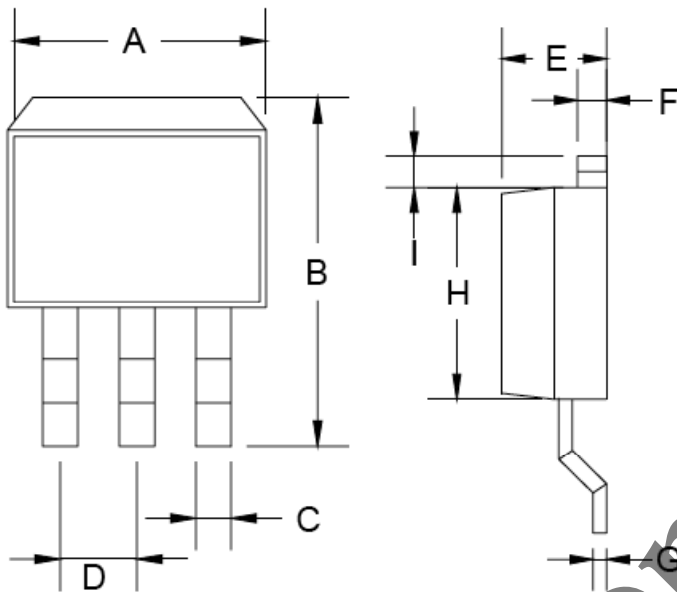

TO-263 DIMENSION				
DIM	MILLIMETERS		INCHES	
	MIN	MAX	MIN	MAX
A	10.000	10.500	0.394	0.413
B	14.605	15.875	0.575	0.625
C	0.508	0.991	0.020	0.039
D	2.420	2.660	0.095	0.105
E	4.064	4.830	0.160	0.190
F	1.118	1.400	0.045	0.055
G	0.450	0.730	0.018	0.029
H	8.280	8.800	0.325	0.346
I	1.140	1.400	0.044	0.055
J	1.480	1.520	0.058	0.060

Marking Diagram



- Y = Year Code
- M = Month Code for Halogen Free Product
 - O =Jan
 - P =Feb
 - Q =Mar
 - R =Apr
 - S =May
 - T =Jun
 - U =Jul
 - V =Aug
 - W =Sep
 - X =Oct
 - Y =Nov
 - Z =Dec
- L = Lot Code
- CM = Package Code for TO-263

TO-252 Mechanical Drawing

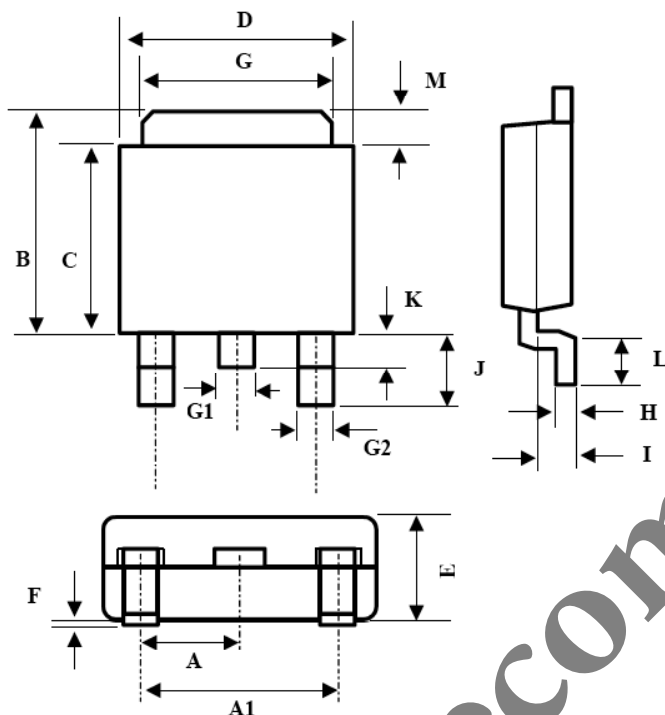

TO-252 DIMENSION				
DIM	MILLIMETERS		INCHES	
	MIN	MAX	MIN	MAX
A	2.3BSC		0.09BSC	
A1	4.6BSC		0.18BSC	
B	6.80	7.20	0.268	0.283
C	5.40	5.60	0.213	0.220
D	6.40	6.65	0.252	0.262
E	2.20	2.40	0.087	0.094
F	0.00	0.20	0.000	0.008
G	5.20	5.40	0.205	0.213
G1	0.75	0.85	0.030	0.033
G2	0.55	0.65	0.022	0.026
H	0.35	0.65	0.014	0.026
I	0.90	1.50	0.035	0.059
J	2.20	2.80	0.087	0.110
K	0.50	1.10	0.020	0.043
L	0.90	1.50	0.035	0.059
M	1.30	1.70	0.051	0.67

Marking Diagram

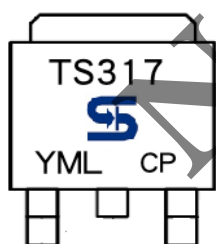

- Y = Year Code
- M = Month Code for Halogen Free Product
 - O =Jan
 - P =Feb
 - Q =Mar
 - R =Apr
 - S =May
 - T =Jun
 - U =Jul
 - V =Aug
 - W =Sep
 - X =Oct
 - Y =Nov
 - Z =Dec
- L = Lot Code
- CP = Package Code for TO-252

SOT-223 Mechanical Drawing

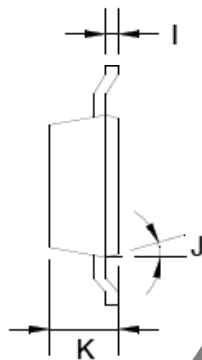
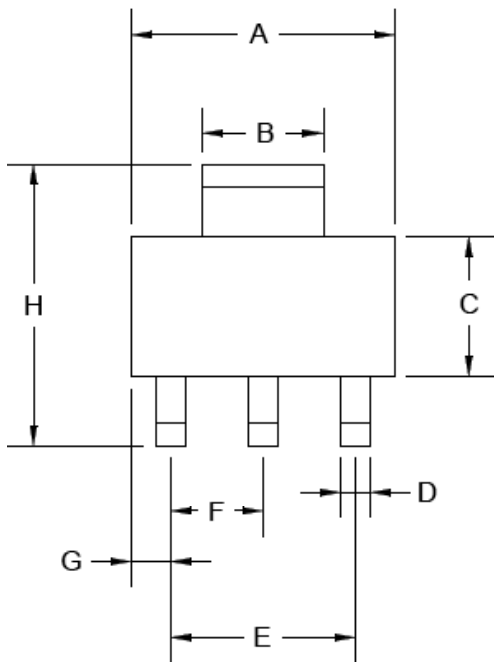

DIM	SOT-223 DIMENSION			
	MILLIMETERS		INCHES	
	MIN	MAX	MIN	MAX
A	6.350	6.850	0.250	0.270
B	2.900	3.100	0.114	0.122
C	3.300	3.750	0.129	0.148
D	0.660	0.840	0.025	0.033
E	4.550	4.650	0.179	0.183
F	2.250	2.350	0.088	0.093
G	0.850	1.050	0.033	0.041
H	6.700	7.300	0.263	0.287
I	0.230	0.355	0.009	0.014
J	10°	16°	10°	16°
K	1.550	1.800	0.061	0.071

Marking Diagram

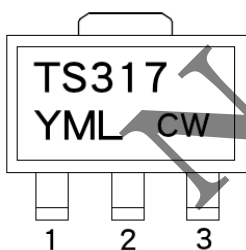

Y = Year Code
M = Month Code for Halogen Free Product
O =Jan **P** =Feb **Q** =Mar **R** =Apr
S =May **T** =Jun **U** =Jul **V** =Aug
W =Sep **X** =Oct **Y** =Nov **Z** =Dec
L = Lot Code
CW = Package Code for TO-223

Not Recommended

Notice

Specifications of the products displayed herein are subject to change without notice. TSC or anyone on its behalf, assumes no responsibility or liability for any errors or inaccuracies.

Information contained herein is intended to provide a product description only. No license, express or implied, to any intellectual property rights is granted by this document. Except as provided in TSC's terms and conditions of sale for such products, TSC assumes no liability whatsoever, and disclaims any express or implied warranty, relating to sale and/or use of TSC products including liability or warranties relating to fitness for a particular purpose, merchantability, or infringement of any patent, copyright, or other intellectual property right.

The products shown herein are not designed for use in medical, life-saving, or life-sustaining applications. Customers using or selling these products for use in such applications do so at their own risk and agree to fully indemnify TSC for any damages resulting from such improper use or sale.