

LOC		DIST		REVISIONS			
DF	DO	P	LTR	DESCRIPTION	DATE	DWN	APVO
		E		REVISED PER ECO-10-025541	24DEC10	SK	RL

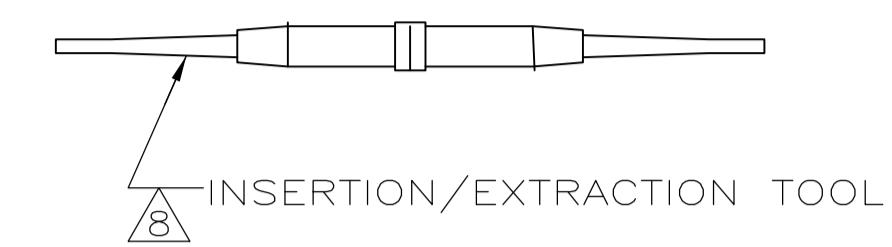

SOCKET CONTACT, SIZE 22, 26 REQD.
 BODY-MATL: BERYLLIUM COPPER PER QQ-C-530
 FINISH: PLATED GOLD .000050 MIN. THK.
 PER MIL-G-45204 OVER NICKEL .000050 MIN.
 THK. PER QQ-N-290
 HOOD-MAT'L: STAINLESS STEEL PER QQ-S-766
 FINISH: PASSIVATED PER QQ-P-35B

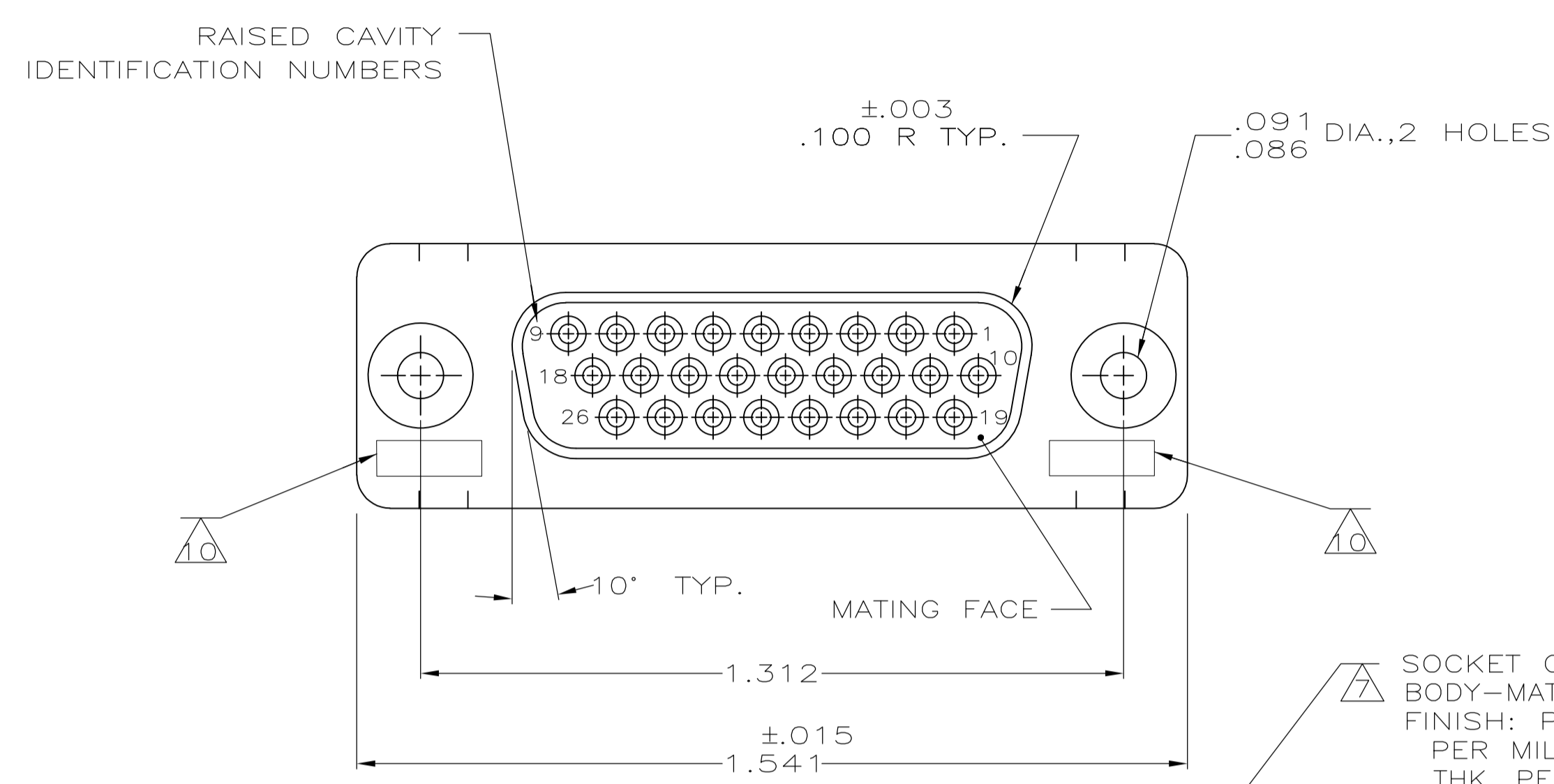
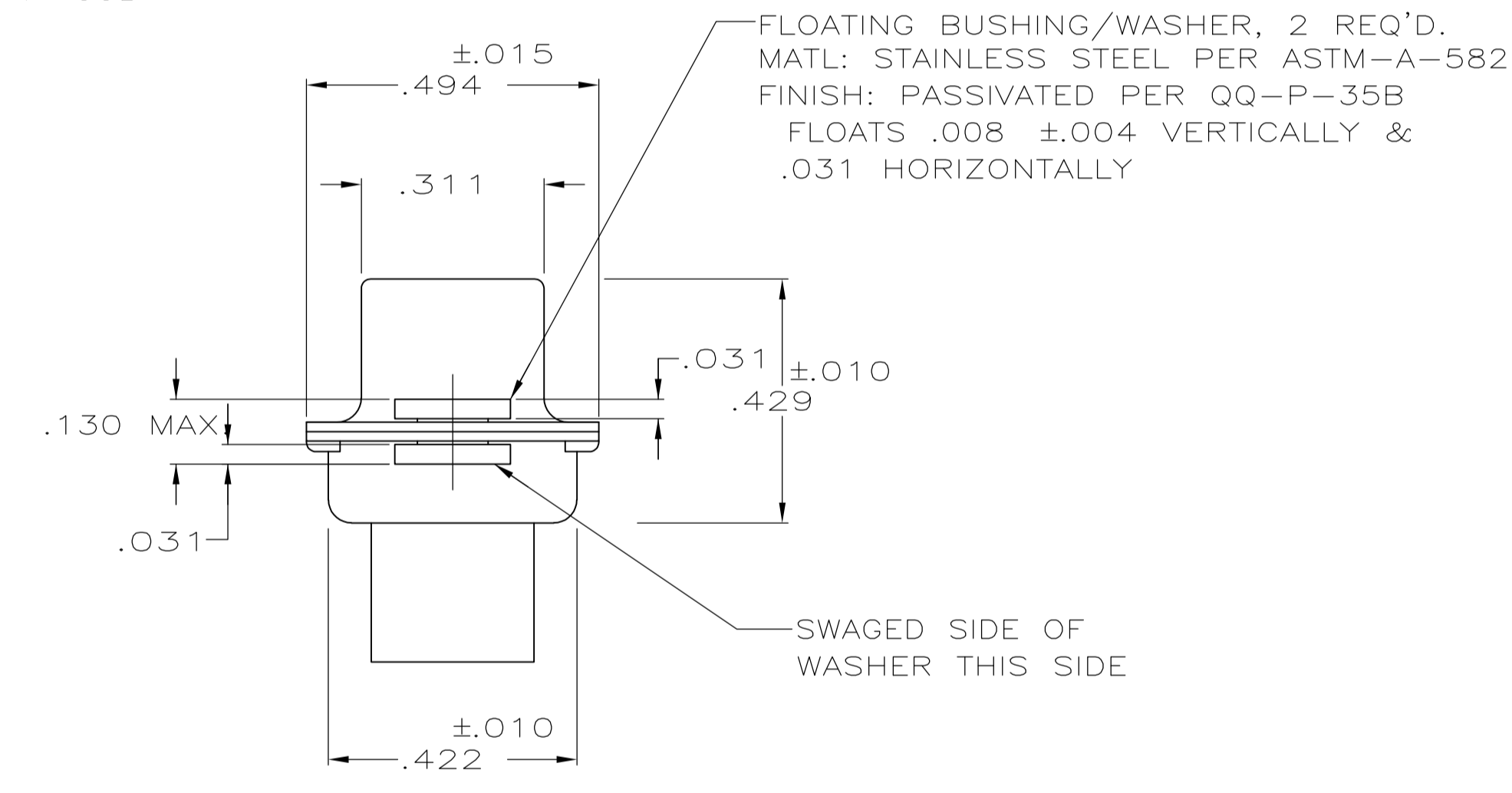
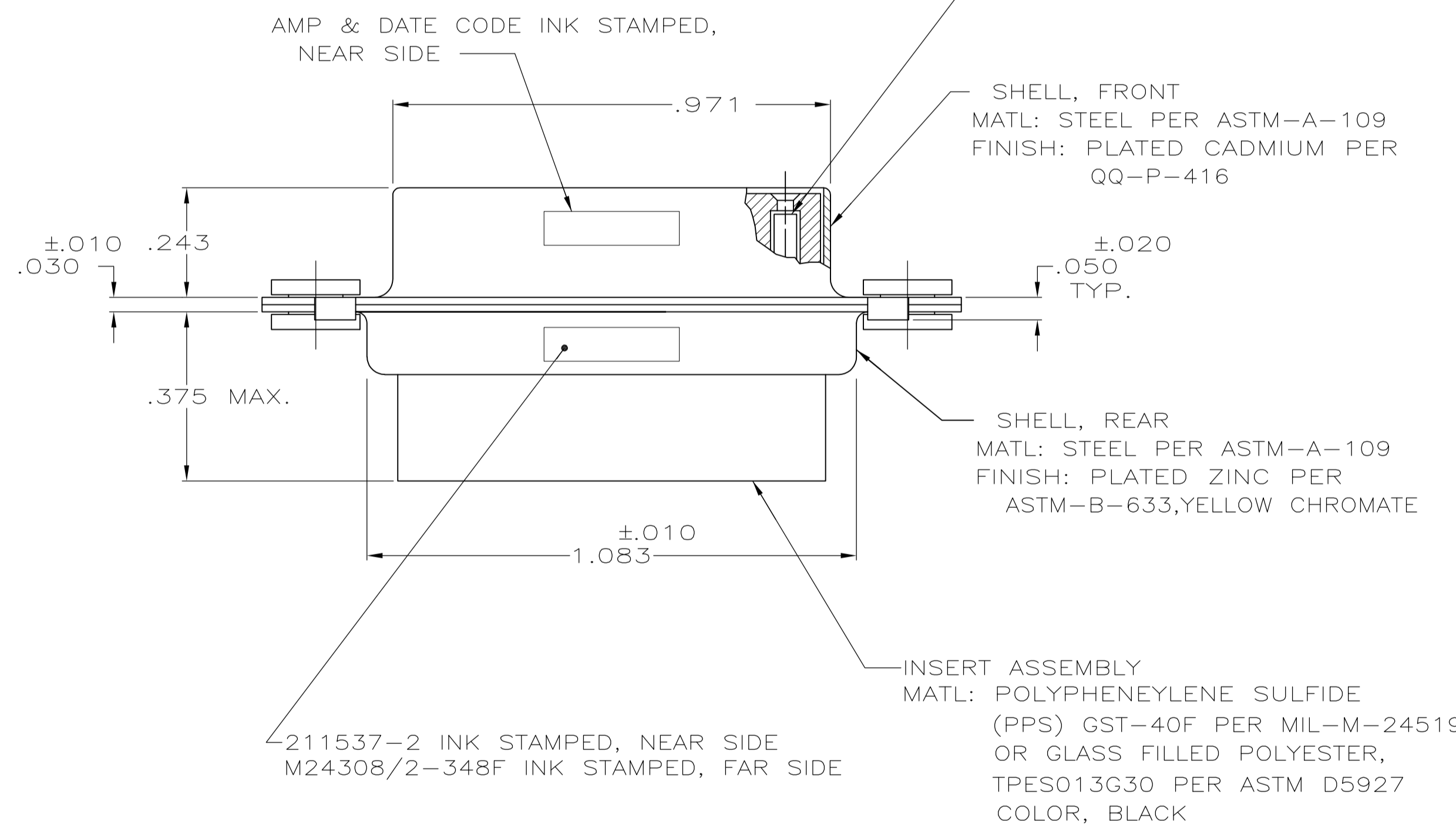

- THIS RECEPTACLE WILL MATE WITH ANY 26 POSN., SIZE 2 PLUG IN AMPLIMITE SERIES.
- MAXIMUM WIRE INSULATION TO BE USED WITH THIS RECEPTACLE IS .054 DIA.
- SST RETENTION CLIPS ARE INCLUDED IN INSERTS.

- ④ PACKAGE STAMPED M24308/2-488F & AMP P/N 211537-1
- ⑤ PACKAGE STAMPED M24308/2-348F & AMP P/N 211537-2
- ⑥ PACKAGE STAMPED M24308/2-359F & AMP P/N 211537-3
- ⑦ AMP P/N 204351-1; MIL P/N 57-354, INCLUDED IN KIT
- ⑧ AMP P/N 91067-1; MIL P/N M81969/1-04
- ⑨ CONNECTOR SUPPLIED WITHOUT CONTACTS; SHOWN FOR ILLUSTRATION ONLY.
- ⑩ UL/CSA DESIGNATION STAMPED IN THIS AREA.

SUPSD BY 204538-2 & 91067-1	SAME AS -1 EXCEPT: ⑥ ⑦ ⑧	211537-3
	SAME AS -1 EXCEPT: ⑤ ⑦	211537-2
	AS SHOWN	211537-1
	DESCRIPTION	PART NO

THIS DRAWING IS A CONTROLLED DOCUMENT.		DIN 7-1-85	Tyco Electronics Corporation	
DIMENSIONS: INCHES	TOLERANCES UNLESS OTHERWISE SPECIFIED:	DRW D ERDMAN 9-20-85	Harrisburg, PA 17105-3608	
0 PLC ± -	1 PLC ± -	CHK R GRZYBOWSKI	NAME	
2 PLC ± -	3 PLC ± .005	APVO G SACUNAS 9-20-85	Tyco Electronics	
4 PLC ± -	ANGLES ± -	PRODUCT SPEC	RECEPTACLE ASS'Y., AMPLIMITE, 26 POSN., SIZE 2, SERIES 90, W/DUAL FLOAT BUSHINGS	
MATERIAL SEE CALLOUT	FINISH SEE CALLOUT	APPLICATION SPEC	SIZE A1	RESTRICTED TO
		WEIGHT	CAGE CODE 00779	DRAWING NO 211537
		CUSTOMER DRAWING	SCALE NTS	SHEET 1 OF 1