

PART NO. ENG. NO.

02-06-1101	1561-(P901)
02-06-1103	1561-(P901)L
02-06-5101	1561-(P561)
02-06-5102	1561-(P561)L
02-06-5108	1561-(P228)
02-06-5109	1561-(P228)L
02-06-5100	1561-(P550)
02-06-5103	1561-(P550)L
02-06-5105	1561-(P591)
02-06-5104	1561-(P591)L
02-06-1118	1561-1(P901)
NOT TOOLED	1561-1(P901)L

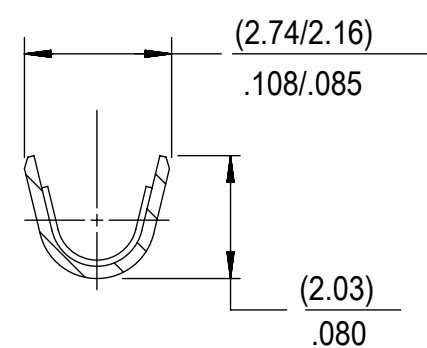

SECT. "B-B"

SCALE:10X

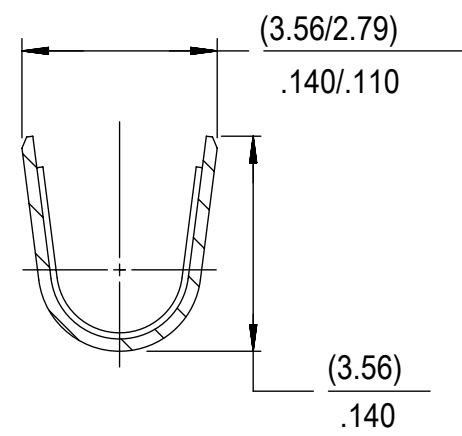

SECT. "C-C"

SCALE:10X

LEGEND

1561-*(****)*

BLANK=WITH LOCKING TABS
1=WITHOUT LOCKING TABS

FORM
BLANK=CHAIN
L=LOOSE

P=PREPLATE
BLANK=POSTPLATE

FINISH CODE

NOTES:

- MATERIAL: BRASS
- FINISH:
 - 901 HOT TIN DIP (.00051)/.000020 MIN.
 - 228 SELECT GOLD PLATE (.00075)/.000030 MIN. IN CONTACT AREA, SELECT TIN. (.00250)/.000100 MIN. IN CRIMP AREA OVER (.00125)/.000050 MIN. NICKEL OVERALL.
 - 561 SELECT GOLD PLATE (.00076)/.000030 MIN. IN CONTACT AREA, OVER (.00127)/.000050 MIN. NICKEL OVERALL.
 - 591 SELECT GOLD PLATE (.00175)/.000050 MIN. IN CONTACT AREA, OVER (.00127)/.000050 MIN. NICKEL OVERALL WITH (.000025)/.000010 MAX. GOLD FLASH OVERALL.
 - 550 SELECT GOLD PLATE (.00038)/.000015 MIN. IN CONTACT AREA, OVER (.00076)/.000030 MIN. NICKEL OVERALL WITH (.000025)/.000010 MAX. GOLD FLASH OVERALL.
- PRODUCT SPECIFICATION: PS-02-06.
- PACKAGING INFORMATION:
 - LOOSE TERMINALS: PK-1190-003
 - CHAIN TERMINALS: 15610000-PK
- TERMINAL FOR USE WITH (1.57)/.062 DIA. SERIES HOUSINGS AND WILL ACCEPT 18 THRU 24 AWG WIRE WITH (1.52/3.05)/.060/.120 INSULATION DIA.
- PARTS CONFORM TO CLASS B REQUIREMENTS OF COSMETIC SPECIFICATION PS-45499-002.
- TIP GEOMETRY IS TOOL DEPENDENT. EITHER GEOMETRY IS ACCEPTABLE.

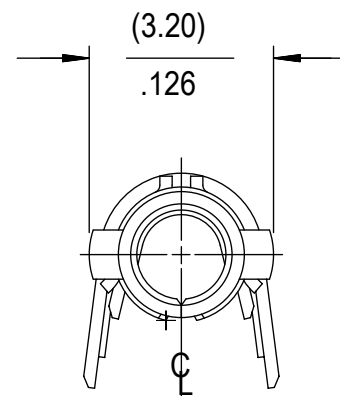

(.25) MAX.
.010
CARRIER CUTOFF

"A"

(16.8)
.66

GAP ACCEPTABLE
SEE ALTERNATE
TIP VIEW

OPTIONAL LOCKING TAB
(2 PL.) SEE LEGEND

"B"

"B"

"C"

"C"

"A"

(.25) MAX.
.010
CARRIER CUTOFF

(1.50/1.42)
.059/.056

DIA.

(2.03)
.080

(1.52)
.060

SELECT GOLD
PLATE DEPTH
(WHEN SPECIFIED)

(.38)
.015

SECT. "A-A"

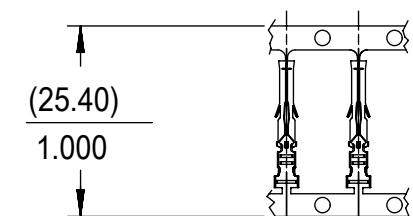
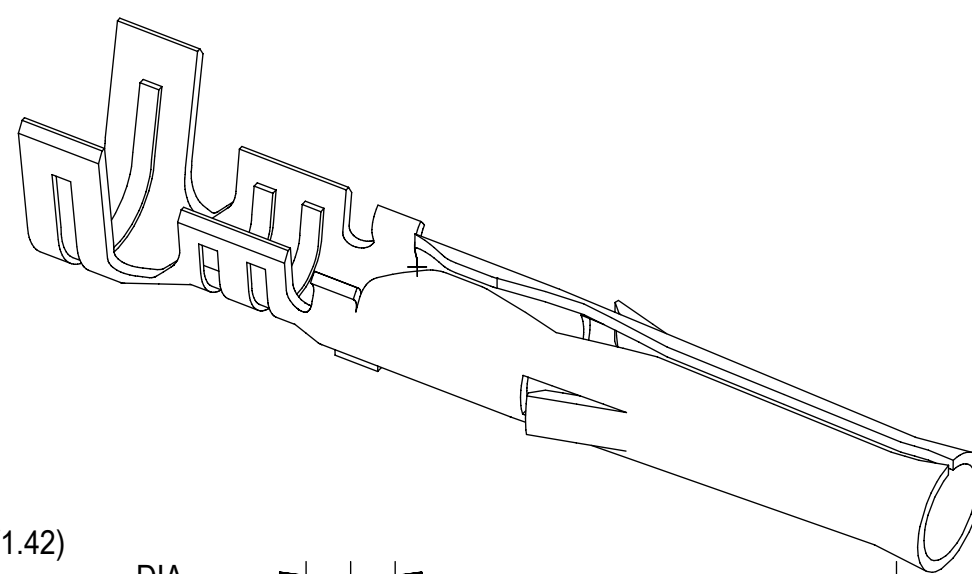

CARRIER VIEW
ACTUAL SIZE

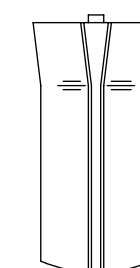

ALTERNATE TIP GEOMETRY
SEE NOTE 7

THIS DRAWING CONTAINS INFORMATION THAT IS PROPRIETARY TO MOLEX ELECTRONIC TECHNOLOGIES, LLC AND SHOULD NOT BE USED WITHOUT WRITTEN PERMISSION													
SYMBOLS		DIMENSION UNITS		SCALE		CURRENT REV DESC: UPDATE PK SPEC							
▽ = 0	▽ = 0	MM/IN		NTS		EC NO: 614240 DRWN: JEHRISMAN 2019/03/22 CHK'D: FSMITH 2019/05/10 APPR: FSMITH 2019/05/10 INITIAL REVISION: DRWN: GEW 1991/02/19 APPR: GWF 1991/02/19							
▽ = 0	▽ = 0	GENERAL TOLERANCES (UNLESS SPECIFIED)											
▽ = 0	▽ = 0	4 PLACES ±		MM								INCH	
▽ = 0	▽ = 0	3 PLACES ±		± 0.01									
▽ = 0	▽ = 0	2 PLACES ±		± 0.25		± 0.014							
▽ = 0	▽ = 0	1 PLACE ±		± 0.36		±							
▽ = 0	▽ = 0	0 PLACES ±		±		±							
▽ = 0	▽ = 0	ANGULAR TOL ± 0.5 °		THIRD ANGLE PROJECTION		DRAWING		SERIES		MATERIAL NUMBER			
▽ = 0	▽ = 0	DRAFT WHERE APPLICABLE MUST REMAIN WITHIN DIMENSIONS		C-SIZE		1561		SEE TABLE		CUSTOMER			
								GENERAL MARKET		SHEET NUMBER			
								1 OF 1					

molex

CRIMP TERMINAL, FEMALE
.062 DIA. FOR 18-24 AWG WIRE

PRODUCT CUSTOMER DRAWING

DOCUMENT NUMBER DOC TYPE DOC PART REVISION

SD-1561-X PSD 001 AP3

MATERIAL NUMBER CUSTOMER SHEET NUMBER

SEE TABLE GENERAL MARKET 1 OF 1