

# HFBR-53D5 Family, 850 nm VCSEL HFCT-53D5 Family, 1300 nm FP Laser

## 1 x 9 Fiber Optic Transceivers for Gigabit Ethernet



## Data Sheet

### Description

The HFBR/HFCT-53D5 transceiver from Avago Technologies allows the system designer to implement a range of solutions for multimode and single mode Gigabit Ethernet applications.

The overall Avago Technologies transceiver product consists of three sections: the transmitter and receiver optical subassemblies, an electrical subassembly, and the package housing which incorporates a duplex SC connector receptacle.

### Transmitter Section

The transmitter section of the HFBR-53D5 consists of an 850 nm Vertical Cavity Surface Emitting Laser (VCSEL) in an optical subassembly (OSA), which mates to the fiber cable. The HFCT-53D5 incorporates a 1300 nm Fabry-Perot (FP) Laser designed to meet the Gigabit Ethernet LX specification. The OSA is driven by a custom, silicon bipolar IC which converts differential PECL logic signals (ECL referenced to a +5 Volt supply) into an analog laser diode drive current.

### Receiver Section

The receiver of the HFBR-53D5 includes a silicon PIN photodiode mounted together with a custom, silicon bipolar transimpedance preamplifier IC in an OSA. This OSA is mated to a custom silicon bipolar circuit that provides post-amplification and quantization. The HFCT-53D5 utilizes an InP PIN photodiode in the same configuration. The post-amplifier also includes a Signal Detect circuit which provides a PECL logic-high output upon detection of a usable input optical signal level. This single-ended PECL output is designed to drive a standard PECL input through a 50  $\Omega$  PECL load.

### Features

- Compliant with Specifications for IEEE- 802.3z Gigabit Ethernet
- Industry Standard Mezzanine Height 1 x 9 Package Style with Integral Duplex SC Connector
- Performance
  - HFBR-53D5:
    - 220 m with 62.5/125 mm MMF
    - 500 m with 50/125 mm MMF
  - HFCT-53D5:
    - 550 m with 62.5/125 mm MMF
    - 550 m with 50/125 mm MMF
    - 10 km with 9/125 SMF
- IEC 60825-1 Class 1/CDRH Class I Laser Eye Safe
- Single +5 V Power Supply Operation with PECL Logic Interfaces
- Wave Solder and Aqueous Wash Process Compatible

### Related Products

- Physical Layer ICs Available for Optical or Copper Interface (HDMP-1636A/1646A)
- Versions of this Transceiver Module Also Available for Fibre Channel (HFBR/HFCT-53D3)
- Gigabit Interface Converters (GBIC) for Gigabit Ethernet (CX, SX, LX)

### Applications

- Switch to Switch Interface
- Switched Backbone Applications
- High Speed Interface for File Servers
- High Performance Desktops

## Package and Handling Instructions

### Flammability

The HFBR/HFCT-53D5 transceiver housing is made of high strength, heat resistant, chemically resistant, and UL 94V-0 flame retardant plastic.

### Recommended Solder and Wash Process

The HFBR/HFCT-53D5 is compatible with industry standard wave or hand solder processes.

### Process plug

This transceiver is supplied with a process plug (HFBR-5000) for protection of the optical ports within the duplex SC connector receptacle. This process plug prevents contamination during wave solder and aqueous rinse as well as during handling, shipping and storage. It is made of a high-temperature, molded sealing material that can withstand 80° C and a rinse pressure of 110 lbs per square inch.

Recommended Solder fluxes Solder fluxes used with the HFBR/HFCT-53D5 should be water-soluble, organic fluxes. Recommended solder fluxes include Lonco 3355-11 from London Chemical West, Inc. of Burbank, CA, and 100 Flux from Alpha-Metals of Jersey City, NJ.

### Recommended Cleaning/Degreasing Chemicals

*Alcohols:* methyl, isopropyl, isobutyl.

*Aliphatics:* hexane, heptane

*Other:* soap solution, naphtha.

*Do not use* partially halogenated hydrocarbons such as 1,1,1 trichloroethane, ketones such as MEK, acetone, chloroform, ethyl acetate, methylene dichloride, phenol, methylene chloride, or N-methylpyrrolidone. Also, HP does not recommend the use of cleaners that use halogenated hydrocarbons because of their potential environmental harm.

### Regulatory Compliance

(See the Regulatory Compliance Table for transceiver performance)

The overall equipment design will determine the certification level. The transceiver performance is offered as a figure of merit to assist the designer in considering their use in equipment designs.

## Electrostatic Discharge (ESD)

There are two design cases in which immunity to ESD damage is important. The first case is during handling of the transceiver prior to mounting it on the circuit board. It is important to use normal ESD handling precautions for ESD sensitive devices. These precautions include using grounded wrist straps, work benches, and floor mats in ESD controlled areas. The transceiver performance has been shown to provide adequate performance in typical industry production environments.

The second case to consider is static discharges to the exterior of the equipment chassis containing the transceiver parts. To the extent that the duplex SC connector receptacle is exposed to the outside of the equipment chassis it may be subject to whatever system-level ESD test criteria that the equipment is intended to meet. The transceiver performance is more robust than typical industry equipment requirements of today.

## Electromagnetic Interference (EMI)

Most equipment designs utilizing these high-speed transceivers from Avago Technologies will be required to meet the requirements of FCC in the United States, CENELEC EN55022 (CISPR 22) in Europe and VCCI in Japan. Refer to EMI section (page 5) for more details.

## Immunity

Equipment utilizing these transceivers will be subject to radio-frequency electromagnetic fields in some environments. These transceivers have good immunity to such fields due to their shielded design.

## Eye Safety

These laser-based transceivers are classified as AEL Class I (U.S. 21 CFR(J) and AEL Class 1 per EN 60825-1 (+A11)). They are eye safe when used within the data sheet limits per CDRH. They are also eye safe under normal operating conditions and under all reasonably foreseeable single fault conditions per EN60825-1. Avago Technologies has tested the transceiver design for compliance with the requirements listed below under normal operating conditions and under single fault conditions where applicable. TÜV Rheinland has granted certification to these transceivers for laser eye safety and use in EN 60950 and EN 60825-2 applications. Their performance enables the transceivers to be used without concern for eye safety up to 7 volts transmitter VCC.

## CAUTION:

There are no user serviceable parts nor any maintenance required for the HFBR/HFCT-53D5. All adjustments are made at the factory before shipment to our customers. Tampering with or modifying the performance of the HFBR/HFCT-53D5 will result in voided product warranty. It may also result in improper operation of the HFBR/HFCT-53D5 circuitry, and possible overstress of the laser source. Device degradation or product failure may result.

Connection of the HFBR/HFCT- 53D5 to a nonapproved optical source, operating above the recommended absolute maximum conditions or operating the HFBR/HFCT-53D5 in a manner inconsistent with its design and function may result in hazardous radiation exposure and may be considered an act of modifying or manufacturing a laser product. The person(s) performing such an act is required by law to recertify and reidentify the laser product under the provisions of U.S. 21 CFR (Subchapter J).

## APPLICATION SUPPORT

### Optical Power Budget and Link Penalties

The worst-case Optical Power Budget (OPB) in dB for a fiberoptic link is determined by the difference between the minimum transmitter output optical power (dBm avg) and the lowest receiver sensitivity (dBm avg). This OPB provides the necessary optical signal range to establish a working fiber-optic link. The OPB is allocated for the fiber-optic cable length and the corresponding link penalties. For proper link performance, all penalties that affect the link performance must be accounted for within the link optical power budget. The Gigabit Ethernet IEEE 802.3z standard identifies, and has modeled, the contributions of these OPB penalties to establish the link length requirements for 62.5/125 mm and 50/125 mm multimode fiber usage. In addition, single-mode fiber with standard 1300 nm Fabry-Perot lasers have been modeled and specified. Refer to the IEEE 802.3z standard and its supplemental documents that develop the model, empirical results and final specifications.

## Regulatory Compliance

Feature	Test Method	Performance
Electrostatic Discharge (ESD) to the Electrical Pins	MIL-STD-883C Method 3015.4	Class 1 (> 2000 V).
Electrostatic Discharge (ESD) to the Duplex SC Receptacle	Variation of IEC 801-2	Typically withstand at least 15 kV without damage when the duplex SC connector receptacle is contacted by a Human Body Model probe.
Electromagnetic Interference (EMI)	FCC Class B CENELEC EN55022 Class B (CISPR 22A) VCCI Class I	Margins are dependent on customer board and chassis designs.
Immunity	Variation of IEC 801-3	Typically show no measurable effect from a 10 V/m field swept from 27 to 1000 MHz applied to the transceiver without a chassis enclosure.
Laser Eye Safety and Equipment Type Testing	US 21 CFR, Subchapter J per Paragraphs 1002.10 and 1002.12  EN 60825-1: 1994 +A11 EN 60825-2: 1994 EN 60950: 1992 + A1 + A2 + A3	AEL Class I, FDA/CDRH HFBR-53D5 Accension #9720151-03  AEL Class 1, TUV Rheinland of North America HFBR-53D5 Certificate #9771018.5 Protection Class III
Component Recognition	Underwriters Laboratories and Canadian Standards Association Joint Component Recognition for Information Technology Equipment Including Electrical Business Equipment.	UL File E173874 (Pending)

## 10 km Link Support

As well as complying with the LX 5 km standard, the HFCT-53D5 specification provides additional margin allowing for a 10 km Gigabit Ethernet link on single mode fiber. This is accomplished by limiting the spectral width and center wavelength range of the transmitter while increasing the output optical power and improving sensitivity. All other LX cable plant recommendations should be followed.

### Data Line Interconnections

Avago Technologies' HFBR/ HFCT-53D5 fiber-optic transceiver is designed to directly couple to +5 V PECL signals. The transmitter inputs are internally DC-coupled to the laser driver circuit from the transmitter input pins (pins 7, 8). There is no internal, capacitively-coupled 50 Ohm termination resistance within the transmitter input section. The transmitter driver circuit for the laser light source is a DC-coupled circuit. This circuit regulates the output optical power. The regulated light output will maintain a constant output optical power provided the data pattern is reasonably balanced in duty factor. If the data duty factor has long, continuous state times (low or high data duty factor), then the output optical power will gradually change its average output optical power level to its pre-set value. As for the receiver section, it is internally AC-coupled between the pre-amplifier and the post-amplifier stages. The actual Data and Data-bar outputs of the postamplifier are DC-coupled to their respective output pins (pins 2, 3). Signal Detect is a single-ended, +5 V PECL output signal that is DC-coupled to pin 4 of the module. Signal Detect should not be AC-coupled externally to the follow-on circuits because of its infrequent state changes. Caution should be taken to account for the proper interconnection between the supporting Physical Layer integrated circuits and this HFBR/HFCT-53D5 transceiver. Figure 3 illustrates a recommended interface circuit for interconnecting to a +5 Vdc PECL fiber-optic transceiver.

Some fiber-optic transceiver suppliers' modules include internal capacitors, with or without 50 Ohm termination, to couple their Data and Data-bar lines to the I/O pins of their module. When designing to use these type of transceivers along with Avago Technologies transceivers, it is

important that the interface circuit can accommodate either internal or external capacitive coupling with 50 Ohm termination components for proper operation of both transceiver designs. The internal DC-coupled design of the HFBR/HFCT-53D5 I/O connections was done to provide the designer with the most flexibility for interfacing to various types of circuits.

### Eye Safety Circuit

For an optical transmitter device to be eye-safe in the event of a single fault failure, the transmitter must either maintain normal, eye-safe operation or be disabled. In the HFBR-53D5 there are three key elements to the laser driver safety circuitry: a monitor diode, a window detector circuit, and direct control of the laser bias. The window detection circuit monitors the average optical power using the monitor diode. If a fault occurs such that the transmitter DC regulation circuit cannot maintain the preset bias conditions for the laser emitter within  $\pm 20\%$ , the transmitter will automatically be disabled. Once this has occurred, only an electrical power reset will allow an attempted turn-on of the transmitter.

The HFCT-53D5 utilizes an integral fiber stub along with a current limiting circuit to guarantee eye-safety. It is intrinsically eye safe and does not require shut down circuitry.

### Signal Detect

The Signal Detect circuit provides a deasserted output signal that implies the link is open or the transmitter is OFF as defined by the Gigabit Ethernet specification IEEE 802.3z, Table 38.1. The Signal Detect threshold is set to transition from a high to low state between the minimum receiver input optional power and -30 dBm avg. input optical power indicating a definite optical fault (e.g. unplugged connector for the receiver or transmitter, broken fiber, or failed far-end transmitter or data source). A Signal Detect indicating a working link is functional when receiving encoded 8B/10B characters. The Signal Detect does not detect receiver data error or error-rate. Data errors are determined by Signal processing following the transceiver.

## Electromagnetic Interference (EMI)

One of a circuit board designer's foremost concerns is the control of electromagnetic emissions from electronic equipment. Success in controlling generated Electromagnetic Interference (EMI) enables the designer to pass a governmental agency's EMI regulatory standard; and more importantly, it reduces the possibility of interference to neighboring equipment. There are three options available for the HFBR-53D5 and two options for the HFCT-53D5 with regard to EMI shielding which provide the designer with a means to achieve good EMI performance. The EMI performance of an enclosure using these transceivers is dependent on the chassis design. Avago Technologies encourages using standard RF suppression practices and avoiding poorly EMI-sealed enclosures.

The first configuration is a standard HFBR-53D5 fiber-optic transceiver that has no external EMI shield. This unit is for applications where EMI is either not an issue for the designer, or the unit resides completely inside a shielded enclosure, or the module is used in low density, extremely quiet applications. The HFCT-53D5 is not available for use without an external shield.

The second configuration, option EM, is for EMI shielding applications where the position of the transceiver module will extend outside the equipment enclosure. The metallized plastic package and integral external metal shield of the transceiver helps locally to terminate EM fields to the chassis to prevent their emissions outside the enclosure. This metal shield contacts the panel or enclosure on the inside of the aperture on all but the bottom side of the shield and provides a good RF connection to the panel. This option can accommodate various panel or enclosure thickness, i.e., 0.04 in. min. to 0.10 in. max. The reference plane for this panel thickness variation is from the front surface of the panel or enclosure. The recommended length for protruding the HFBR/HFCT-53D5EM transceiver beyond the front surface of the panel or enclosure is 0.25 in. With this option, there is flexibility of positioning the module to fit the specific need of the enclosure design. (See Figure 6 for the mechanical drawing dimensions of this shield.)

The third configuration, option FM, is for applications that are designed to have a flush mounting of the module with respect to the front of the panel or enclosure. The flush-mount design accommodates a large variety of panel thickness, i.e., 0.04 in. min. to 0.10 in. max. Note the reference plane for the flush-mount design is the interior side of the panel or enclosure. The recommended distance from the centerline of the transceiver front solder posts to the inside wall of the panel is 0.55 in. This option contacts the inside panel or enclosure wall on all four sides of this metal shield. See Figure 8 for the mechanical drawing dimensions of this shield.

The two metallized designs are comparable in their shielding effectiveness. Both design options connect only to the equipment chassis and not to the signal or logic ground of the circuit board within the equipment closure. The front panel aperture dimensions are recommended in Figures 7 and 9. When layout of the printed circuit board is done to incorporate these metal-shielded transceivers, keep the area on the printed circuit board directly under the metal shield free of any components and circuit board traces. For additional EMI performance advantage, use duplex SC fiber-optic connectors that have low metal content inside them. This lowers the ability of the metal fiber-optic connectors to couple EMI out through the aperture of the panel or enclosure.

### Evaluation Kit

To help you in your preliminary transceiver evaluation, Avago Technologies offers a 1250 MBd Gigabit Ethernet evaluation board (Part # HFBR-0535). This board allows testing of the fiber-optic VCSEL transceiver. It includes the HFBR-53D5 transceiver, test board, and application instructions. For single mode transceiver evaluation the HFCT-53D5 can be substituted on this evaluation board. In addition, a complementary evaluation board is available for the HDMP-1636A 1250 MBd Gigabit Ethernet serializer/deserializer (SERDES) IC. (Part # HDMP-163k) Please contact your local Field Sales representative for ordering details.

## Absolute Maximum Ratings

Parameter	Symbol	Min.	Typ.	Max.	Unit	Reference
Storage Temperature	T <sub>S</sub>	-40		100	°C	
Supply Voltage	V <sub>CC</sub>	-0.5		7.0	V	1
Data Input Voltage	V <sub>I</sub>	-0.5		V <sub>CC</sub>	V	
Transmitter Differential Input Voltage	V			1.6	V	2
Output Current	I <sub>D</sub>			50	mA	
Relative Humidity	RH	5		95	%	

## Recommended Operating Conditions

Parameter	Symbol	Min.	Typ.	Max.	Unit	Reference
Input Optical Power	P <sub>IN</sub>	-17		0	dBm avg.	7
Stressed Receiver Sensitivity	62.5 μm			-12.5	dBm avg.	8
	50 μm			-13.5	dBm avg.	8
Stressed Receiver Eye Opening at TP4		201			ps	6,9
Receiver Electrical 3 dB Upper Cutoff Frequency				1500	MHz	10
Operating Center Wavelength	λ <sub>C</sub>	770		860	nm	
Return Loss		12			dB	11
Signal Detect – Asserted	P <sub>A</sub>			-18	dBm avg.	
Signal Detect – Deasserted	P <sub>D</sub>	-30			dBm avg.	
Signal Detect – Hysteresis	P <sub>A</sub> - P <sub>D</sub>	1.5			dB	

## Process Compatibility

Parameter	Symbol	Min.	Typ.	Max.	Unit	Reference
Hand Lead Soldering Temperature /Time	T <sub>SOLD</sub> /t <sub>SOLD</sub>			260/10	°C/sec.	
Wave Soldering and Aqueous Wash	T <sub>SOLD</sub> /t <sub>SOLD</sub>			260/10	°C/sec.	7

### Notes:

1. The transceiver is class 1 eye-safe up to V<sub>CC</sub> = 7 V.
2. This is the maximum voltage that can be applied across the Differential Transmitter Data Inputs without damaging the input circuit.
3. Case temperature measurement referenced to the center-top of the internal metal transmitter shield.
4. Tested with a 50 mV<sub>p-p</sub> sinusoidal signal in the frequency range from 500 Hz to 1500 kHz on the V<sub>CC</sub> supply with the recommended power supply filter in place. Typically less than a 0.25 dB change in sensitivity is experienced.
5. Compatible with 10 K, 10 KH, and 100 K ECL and PECL input signals.
6. The outputs are terminated to V<sub>CC</sub> -2 V.
7. Aqueous wash pressure < 110 psi.

## HFBR-53D5 Family, 850 nm VCSEL

### Transmitter Electrical Characteristics

( $T_A = 0^\circ\text{C}$  to  $+70^\circ\text{C}$ ,  $V_{CC} = 4.75\text{ V}$  to  $5.25\text{ V}$ )

Parameter	Symbol	Min.	Typ.	Max.	Unit	Reference
Supply Current	$I_{CCT}$		85	120	mA	
Power Dissipation	$P_{DIST}$		0.45	0.63	W	
Data Input Current – Low	$I_{IL}$	-350	0		$\mu\text{A}$	
Data Input Current – High	$I_{IH}$		16	350	$\mu\text{A}$	
Laser Reset Voltage	$V_{CCT-reset}$		2.7	2.5	V	1

### Receiver Electrical Characteristics

( $T_A = 0^\circ\text{C}$  to  $+70^\circ\text{C}$ ,  $V_{CC} = 4.75\text{ V}$  to  $5.25\text{ V}$ )

Parameter	Symbol	Min.	Typ.	Max.	Unit	Reference
Supply Current	$I_{CCR}$		105	130	mA	
Power Dissipation	$P_{DISR}$		0.53	0.63	W	2
Data Output Voltage – Low	$V_{OL} - V_{CC}$	-1.950		-1.620	V	3
Data Output Voltage – High	$V_{OH} - V_{CC}$	-1.045		-0.740	V	3
Data Output Rise Time	$t_T$			0.40	ns	4
Data Output Fall Time	$t_f$			0.40	ns	4
Signal Detect Output Voltage – Low	$V_{OL} - V_{CC}$	-1.950		-1.620	V	3
Signal Detect Output Voltage – High	$V_{OH} - V_{CC}$	-1.045		-0.740	V	3

#### Notes:

1. The Laser Reset Voltage is the voltage level below which the  $V_{CCT}$  voltage must be lowered to cause the laser driver circuit to reset from an electrical/optical shutdown condition to a proper electrical/optical operating condition. The maximum value corresponds to the worst-case highest  $V_{CC}$  voltage necessary to cause a reset condition to occur. The laser safety shutdown circuit will operate properly with transmitter  $V_{CC}$  levels of 3.5 Vdc  $\leq V_{CC} \leq 7.0$  Vdc.
2. Power dissipation value is the power dissipated in the receiver itself. It is calculated as the sum of the products of  $V_{CC}$  and  $I_{CC}$  minus the sum of the products of the output voltages and currents.
3. These outputs are compatible with 10 K, 10 KH, and 100 K ECL and PECL inputs.
4. These are 20-80% values.

## HFBR-53D5 Family, 850 nm VCSEL

### Transmitter Optical Characteristics

( $T_A = 0^\circ\text{C}$  to  $+70^\circ\text{C}$ ,  $V_{CC} = 4.75\text{ V}$  to  $5.25\text{ V}$ )

Parameter	Symbol	Min.	Typ.	Max.	Unit	Reference
Output Optical Power 50/125 mm, NA = 0.20 Fiber	$P_{OUT}$	-95		-4	dBm avg.	1
Output Optical Power 62.5/125 mm, NA = 0.275 Fiber	$P_{OUT}$	-95		-4	dBm avg.	1
Optical Extinction Ratio		9			dB	2
Center Wavelength	$\lambda_C$	830	850	860	nm	
Spectral Width – rms	$\sigma$			0.85	nm rms	
Optical Rise / Fall Time	$t_r/t_f$			0.26	ns	3, 4, Fig. 1
$RIN_{12}$				-117	dB/Hz	
Coupled Power Ratio	CPR	9			dB	5
Total Transmitter Jitter Added at TP2				227	ps	6

### Receiver Optical Characteristics

( $T_A = 0^\circ\text{C}$  to  $+70^\circ\text{C}$ ,  $V_{CC} = 4.75\text{ V}$  to  $5.25\text{ V}$ )

Parameter	Symbol	Min.	Typ.	Max.	Unit	Reference
Input Optical Power	$P_{IN}$	-17		0	dBm avg.	7
Stressed Receiver Sensitivity	62.5 $\mu\text{m}$			-12.5	dBm avg.	8
	50 $\mu\text{m}$			-13.5	dBm avg.	8
Stressed Receiver Eye Opening at TP4		201			ps	6,9
Receiver Electrical 3 dB Upper Cutoff Frequency				1500	MHz	10
Operating Center Wavelength	$\lambda_C$	770		860	nm	
Return Loss		12			dB	11
Signal Detect – Asserted	$P_A$			-18	dBm avg.	
Signal Detect – Deasserted	$P_D$	-30			dBm avg.	
Signal Detect – Hysteresis	$P_A - P_D$	1.5			dB	

#### Notes:

- The maximum Optical Output Power complies with the IEEE 802.3z specification, and is class 1 laser eye safe.
- Optical Extinction Ratio is defined as the ratio of the average output optical power of the transmitter in the high ("1") state to the low ("0") state. The transmitter is driven with a Gigabit Ethernet 1250 MBd 8B/10B encoded serial data pattern. This Optical Extinction Ratio is expressed in decibels (dB) by the relationship  $10\log(P_{high\ avg}/P_{low\ avg})$ .
- These are unfiltered 20-80% values.
- Laser transmitter pulse response characteristics are specified by an eye diagram (Figure 1). The characteristics include rise time, fall time, pulse overshoot, pulse undershoot, and ringing, all of which are controlled to prevent excessive degradation of the receiver sensitivity. These parameters are specified by the referenced Gigabit Ethernet eye diagram using the required filter. The output optical waveform complies with the requirements of the eye mask discussed in section 38.6.5 and Fig. 38-2 of IEEE 802.3z.
- CPR is measured in accordance with EIA/TIA-526-14A as referenced in 802.3z, section 38.6.10.
- TP refers to the compliance point specified in 802.3z, section 38.2.1.
- The receive sensitivity is measured using a worst case extinction ratio penalty while sampling at the center of the eye.
- The stressed receiver sensitivity is measured using the conformance test signal defined in 802.3z, section 38.6.11. The conformance test signal is conditioned by applying deterministic jitter and intersymbol interference.
- The stressed receiver jitter is measured using the conformance test signal defined in 802.3z, section 38.6.11 and set to an average optical power 0.5 dB greater than the specified stressed receiver sensitivity.
- The 3 dB electrical bandwidth of the receiver is measured using the technique outlined in 802.3z, section 38.6.12.
- Return loss is defined as the minimum attenuation (dB) of received optical power for energy reflected back into the optical fiber.



## HFCT-53D5 Family, 1300 nm FP/Laser

### Transmitter Electrical Characteristics

( $T_A = 0^\circ\text{C}$  to  $+70^\circ\text{C}$ ,  $V_{CC} = 4.75\text{ V}$  to  $5.25\text{ V}$ )

Parameter	Symbol	Min.	Typ.	Max.	Unit	Reference
Supply Current	$I_{\text{CCT}}$		65	130	mA	
Power Dissipation	$P_{\text{DIST}}$		0.35	0.68	W	
Data Input Current – Low	$I_{\text{IL}}$	-350	0		mA	
Data Input Current – High	$I_{\text{IH}}$		16	350	mA	

### Receiver Electrical Characteristics

( $T_A = 0^\circ\text{C}$  to  $+70^\circ\text{C}$ ,  $V_{CC} = 4.75\text{ V}$  to  $5.25\text{ V}$ )

Parameter	Symbol	Min.	Typ.	Max.	Unit	Reference
Supply Current	$I_{\text{CCR}}$		120	140	mA	
Power Dissipation	$P_{\text{DISR}}$		0.53	0.68	W	1
Data Output Voltage – Low	$V_{\text{OL}} - V_{\text{CC}}$	-1.950		-1.620	V	2
Data Output Voltage – High	$V_{\text{OH}} - V_{\text{CC}}$	-1.045		-0.740	V	2
Data Output Rise Time	$t_r$			0.40	ns	3
Data Output Fall Time	$t_f$			0.40	ns	3
Signal Detect Output Voltage – Low	$V_{\text{OL}} - V_{\text{CC}}$	-1.950		-1.620	V	2
Data Output Voltage – High	$V_{\text{OH}} - V_{\text{CC}}$	-1.045		-0.740	V	2

#### Notes:

1. Power dissipation value is the power dissipated in the receiver itself. It is calculated as the sum of the products of  $V_{\text{CC}}$  and  $I_{\text{CC}}$  minus the sum of the products of the output voltages and currents.
2. These outputs are compatible with 10 K, 10 KH, and 100 K ECL and PECL inputs.
3. These are 20-80% values.

## HFCT-53D5 Family, 1300 nm FP-Laser

### Transmitter Optical Characteristics

( $T_A = 0^\circ\text{C}$  to  $+70^\circ\text{C}$ ,  $V_{CC} = 4.75\text{ V}$  to  $5.25\text{ V}$ )

Parameter		Symbol	Min.	Typ.	Max.	Unit	Reference
Output Optical Power	9 mm SMF	$P_{OUT}$	-9.5		-3	dBm	1
	62.5 mm MMF		-11.5		-3		
	50 mm MMF		-11.5		-3		
Optical Extinction Ratio			9			dB	2
Center Wavelength		$\lambda_C$	1285		1343	nm	
Spectral Width – rms		$s$			2.8	nm rms	
Optical Rise/Fall Time		$t_r/t_f$			0.26	ns	3, 4, Fig. 1
RIN <sub>12</sub>					-120	dB/Hz	
Total Transmitter Jitter Added at TP2					227	ps	5

### Receiver Optical Characteristics

( $T_A = 0^\circ\text{C}$  to  $+70^\circ\text{C}$ ,  $V_{CC} = 4.75\text{ V}$  to  $5.25\text{ V}$ )

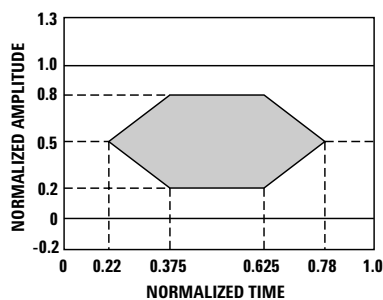
Parameter		Symbol	Min.	Typ.	Max.	Unit	Reference
Input Optical Power		$P_{IN}$	-20		-3	dBm avg.	6
Stressed Receiver Sensitivity					-14.4	dBm avg.	7
Stressed Receiver Eye Opening at TP4			201			ps	5, 8
Receive Electrical 3 dB Upper Cutoff Frequency					1500	MHz	9
Operating Center Wavelength		$\lambda_C$	1270		1355	nm	
Return Loss			12			dB	10
Signal Detect – Asserted		$P_A$			-20	dBm avg.	
Signal Detect – Deasserted		$P_D$	-30			dBm avg.	
Signal Detect – Hysteresis		$P_A - P_D$	1.5			dB	

#### Notes:

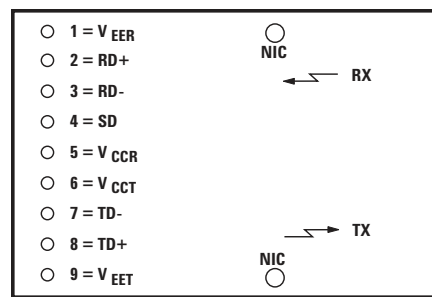
1. The maximum Optical Output Power complies with the IEEE 802.3z specification, and is class 1 laser eye safe.
2. Optical Extinction Ratio is defined as the ratio of the average output optical power of the transmitter in the high ("1") state to the low ("0") state. The transmitter is driven with a Gigabit Ethernet 1250 MBd 8B/10B encoded serial data pattern. This Optical Extinction Ratio is expressed in decibels (dB) by the relationship  $10\log(P_{high\ avg}/P_{low\ avg})$ .
3. These are unfiltered 20-80% values.
4. Laser transmitter pulse response characteristics are specified by an eye diagram (Figure 2). The characteristics include rise time, fall time, pulse overshoot, pulse undershoot, and ringing, all of which are controlled to prevent excessive degradation of the receiver sensitivity. These parameters are specified by the referenced Gigabit Ethernet eye diagram using the required filter. The output optical waveform complies with the requirements of the eye mask discussed in section 38.6.5 and Fig. 38-2 of IEEE 802.3z.
5. TP refers to the compliance point specified in 802.3z, section 38.2.1.
6. The receive sensitivity is measured using a worst case extinction ratio penalty while sampling at the center of the eye.
7. The stressed receiver sensitivity is measured using the conformance test signal defined in 802.3z, section 38.6.11. The conformance test signal is conditioned by applying deterministic jitter and intersymbol interference.
8. The stressed receiver jitter is measured using the conformance test signal defined in 802.3z, section 38.6.11 and set to an average optical power 0.5 dB greater than the specified stressed receive sensitivity.
9. The 3 dB electrical bandwidth of the receiver is measured using the technique outlined in 802.3z, section 38.6.12.
10. Return loss is defined as the minimum attenuation (dB) of received optical power for energy reflected back into the optical fiber.

**Table 1. Pinout Table**

Pin	Symbol	Functional Description
Mounting Pins		The mounting pins are provided for transceiver mechanical attachment to the circuit board. They are embedded in the nonconductive plastic housing and are not connected to the transceiver internal circuit, nor is there a guaranteed connection to the metallized housing in the EM and FM versions. They should be soldered into plated-through holes on the printed circuit board.
1	$V_{EER}$	Receiver Signal Ground Directly connect this pin to receiver signal ground plane. (For HFBR-53D5, $V_{EER} = V_{EET}$ )
2	RD+	Receiver Data Out RD+ is an open-emitter output circuit. Terminate this high-speed differential PECL output with standard PECL techniques at the follow-on device input pin.
3	RD-	Receiver Data Out Bar RD- is an open-emitter output circuit. Terminate this high-speed differential PECL output with standard PECL techniques at the follow-on device input pin.
4	SD	Signal Detect Normal optical input levels to the receiver result in a logic "1" output, $V_{OH}$ , asserted. Low input optical levels to the receiver result in a fault condition indicated by a logic "0" output $V_{OH}$ , deasserted. Signal Detect is a single-ended PECL output. SD can be terminated with standard PECL techniques via 50 $\Omega$ to $V_{CCR} - 2V$ . Alternatively, SD can be loaded with a 270 $\Omega$ resistor to $V_{EER}$ to conserve electrical power with small compromise to signal quality. If Signal Detect output is not used, leave it open-circuited. This Signal Detect output can be used to drive a PECL input on an upstream circuit, such as, Signal Detect input or Loss of Signal-bar.
5	$V_{CCR}$	Receiver Power Supply Provide +5 Vdc via the recommended receiver power supply filter circuit. Locate the power supply filter circuit as close as possible to the $V_{CCR}$ pin.
6	$V_{CCT}$	Transmitter Power Supply Provide +5 Vdc via the recommended transmitter power supply filter circuit. Locate the power supply filter circuit as close as possible to the $V_{CCT}$ pin.
7	TD-	Transmitter Data In-Bar Terminate this high-speed differential PECL input with standard PECL techniques at the transmitter input pin.
8	TD+	Transmitter Data In Terminate this high-speed differential PECL input with standard PECL techniques at the transmitter input pin.
9	$V_{EET}$	Transmitter Signal Ground Directly connect this pin to the transmitter signal ground plane.

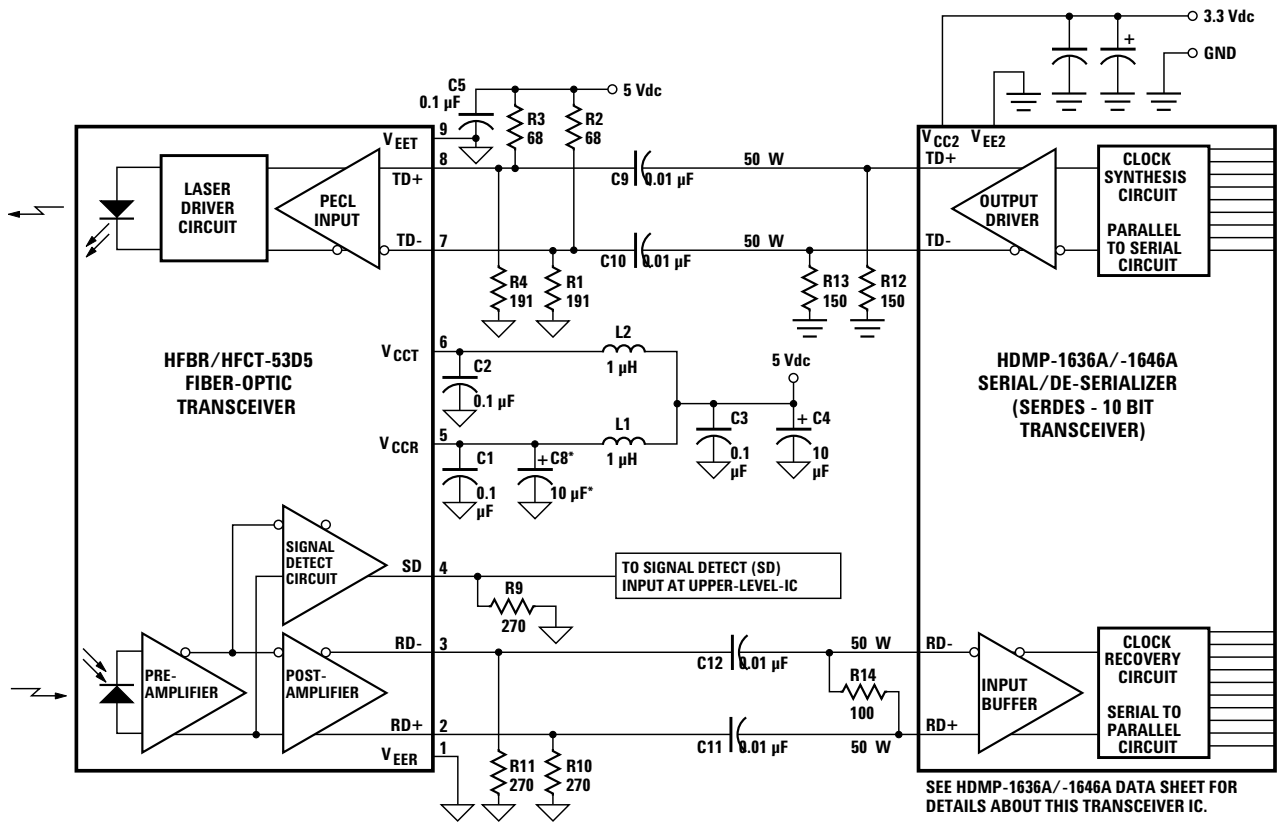


**Figure 1. Transmitter Optical Eye Diagram Mask.**



**TOP VIEW**  
NIC = NO INTERNAL CONNECTION (MOUNTING PINS)

**Figure 2. Pin-Out.**



NOTES:  
 \*C8 IS AN OPTIONAL BYPASS CAPACITOR FOR ADDITIONAL LOW-FREQUENCY NOISE FILTERING.  
 USE SURFACE-MOUNT COMPONENTS FOR OPTIMUM HIGH-FREQUENCY PERFORMANCE.  
 USE 50 W MICROSTRIP OR STRIPLINE FOR SIGNAL PATHS.  
 LOCATE 50 W TERMINATIONS AT THE INPUTS OF RECEIVING UNITS.

Figure 3. Recommended Gigabit/sec Ethernet HFBR/HFCT-53D5 Fiber-Optic Transceiver and HDMP-1636A/1646A SERDES Integrated Circuit Transceiver Interface and Power Supply Filter Circuits.

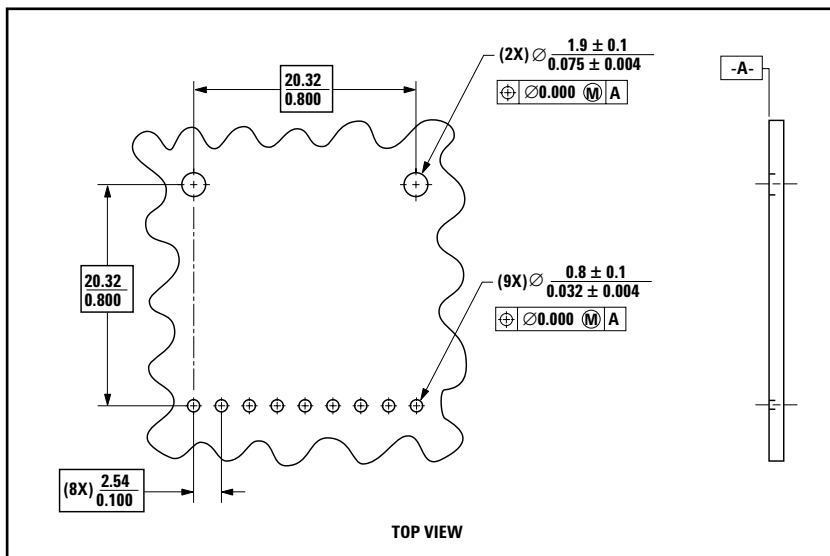


Figure 4. Recommended Board Layout Hole Pattern.

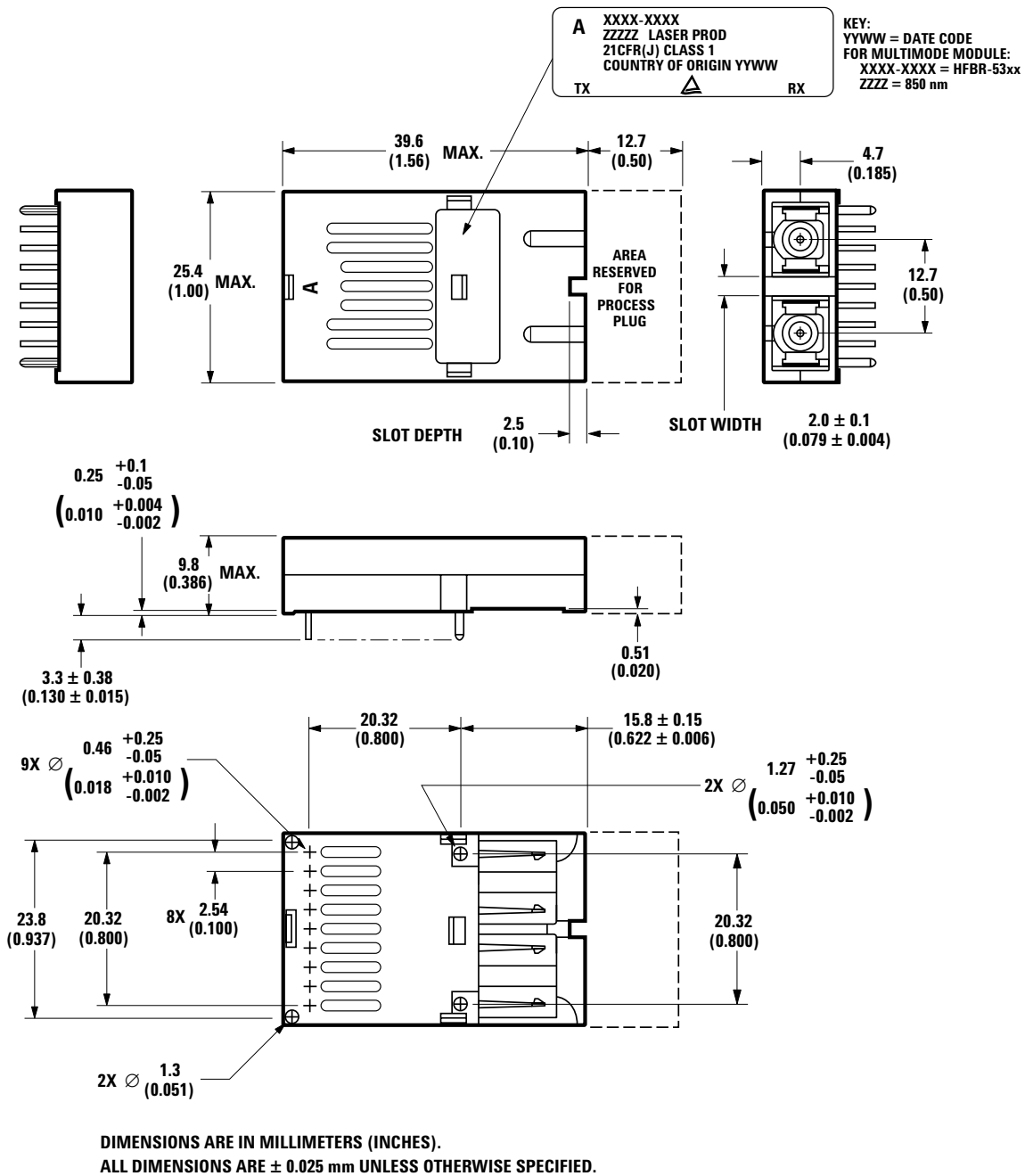
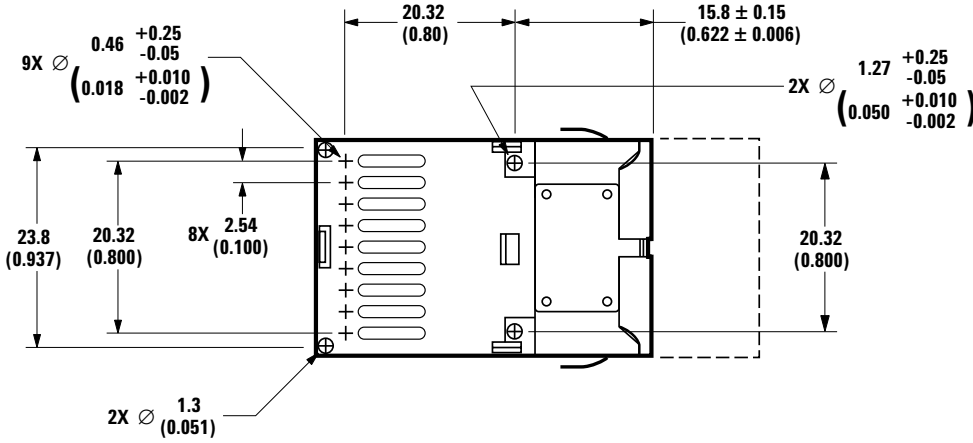
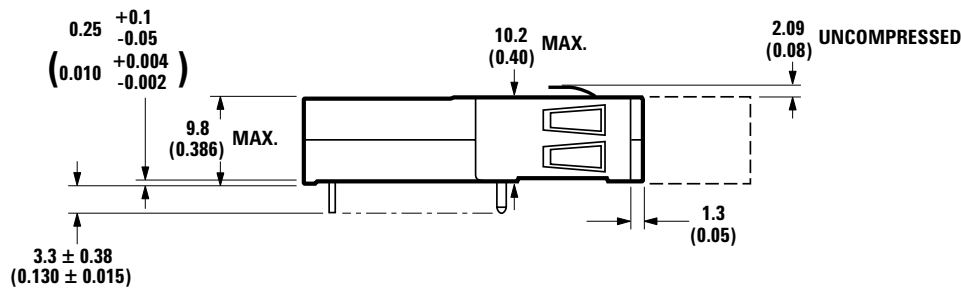
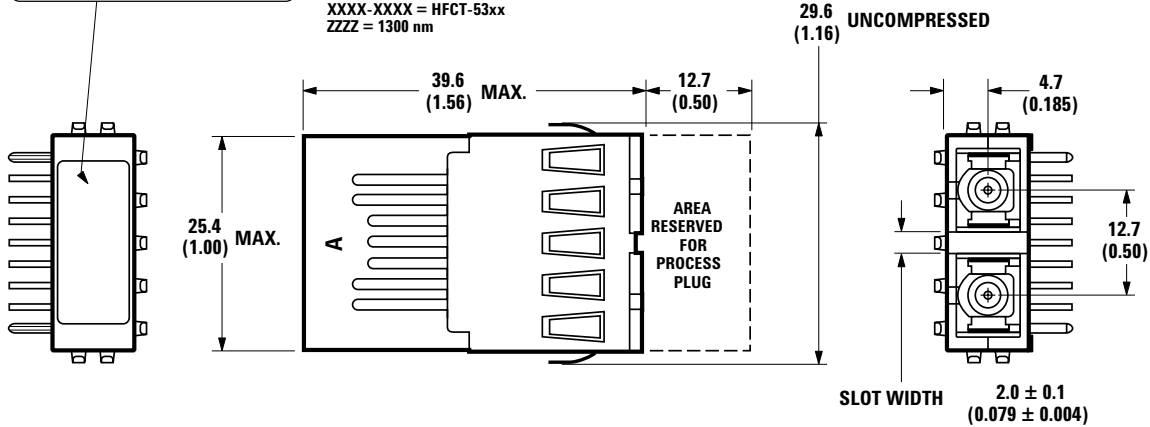


Figure 5. Package Outline Drawing for HFBR-53D5.

A XXXX-XXXX  
 ZZZZ LASER PROD  
 21CFR(J) CLASS 1  
 COUNTRY OF ORIGIN YYWW

KEY:  
 YYWW = DATE CODE  
 FOR MULTIMODE MODULE:  
 XXXX-XXXX = HFBR-53xx  
 ZZZZ = 850 nm  
 FOR SINGLEMODE MODULES:  
 XXXX-XXXX = HFCT-53xx  
 ZZZZ = 1300 nm



DIMENSIONS ARE IN MILLIMETERS (INCHES).  
 ALL DIMENSIONS ARE  $\pm 0.025$  mm UNLESS OTHERWISE SPECIFIED.

Figure 6. Package Outline for HFBR/HFCT-53D5EM.

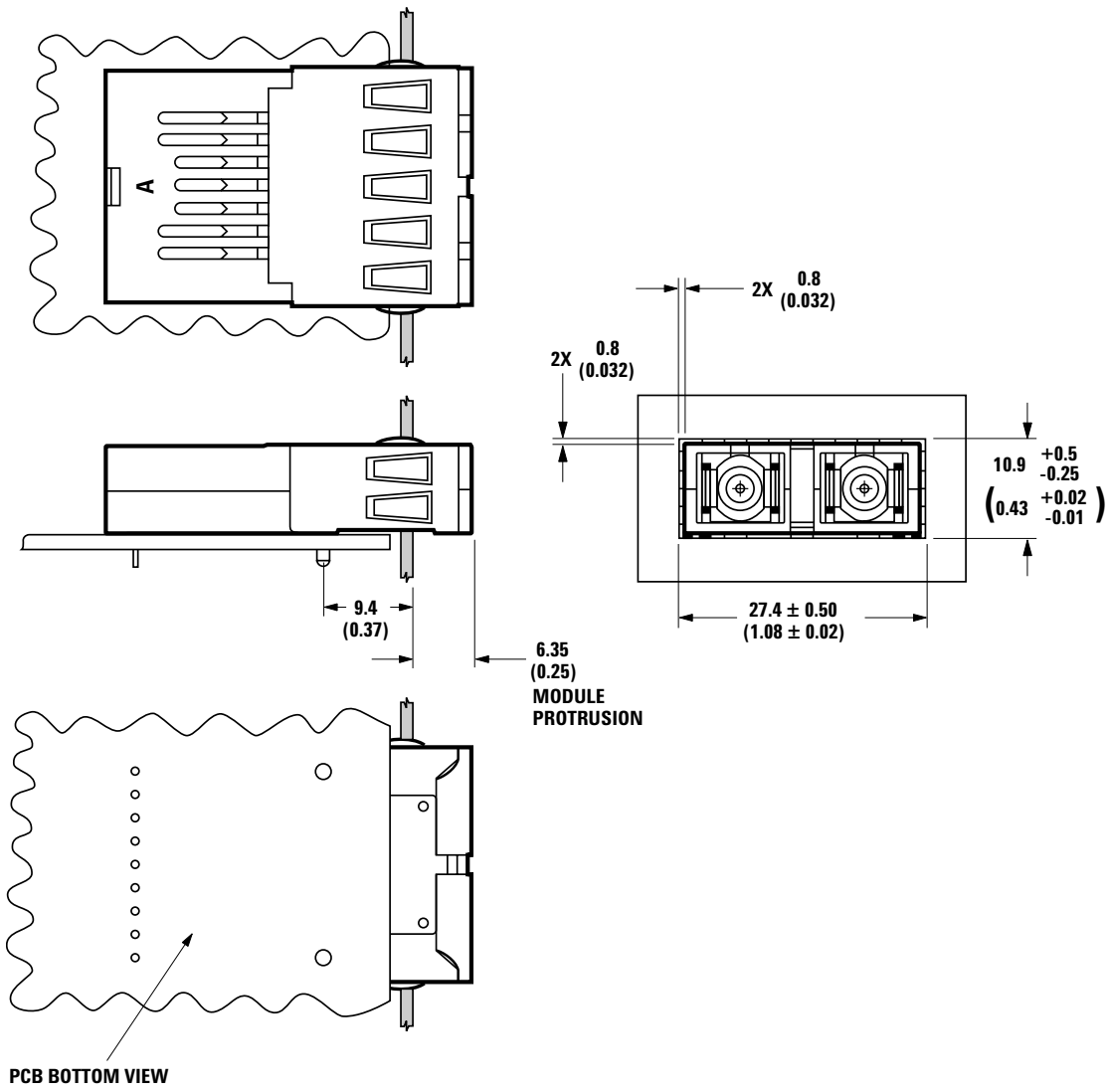

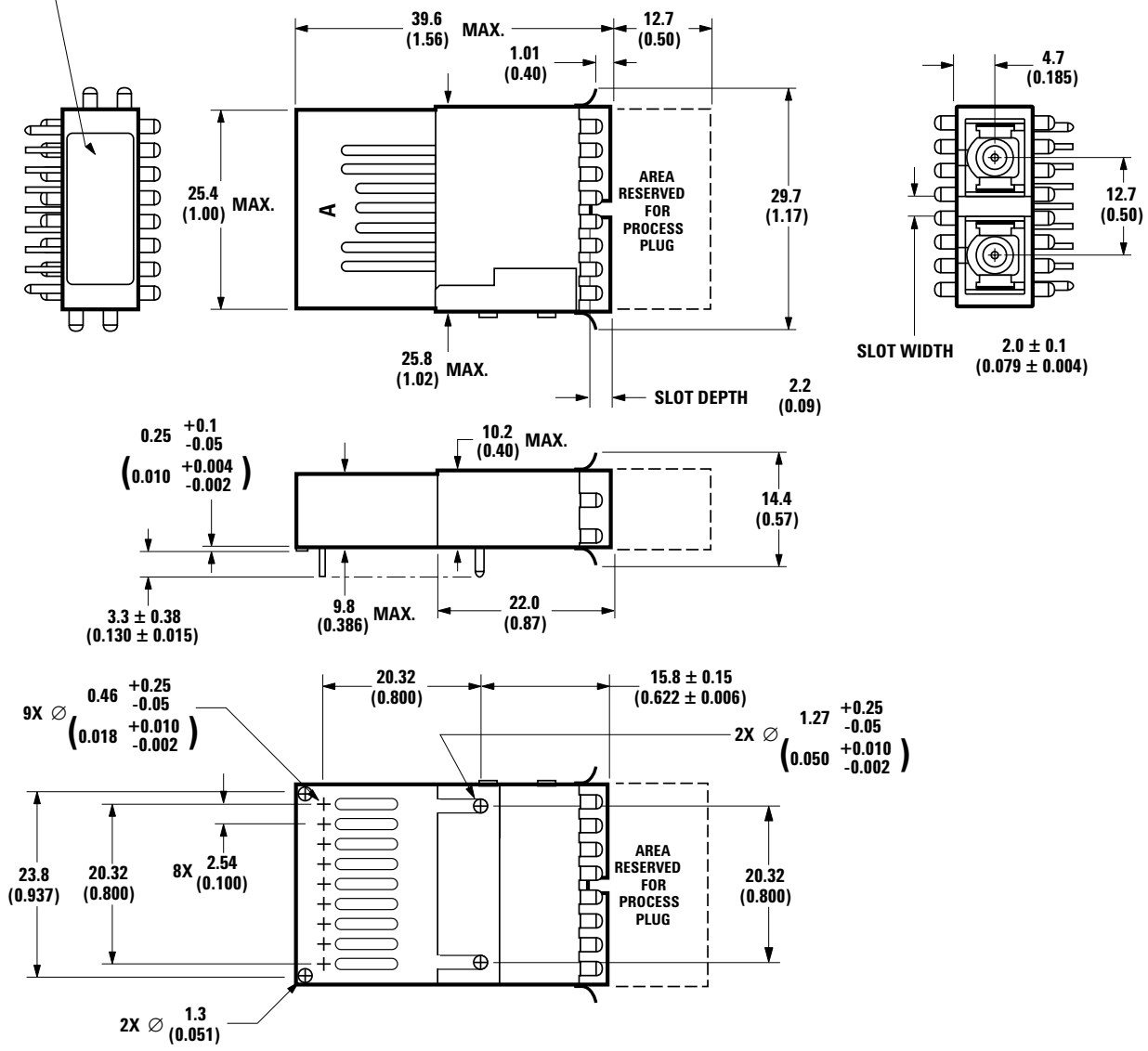


Figure 7. Suggested Module Positioning and Panel Cut-out for HFBR/HFCT-53D5EM.

A  
 XXXX-XXXX  
 ZZZZ LASER PROD  
 21CFR(J) CLASS 1  
 COUNTRY OF ORIGIN YYWW  
 TX  RX

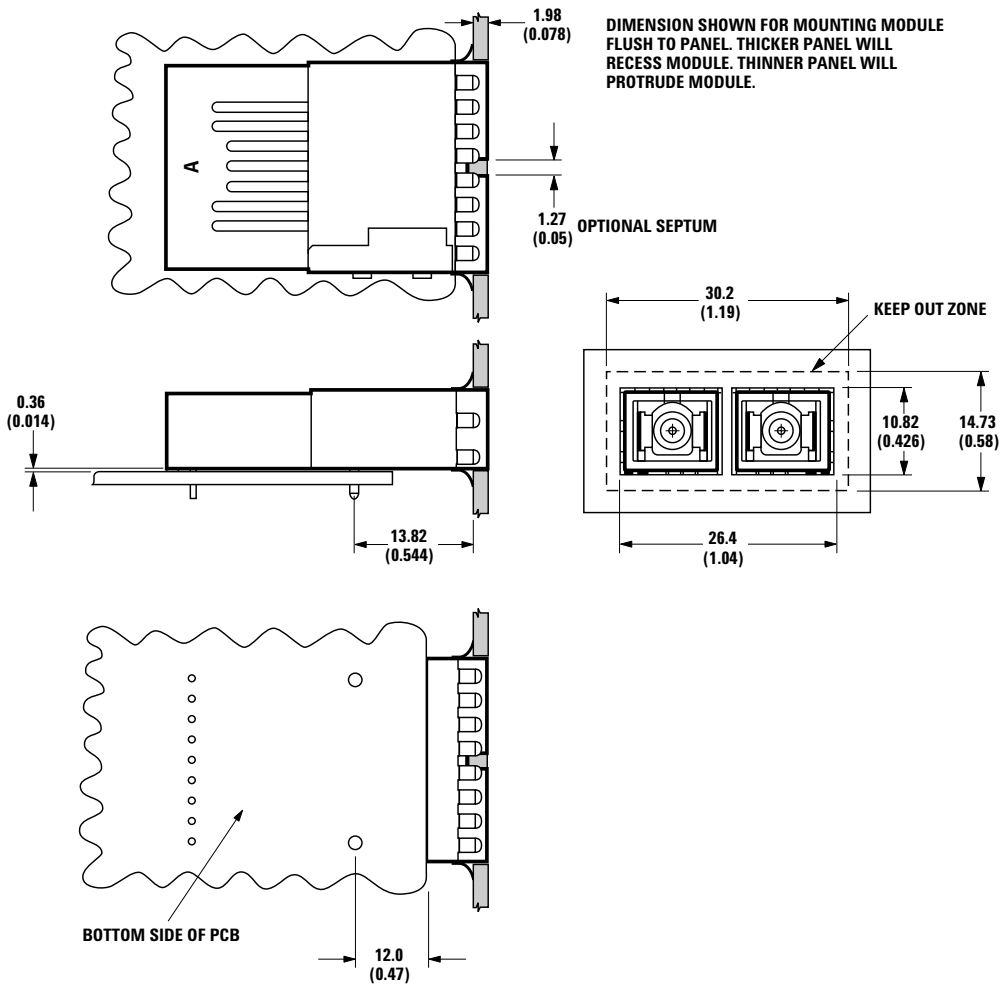
KEY:  
 YYWW = DATE CODE  
 FOR MULTIMODE MODULE:  
 XXXX-XXXX = HFBR-53xx  
 ZZZZ = 850 nm  
 FOR SINGLEMODE MODULES:  
 XXXX-XXXX = HFCT-53xx  
 ZZZZ = 1300 nm



DIMENSIONS ARE IN MILLIMETERS (INCHES).  
 ALL DIMENSIONS ARE ± 0.025 mm UNLESS OTHERWISE SPECIFIED.

Figure 8. Package Outline for HFBR/HFCT-53D5FM.





DIMENSIONS ARE IN MILLIMETERS (INCHES).  
ALL DIMENSIONS ARE  $\pm 0.025$  mm UNLESS OTHERWISE SPECIFIED.

**Figure 9. Suggested Module Positioning and Panel Cut-out for HFBR/HFCT-53D5FM.**

## Ordering Information

### 850 nm VCSEL (SX – Short Wavelength Laser)

HFBR-53D5 No shield, plastic housing.

HFBR-53D5EM Extended/protruding shield, metallized housing.

HFBR-53D5FM Flush shield, metallized housing.

### 1300 nm FP Laser (LX – Long Wavelength Laser)

HFCT-53D5EM Extended/protruding shield, metallized housing.

HFCT-53D5FM Flush shield, metallized housing.

For product information and a complete list of distributors, please go to our web site: [www.avagotech.com](http://www.avagotech.com)

Avago, Avago Technologies, and the A logo are trademarks of Avago Technologies in the United States and other countries.  
Data subject to change. Copyright © 2005-2013 Avago Technologies. All rights reserved. Obsoletes 5968-3183E  
AV02-3588EN - January 30, 2013

**AVAGO**  
TECHNOLOGIES