



16-Bit 250kHz Sampling CMOS ANALOG-to-DIGITAL CONVERTER

FEATURES

- 250kHz SAMPLING RATE
- COMPLETE WITH S/H, REF, CLOCK, ETC.
- 96dB min SFDR WITH 100kHz INPUT
- 84dB min SINAD
- $\pm 2.5V$ INPUT RANGE
- 28-LEAD SOIC

APPLICATIONS

- WIRELESS BASE STATIONS
- SPECTRUM ANALYSIS
- IMAGING SYSTEMS
- DATA ACQUISITION

DESCRIPTION

The ADS7811 is a complete 16-bit sampling analog-to-digital (A/D) converter featuring excellent AC performance and a 250kHz throughput rate. The design includes a 16-bit capacitor-based SAR A/D converter with an inherent sample and hold (S/H), a precision reference, and an internal clock. Spurious-free dynamic range with a 100kHz full-scale sinewave input is typically greater than 100dB. The $\pm 2.5V$ input range allows development of precision systems using only $\pm 5V$ supplies. The converter is available in a 28-lead SOIC package specified for operation over the industrial $-25^{\circ}C$ to $+85^{\circ}C$ temperature range.

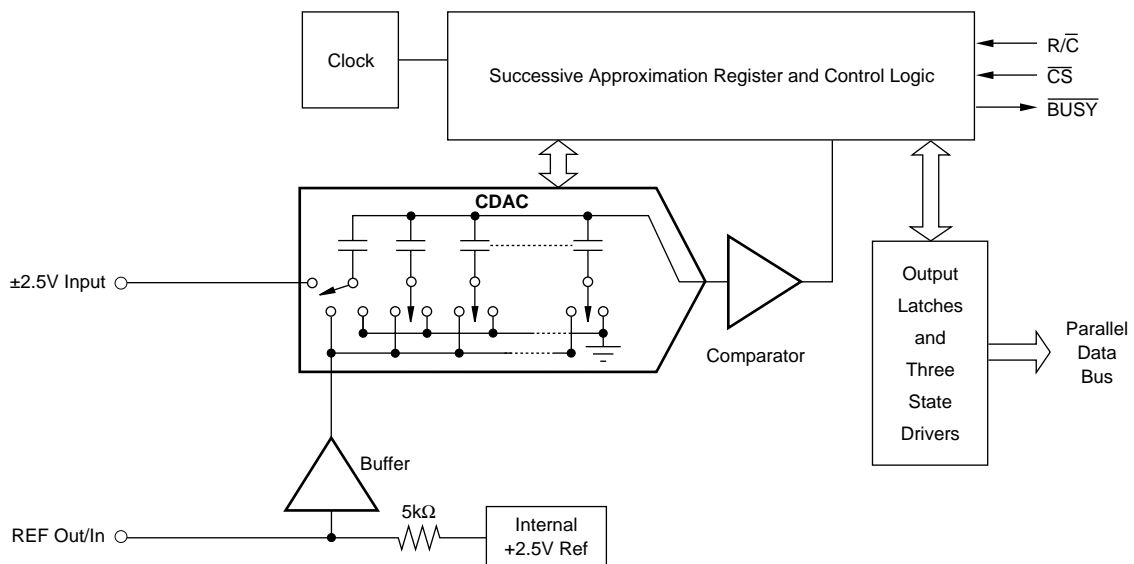

Please be aware that an important notice concerning availability, standard warranty, and use in critical applications of Texas Instruments semiconductor products and disclaimers thereto appears at the end of this data sheet.

All trademarks are the property of their respective owners.

ABSOLUTE MAXIMUM RATINGS

Analog Inputs: V_{IN}	$-V_S - 0.3V$ to $+V_S + 0.3V$
REF	$-0.3V$ to $+V_S + 0.3V$
CAP	Indefinite Short to GND Momentary Short to $+V_S$
$+V_S$	7V
$-V_S$	-7V
Digital Inputs	$-0.3V$ to $+V_S + 0.3V$
Maximum Junction Temperature	+165°C
Internal Power Dissipation	825mW
Lead Temperature (soldering, 10s)	+300°C



ELECTROSTATIC DISCHARGE SENSITIVITY

This integrated circuit can be damaged by ESD. Texas Instruments recommends that all integrated circuits be handled with appropriate precautions. Failure to observe proper handling and installation procedures can cause damage.

ESD damage can range from subtle performance degradation to complete device failure. Precision integrated circuits may be more susceptible to damage because very small parametric changes could cause the device not to meet its published specifications.

PACKAGE/ORDERING INFORMATION⁽¹⁾

PRODUCT	PACKAGE	PACKAGE DESIGNATOR	TEMPERATURE RANGE
ADS7811U	28-Pin SOIC	DW	-25°C to +85°C

NOTE: (1) For the most current package and ordering information, see the Package Option Addendum at the end of this data sheet, or see the TI web site at www.ti.com.

ELECTRICAL CHARACTERISTICS

At $T_A = -25^{\circ}\text{C}$ to $+85^{\circ}\text{C}$, $f_s = 250\text{kHz}$, $+V_S = +5\text{V}$, and $-V_S = -5\text{V}$, using internal reference, unless otherwise specified.

PARAMETER	CONDITIONS	ADS7811U			UNITS	
		MIN	TYP	MAX		
RESOLUTION				16	Bits	
ANALOG INPUT	After Input Capacitor is Charged		$\pm 2.5\text{V}$		V	
Voltage Range			100		$\text{M}\Omega$	
Impedance			30		pF	
Capacitance						
THROUGHPUT SPEED	Acquire and Convert			4.0	μs	
Conversion Cycle Throughput Rate		250			kHz	
DC ACCURACY	External 2.5000V Reference External 2.5000V Reference $+V_S \pm 5\%$, $-V_S \pm 5\%$	15		± 6	LSB ⁽¹⁾	
Integral Linearity Error						Bits
No Missing Codes			0.8			LSB
Transition Noise ⁽²⁾					± 0.5	%
Full-Scale Error ⁽³⁾			± 7			$\text{ppm}/^{\circ}\text{C}$
Full-Scale Error Drift			± 0.2			%
Full-Scale Error ⁽³⁾			2			$\text{ppm}/^{\circ}\text{C}$
Full-Scale Error Drift			± 2		± 10	mV
Bipolar Zero Error			± 6			$\text{ppm}/^{\circ}\text{C}$
Bipolar Zero Error Drift						LSB
Power-Supply Sensitivity						
AC ACCURACY						
Spurious-Free Dynamic Range	$f_{\text{IN}} = 100\text{kHz}$	96	100		dB ⁽⁴⁾	
Total Harmonic Distortion	$f_{\text{IN}} = 100\text{kHz}$		-98	-94	dB	
Signal-to-(Noise+Distortion)	$f_{\text{IN}} = 100\text{kHz}$	82	87		dB	
	-60dB Input		28		dB	
Signal-to-Noise	$f_{\text{IN}} = 100\text{kHz}$	82	87		dB	
Usable Bandwidth ⁽⁵⁾			1		MHz	
Aperture Delay			40		ns	
REFERENCE						
Internal Reference Voltage		2.48	2.5	2.52	V	
Internal Reference Source Current			1		μA	
Internal Reference Drift			15		$\text{ppm}/^{\circ}\text{C}$	
External Reference Voltage Range			2.5		V	
External Reference Current Drain	$V_{\text{REF}} = +2.5\text{V}$			100	μA	
DIGITAL INPUTS						
Logic Levels						
V_{IL}		-0.3		+0.8	V	
V_{IH}		+2.8		$+V_S + 0.3\text{V}$	V	
I_{IL}				± 10	μA	
I_{IH}				± 10	μA	
DIGITAL OUTPUTS						
Data Format			Parallel 16 bits			
Data Coding			Binary Two's Complement			
V_{OL}	$I_{\text{SINK}} = 1.6\text{mA}$			+0.4	V	
V_{OH}	$I_{\text{SOURCE}} = 200\mu\text{A}$	+4			V	
Leakage Current	High-Z State, $V_{\text{OUT}} = 0\text{V}$ to V_{DIG}			± 5	μA	
Output Capacitance	High-Z State			15	pF	
DIGITAL TIMING						
Bus Access Time				83	ns	
Bus Relinquish Time				83	ns	
POWER SUPPLIES						
$+V_S$		+4.75	+5	+5.25	V	
$-V_S$		-5.25	-5	-4.75	V	
$+I_S$			+30		mA	
$-I_S$			-10		mA	
Power Dissipation			200	250	mW	
TEMPERATURE RANGE						
Specified Performance		-25		+85	$^{\circ}\text{C}$	
Storage		-55		+125	$^{\circ}\text{C}$	

NOTES: (1) LSB means Least Significant Bit. For the 16-bit, $\pm 2.5\text{V}$ input ADS7811, one LSB is $76\mu\text{V}$.

(2) Typical rms noise at worst case transitions and temperatures.

(3) Full-scale error is the worst case of -Full-Scale or +Full-Scale untrimmed deviation from ideal first and last code transitions, divided by the transition voltage (not divided by the full-scale range) and includes the effect of offset error.

(4) All specifications in dB are referred to a full-scale $\pm 2.5\text{V}$ input.

(5) Usable Bandwidth defined as Full-Scale input frequency at which Signal-to-(Noise+Distortion) degrades to 60dB, or 10 bits of accuracy.

PIN CONFIGURATION

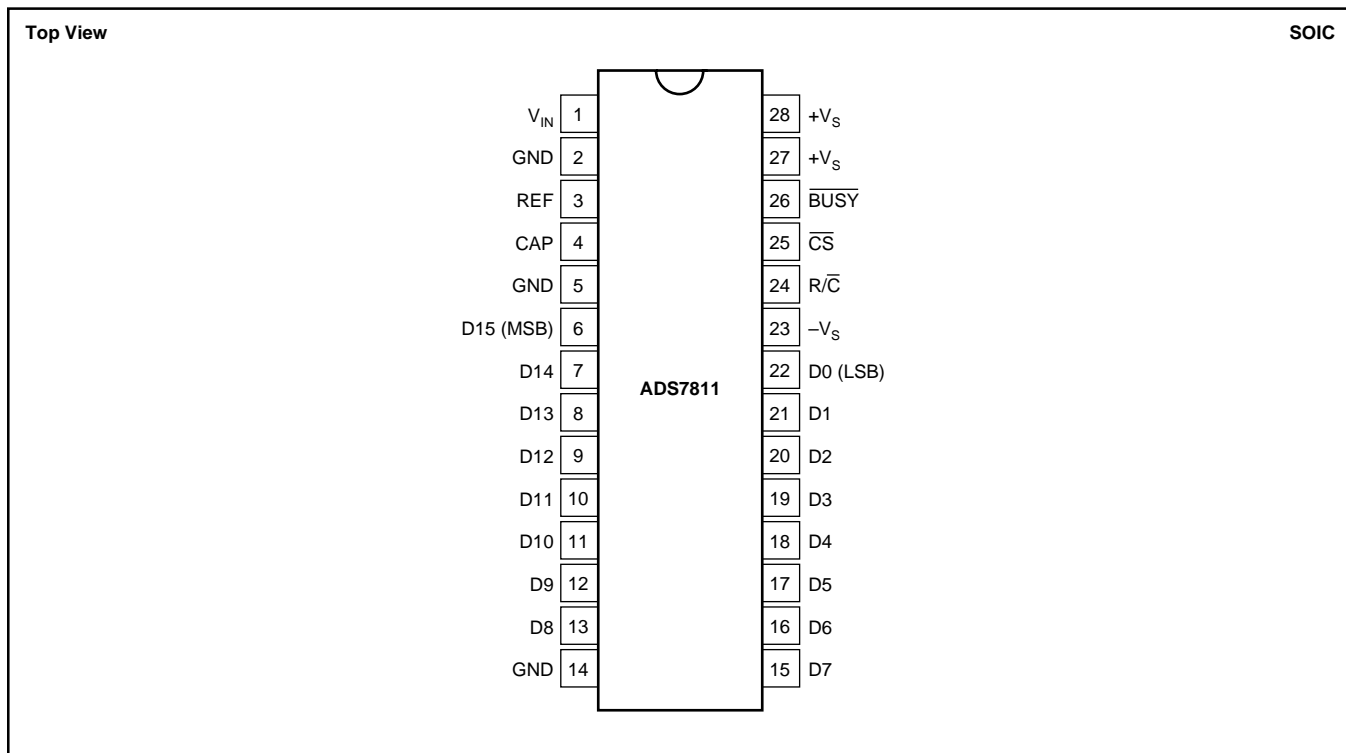

PIN #	NAME	DESCRIPTION
1	V _{IN}	Analog Input. Full-scale input range is $\pm 2.5V$.
2	GND	Ground.
3	REF	Reference Input/Output. Outputs internal reference of +2.5V nominal. Can also be driven by external system reference. In both cases, connect to ground with a 0.1 μF ceramic capacitor in parallel with 2.2 μF tantalum capacitor.
4	CAP	Reference compensation capacitor. Use a parallel combination of a 0.1 μF ceramic capacitor and a 2.2 μF tantalum capacitor.
5	GND	Ground.
6	D15 (MSB)	Data Bit 15. Most Significant Bit (MSB) of conversion results. Hi-Z state when \overline{CS} is HIGH, when R/\overline{C} is LOW or when a conversion is in progress.
7	D14	Data Bit 14. Hi-Z state when \overline{CS} is HIGH, when R/\overline{C} is LOW or when a conversion is in progress.
8	D13	Data Bit 13. Hi-Z state when \overline{CS} is HIGH, when R/\overline{C} is LOW or when a conversion is in progress.
9	D12	Data Bit 12. Hi-Z state when \overline{CS} is HIGH, when R/\overline{C} is LOW or when a conversion is in progress.
10	D11	Data Bit 11. Hi-Z state when \overline{CS} is HIGH, when R/\overline{C} is LOW or when a conversion is in progress.
11	D10	Data Bit 10. Hi-Z state when \overline{CS} is HIGH, when R/\overline{C} is LOW or when a conversion is in progress.
12	D9	Data Bit 9. Hi-Z state when \overline{CS} is HIGH, when R/\overline{C} is LOW or when a conversion is in progress.
13	D8	Data Bit 8. Hi-Z state when \overline{CS} is HIGH, when R/\overline{C} is LOW or when a conversion is in progress.
14	GND	Ground.
15	D7	Data Bit 7. Hi-Z state when \overline{CS} is HIGH, when R/\overline{C} is LOW or when a conversion is in progress.
16	D6	Data Bit 6. Hi-Z state when \overline{CS} is HIGH, when R/\overline{C} is LOW or when a conversion is in progress.
17	D5	Data Bit 5. Hi-Z state when \overline{CS} is HIGH, when R/\overline{C} is LOW or when a conversion is in progress.
18	D4	Data Bit 4. Hi-Z state when \overline{CS} is HIGH, when R/\overline{C} is LOW or when a conversion is in progress.
19	D3	Data Bit 3. Hi-Z state when \overline{CS} is HIGH, when R/\overline{C} is LOW or when a conversion is in progress.
20	D2	Data Bit 2. Hi-Z state when \overline{CS} is HIGH, when R/\overline{C} is LOW or when a conversion is in progress.
21	D1	Data Bit 1. Hi-Z state when \overline{CS} is HIGH, when R/\overline{C} is LOW or when a conversion is in progress.
22	D0 (LSB)	Data Bit 0. Least Significant Bit (LSB) of conversion results. Hi-Z state when \overline{CS} is HIGH, when R/\overline{C} is LOW or when a conversion is in progress.
23	-V _S	Negative supply input. Nominally -5V. Decouple to analog ground with 0.1 μF ceramic and 10 μF tantalum capacitors.
24	R/ \overline{C}	Read/convert input. With R/\overline{C} HIGH, \overline{CS} going LOW will enable the output data bits if a conversion is not in progress. With R/\overline{C} LOW, \overline{CS} going LOW will start a conversion if one is not already in progress.
25	\overline{CS}	Chip select. With R/\overline{C} LOW, \overline{CS} going LOW will initiate a conversion if one is not already in progress. With R/\overline{C} HIGH, \overline{CS} going LOW will enable the output data bits if a conversion is not in progress.
26	\overline{BUSY}	Busy output. Falls when a conversion is started, and remains LOW until the conversion is completed. With \overline{CS} LOW and R/\overline{C} HIGH, output data will be valid when \overline{BUSY} rises, so that the rising edge can be used to latch the data. \overline{CS} or R/\overline{C} must be HIGH within 250ns after \overline{BUSY} rises or another conversion will start without time for signal acquisition.
27	+V _S	Positive supply input. Nominally +5V. Connect directly to pin 28.
28	+V _S	Positive supply input. Nominally +5V. Connect directly to pin 27. Decouple to ground with 0.1 μF ceramic and 10 μF tantalum capacitors.

TABLE I. Pin Assignments.

TYPICAL PERFORMANCE CURVES

At $T_A = -25^{\circ}\text{C}$ to $+85^{\circ}\text{C}$, $f_S = 250\text{kHz}$, $+V_S = +5\text{V}$, and $-V_S = -5\text{V}$, using internal reference, unless otherwise specified.

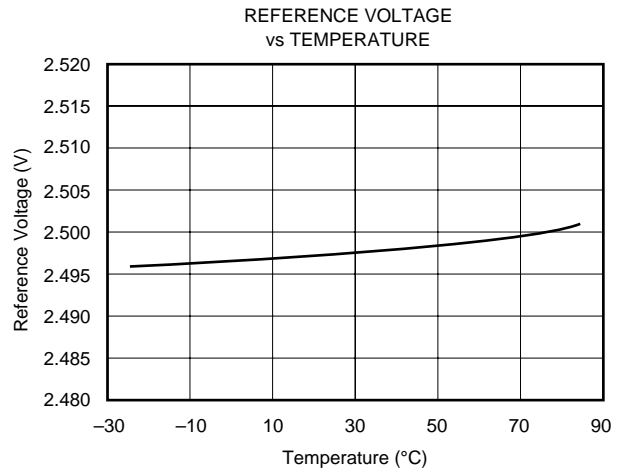
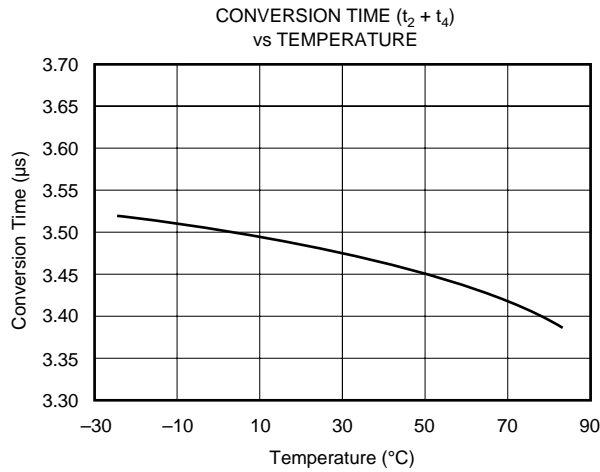
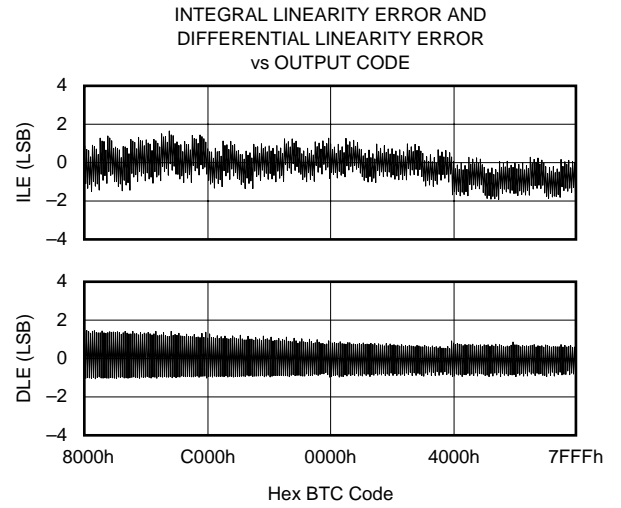
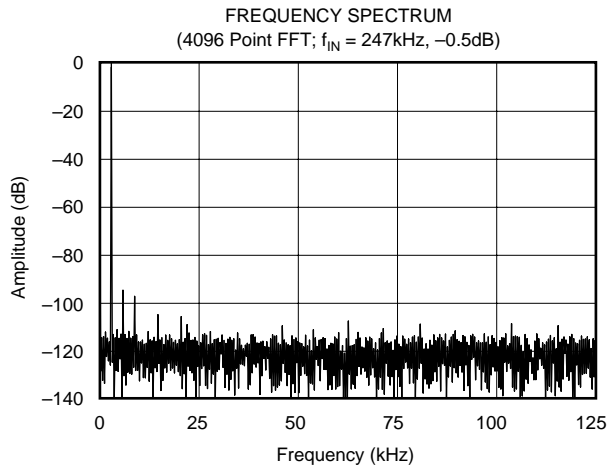
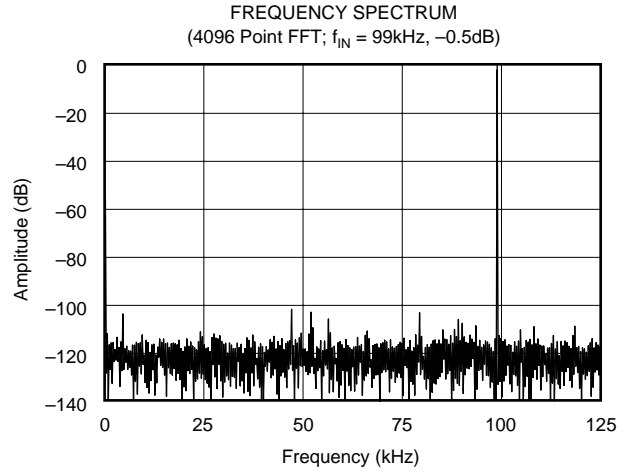
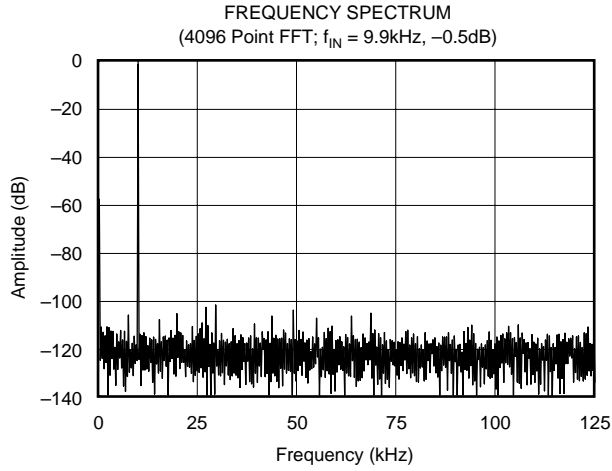

BASIC OPERATION

Figure 1 shows the recommended circuit for operation of the ADS7811. A falling edge on the convert pulse signal places the sample and hold into the hold mode and initiates a conversion. When the conversion is complete, the pins D15 through D0 become active and the result of the conversion

is placed on these outputs. In the circuit shown in Figure 1, the rising edge of $\overline{\text{BUSY}}$ latches the result into the 74HC574s.

After the conversion is complete, the ADS7811 sample and hold returns to the sample mode and begins acquiring the input signal for the next conversion. Allowing $4\mu\text{s}$ between falling edges of the convert pulse signal assures adequate acquisition time for the internal sample and hold.

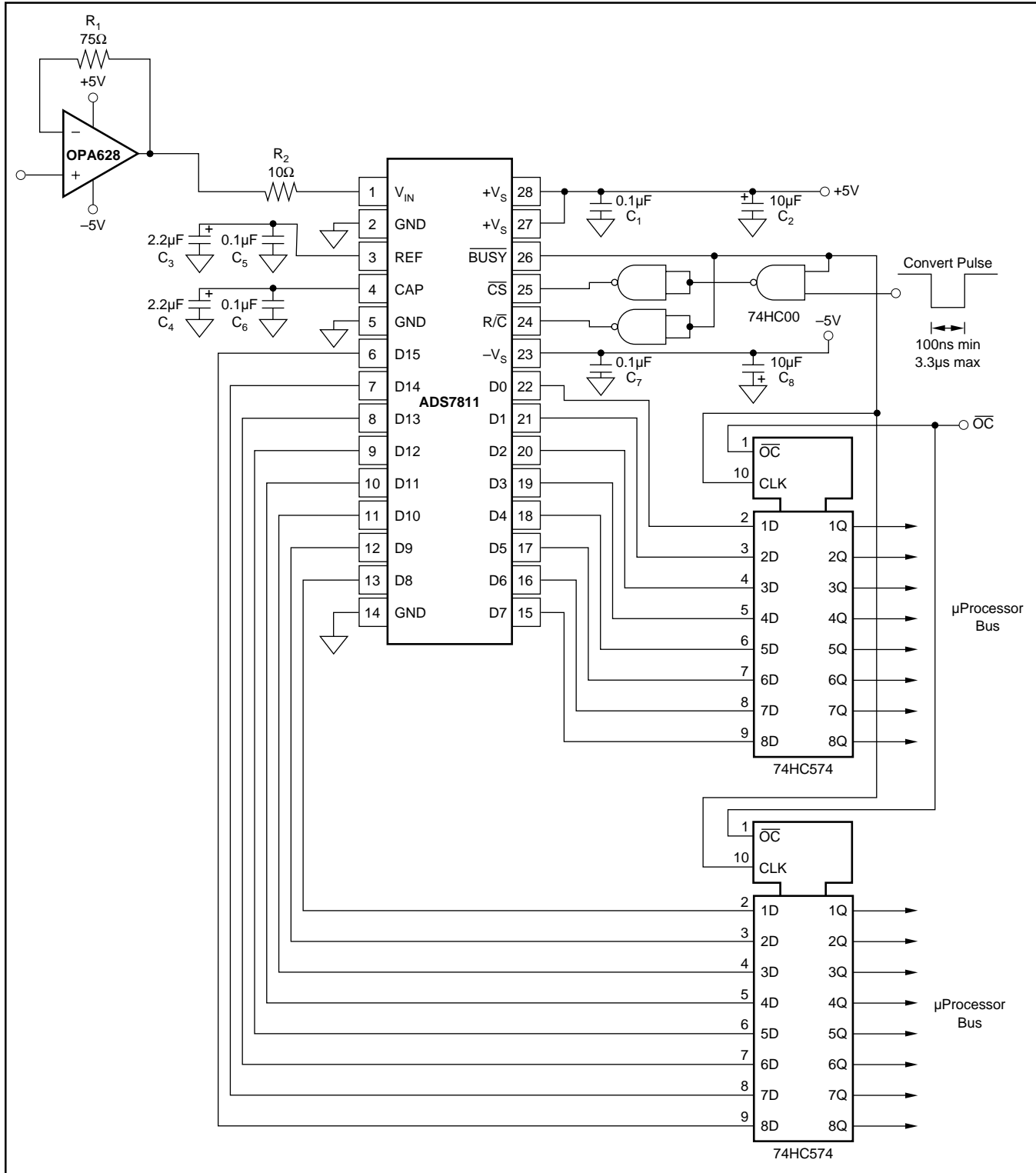

FIGURE 1. Basic Operation.

TIMING

The timing shown in Figure 2 and Table II is the recommended method of operating the ADS7811. The falling edge of \overline{CS} initiates the conversion. During the conversion, the digital outputs are tri-stated and \overline{BUSY} is LOW. Near the end of the conversion, the digital outputs become active with the most recent conversion result. After a brief delay (see time t_{11} in Figure 2 and Table II), \overline{BUSY} rises. The rising edge of \overline{BUSY} is used to latch the digital result in Figure 1.

R/C AND CS

The R/\overline{C} (read/convert) and \overline{CS} signals control the start of conversion and, when a conversion is not in progress, the status of the digital outputs D15 through D0. It is possible to start a conversion by taking \overline{CS} LOW and then taking R/\overline{C} LOW. However, this is not recommended and will result in a significant decrease in signal-to-noise ratio. This is due to

the digital outputs tri-stating while the sample and hold transitions to the hold mode. The change in digital outputs results in noise being coupled onto the hold capacitor.

If a conversion is not in progress or is just about to finish, the digital outputs will be active when R/\overline{C} is HIGH and \overline{CS} is LOW. This is shown in Figure 2 and Figure 3. It is possible to return \overline{CS} HIGH during the initial part of the conversion (as is done with R/\overline{C}) and prevent the digital outputs from becoming active. At a later time, the digital results could be read by taking \overline{CS} LOW. It is also possible to leave R/\overline{C} LOW, take \overline{CS} HIGH during the conversion, and read the results at a later time by taking R/\overline{C} HIGH and \overline{CS} LOW.

Following a conversion, if R/\overline{C} and \overline{CS} are both LOW 250ns after \overline{BUSY} rises, then a new conversion will be initiated without allowing the proper acquisition period for the sample and hold. R/\overline{C} must remain HIGH or \overline{CS} must be taken HIGH within 250ns of \overline{BUSY} rising.

R/\overline{C} and \overline{CS} should remain static prior to that start of conversion and during the later part of a conversion. To start

SYMBOL	DESCRIPTION	MIN	TYP	MAX	UNITS
t_1	\overline{CS} to R/\overline{C} Delay	t_2		200	ns
t_2	\overline{CS} to \overline{BUSY} Delay		40		ns
t_3	Aperture Delay		40		ns
t_4	\overline{BUSY} LOW		3.5		μ s
t_5	R/\overline{C} LOW to \overline{CS} LOW	100			ns
t_6	\overline{BUSY} HIGH to \overline{CS} HIGH			250	ns
t_7	Bus Access Time		10	83	ns
t_8	Bus Relinquish Time			83	ns
t_9	Throughput Time			4	μ s
t_{10}	Conversion Time		3.4		μ s
t_{11}	Data Valid to \overline{BUSY} HIGH	25	35		ns
t_{12}	\overline{CS} to R/\overline{C} Setup Time	40			ns

TABLE II. Conversion Timing.

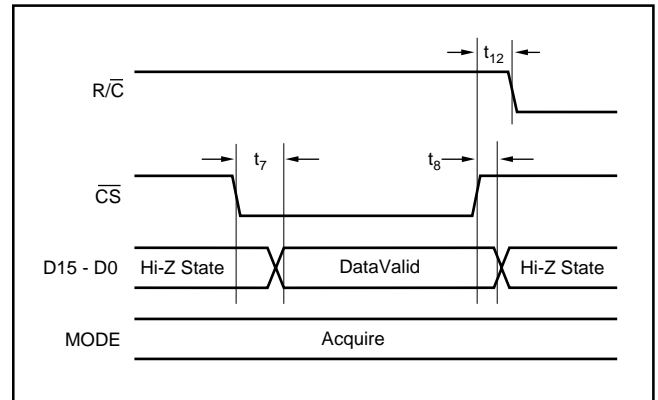

FIGURE 3. Bus Timing.

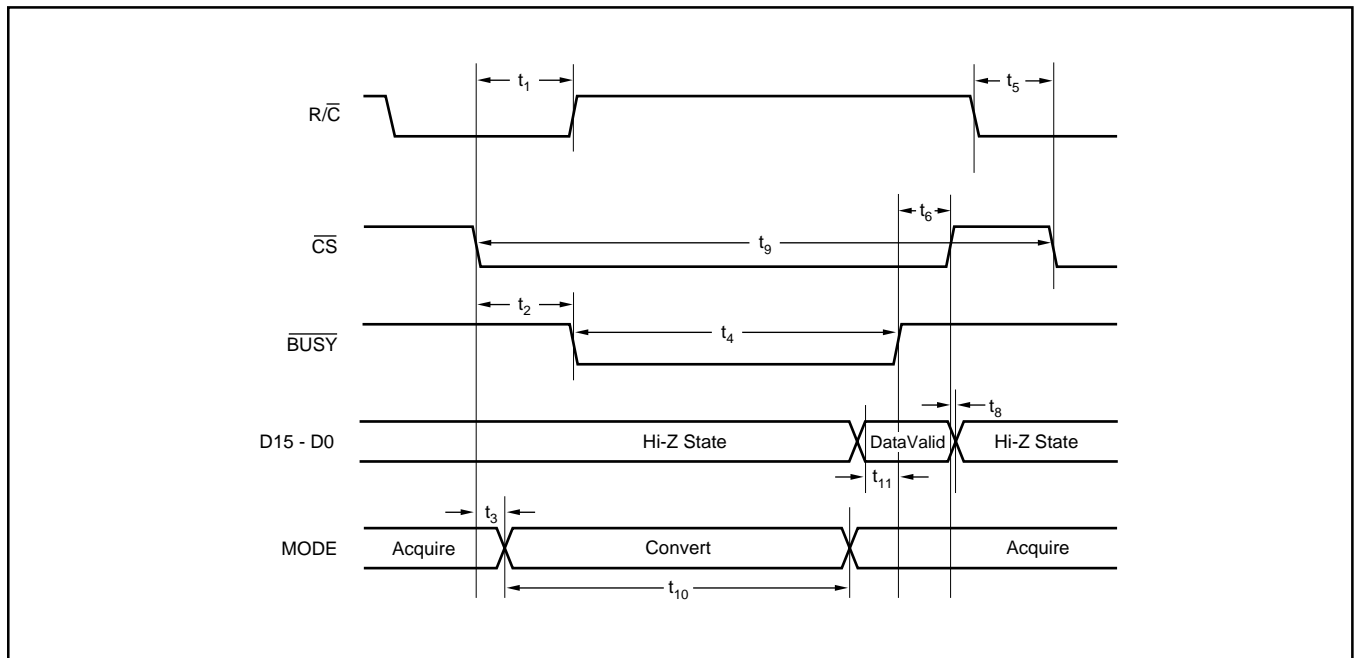

FIGURE 2. ADS7811 Timing.

a conversion, $\overline{R/C}$ should be taken LOW at least 100ns before \overline{CS} is taken LOW. $\overline{R/C}$ and/or \overline{CS} should be taken HIGH during the early part of the conversion, preferably within 200ns of the start of the conversion. If these times are not observed, then there is risk that the transition of these digital signals may affect the conversion result.

The three NAND gates shown in Figure 1 can be used to generate $\overline{R/C}$ and \overline{CS} signals from a single negative going pulse. The pulse must not be longer than 3.3 μ s or a second conversion may be initiated immediately after the first.

BUSY

\overline{BUSY} goes LOW when a conversion is started and remains LOW throughout the conversion. Just prior to \overline{BUSY} going HIGH, the digital outputs become active with the conversion result. Time t_{11} , shown in Figure 2, should provide adequate time for the ADS7811 to drive the digital outputs to a valid logic state before \overline{BUSY} rises. As shown in Figure 1 and 2, the rising edge of \overline{BUSY} can be used to latch the digital result into an external component.

DIGITAL OUTPUT

The ADS7811's digital output is in Binary Two's Complement (BTC) format. Table III shows the relationship between the digital output word and analog input voltage under ideal conditions.

DESCRIPTION	ANALOG INPUT	DIGITAL OUTPUT	
		BINARY TWO'S COMPLEMENT	
		BINARY CODE	HEX CODE
Full Scale Range	$\pm 2.5V$		
Least Significant Bit (LSB)	76 μ V		
+Full Scale (2.5V – 1LSB)	2.499924V	0111 1111 1111 1111	7FFF
Midscale	0V	0000 0000 0000 0000	0000
One LSB below Midscale	-76 μ V	1111 1111 1111 1111	FFFF
-Full Scale	-2.5V	1000 0000 0000 0000	8000

Table III. Ideal Input Voltages and Output Codes.

REFERENCE

The ADS7811 can be operated with the internal 2.5V reference or an external reference. By applying an external reference to the REF pin, the internal reference is bypassed. The reference voltage at REF is buffered internally.

The voltage at the reference input sets the full-scale range of the converter. With the internal 2.5V reference, the input range is $\pm 2.5V$. Thus, the input range of the converter's analog input is simply $\pm V_{REF}$, where V_{REF} is the voltage at the reference input. Because of internal gain and offset error, the input range will not be exactly $\pm V_{REF}$. The full-scale error of the converter with an external reference will typically be 0.25% or less. The bipolar zero error will be similar to that listed in the Electrical Characteristics Table. The range for the external reference is 2.3V to 2.7V. While the ADS7811 will operate using an external reference, the specifications are only ensured when the internal reference is used.

REF PIN

The REF pin itself should be bypassed with a 0.1 μ F ceramic capacitor in parallel with a 2.2 μ F tantalum capacitor. While both capacitors should be physically close to the ADS7811, it is very important that the ceramic capacitor be placed as close as possible.

The REF voltage should not be used to drive a large load or any load which is dynamic. A large load will reduce the reference voltage and the corresponding input range of the converter. A dynamic load will modulate the reference voltage and this modulation will be present in the converter's output data.

CAP PIN

The voltage on the CAP pin is the output of the reference buffer. This pin should be bypassed with a 0.1 μ F ceramic capacitor in parallel with a 2.2 μ F tantalum capacitor. While both capacitors should be physically close to the ADS7811, it is very important that the ceramic capacitor be placed as close as possible.

The CAP pin connects to the internal reference buffer and directly to the binary weighted capacitor array of the converter. Thus, the signal at the CAP pin has high-frequency glitches which occur at each bit decision. For this reason, the CAP voltage should not be used to provide a reference voltage for external circuitry.

LAYOUT

The layout of the ADS7811 and accompanying components will be critical for optimum performance. Use of an analog ground plane is essential. Use of +5V and -5V power planes is not critical as long as the supplies are well bypassed, and the traces connecting +5V and -5V to the power connector are not too long or too thin.

The two +V_S power pins of the ADS7811 must be tied together. The voltage source for these pins should also power the input buffer and the 74HC00 shown in Figure 1. This supply should separate from the positive +5V supply for the system's digital logic

Three ground pins are present on the ADS7811: pin 2, pin 5, and pin 14. These should all be tied to the analog ground plane. The analog ground plane should extend underneath all analog signal conditioning components and up to the 74HC574s (or equivalent components) shown in Figure 1. The 74HC574s should not be located more than several inches from the ADS7811.

The ground for the 74HC574s should be connected to the digital ground. The analog ground plane should extend up to the 74HC574s but should be kept at least 1/4" (6mm) distant from the digital ground plane (if present). The analog and digital grounds planes should not overlap at any point.

INTERMEDIATE LATCHES

The 74HC574s shown in Figure 1 isolate the ADS7811 from digital signals on a microprocessor, digital signal processor (DSP), or microcontroller bus. This is necessary because of the precision needed within the ADS7811. The weight of a single LSB in the ADS7811 is 76 μ V, and the comparator must be able to resolve differences in voltage to this level. External digital signals which transition during the conversion can easily couple onto the substrate and produce voltages larger than this.

In place of the 74HC574s, it might be possible to use a FIFO or similar type of memory device. For many systems, it may be difficult to go directly from the ADS7811 into a microcontroller or DSP even if the ADS7811 is not connected to shared bus. The reason for this is that the outputs are active only during the acquisition period.

SIGNAL CONDITIONING

The ADS7811 input essentially consists of a switch and a capacitor. In the acquisition or sample mode, the switch is closed and the input signal drives the capacitor directly. When a conversion is started, the switch is opened capturing the input signal at that moment. This voltage is held on the capacitor for the remainder of the conversion.

While this provides for a wide bandwidth sample and hold function and results in excellent AC performance, this architecture requires a high bandwidth, precision op amp to drive the analog input. The op amp and configuration shown in Figure 1 is highly recommended. The amplifier should be placed within 1 to 2 inches (25 to 50mm) of the ADS7811, and the layout guidelines in the OPA628 data sheet should be strictly followed.

Revision History

DATE	REVISION	PAGE	SECTION	DESCRIPTION
11/06	A	—	Entire Document	Updated document format to current standard; some page layout changed.
		3	Electrical Characteristics	Changed Integral Linearity Error from max value ± 4 to ± 6 .
				Changed Total Harmonic Distortion max value from -96 to -94 .
				Changed Signal-to-(Noise+Distortion) min value from 84 to 82 .
			Changed Signal-to-Noise min value from 84 to 82 .	

NOTE: Page numbers for previous revisions may differ from page numbers in the current version.

PACKAGING INFORMATION

Orderable Device	Status (1)	Package Type	Package Drawing	Pins	Package Qty	Eco Plan (2)	Lead finish/ Ball material (6)	MSL Peak Temp (3)	Op Temp (°C)	Device Marking (4/5)	Samples
ADS7811U	NRND	SOIC	DW	28	20	RoHS & Green	Call TI	Level-3-260C-168 HR	-25 to 85	ADS7811U	

(1) The marketing status values are defined as follows:

ACTIVE: Product device recommended for new designs.

LIFEBUY: TI has announced that the device will be discontinued, and a lifetime-buy period is in effect.

NRND: Not recommended for new designs. Device is in production to support existing customers, but TI does not recommend using this part in a new design.

PREVIEW: Device has been announced but is not in production. Samples may or may not be available.

OBsolete: TI has discontinued the production of the device.

(2) **RoHS:** TI defines "RoHS" to mean semiconductor products that are compliant with the current EU RoHS requirements for all 10 RoHS substances, including the requirement that RoHS substance do not exceed 0.1% by weight in homogeneous materials. Where designed to be soldered at high temperatures, "RoHS" products are suitable for use in specified lead-free processes. TI may reference these types of products as "Pb-Free".

RoHS Exempt: TI defines "RoHS Exempt" to mean products that contain lead but are compliant with EU RoHS pursuant to a specific EU RoHS exemption.

Green: TI defines "Green" to mean the content of Chlorine (Cl) and Bromine (Br) based flame retardants meet JS709B low halogen requirements of <=1000ppm threshold. Antimony trioxide based flame retardants must also meet the <=1000ppm threshold requirement.

(3) MSL, Peak Temp. - The Moisture Sensitivity Level rating according to the JEDEC industry standard classifications, and peak solder temperature.

(4) There may be additional marking, which relates to the logo, the lot trace code information, or the environmental category on the device.

(5) Multiple Device Markings will be inside parentheses. Only one Device Marking contained in parentheses and separated by a "-" will appear on a device. If a line is indented then it is a continuation of the previous line and the two combined represent the entire Device Marking for that device.

(6) Lead finish/Ball material - Orderable Devices may have multiple material finish options. Finish options are separated by a vertical ruled line. Lead finish/Ball material values may wrap to two lines if the finish value exceeds the maximum column width.

Important Information and Disclaimer:The information provided on this page represents TI's knowledge and belief as of the date that it is provided. TI bases its knowledge and belief on information provided by third parties, and makes no representation or warranty as to the accuracy of such information. Efforts are underway to better integrate information from third parties. TI has taken and continues to take reasonable steps to provide representative and accurate information but may not have conducted destructive testing or chemical analysis on incoming materials and chemicals. TI and TI suppliers consider certain information to be proprietary, and thus CAS numbers and other limited information may not be available for release.

In no event shall TI's liability arising out of such information exceed the total purchase price of the TI part(s) at issue in this document sold by TI to Customer on an annual basis.

TUBE

*All dimensions are nominal

Device	Package Name	Package Type	Pins	SPQ	L (mm)	W (mm)	T (μm)	B (mm)
ADS7811U	DW	SOIC	28	20	507	12.83	5080	6.6

DW (R-PDSO-G28)

PLASTIC SMALL OUTLINE

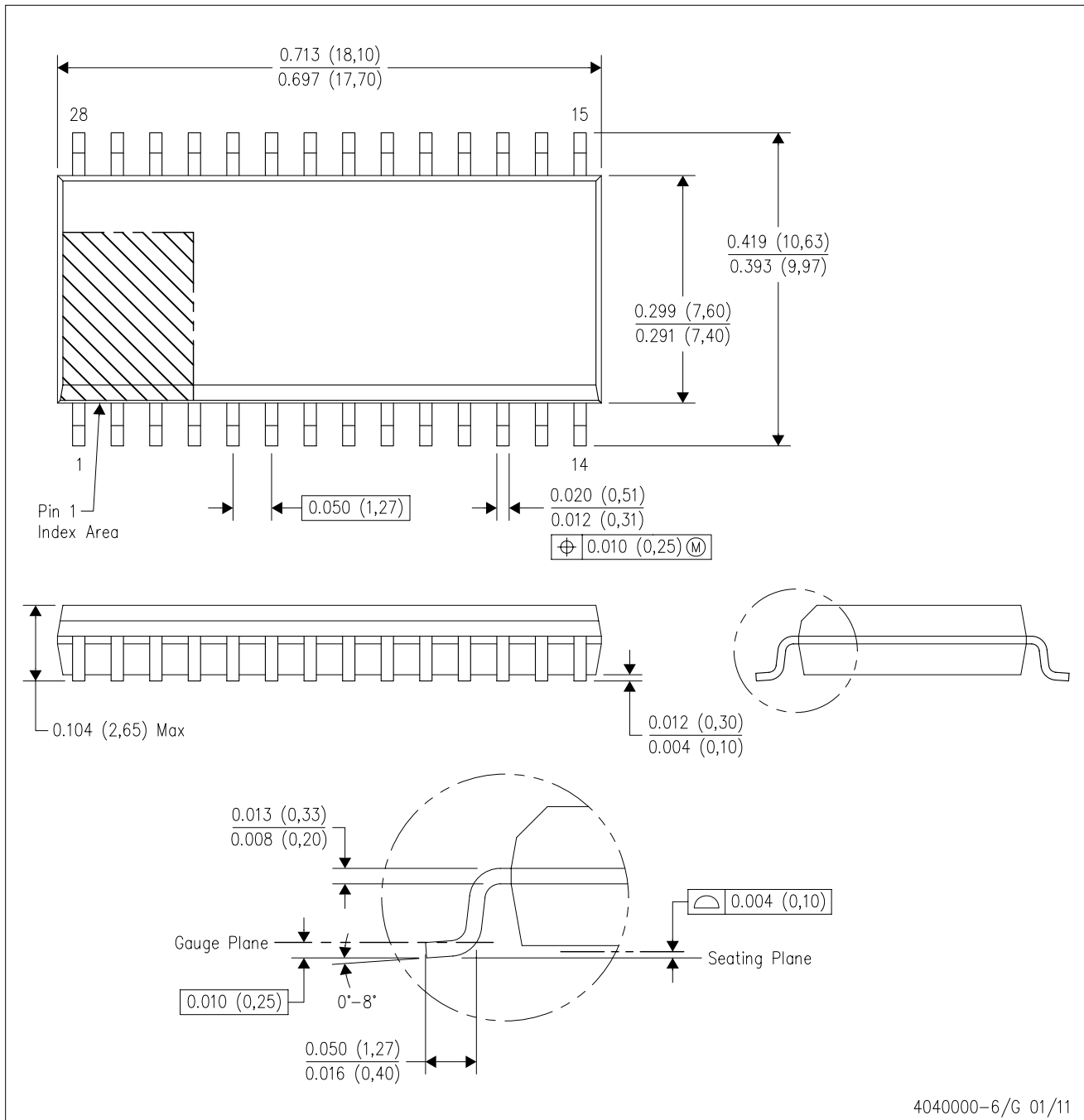

4040000-6/G 01/11

- NOTES:
- All linear dimensions are in inches (millimeters). Dimensioning and tolerancing per ASME Y14.5M-1994.
 - This drawing is subject to change without notice.
 - Body dimensions do not include mold flash or protrusion not to exceed 0.006 (0,15).
 - Falls within JEDEC MS-013 variation AE.

DW (R-PDSO-G28)

PLASTIC SMALL OUTLINE

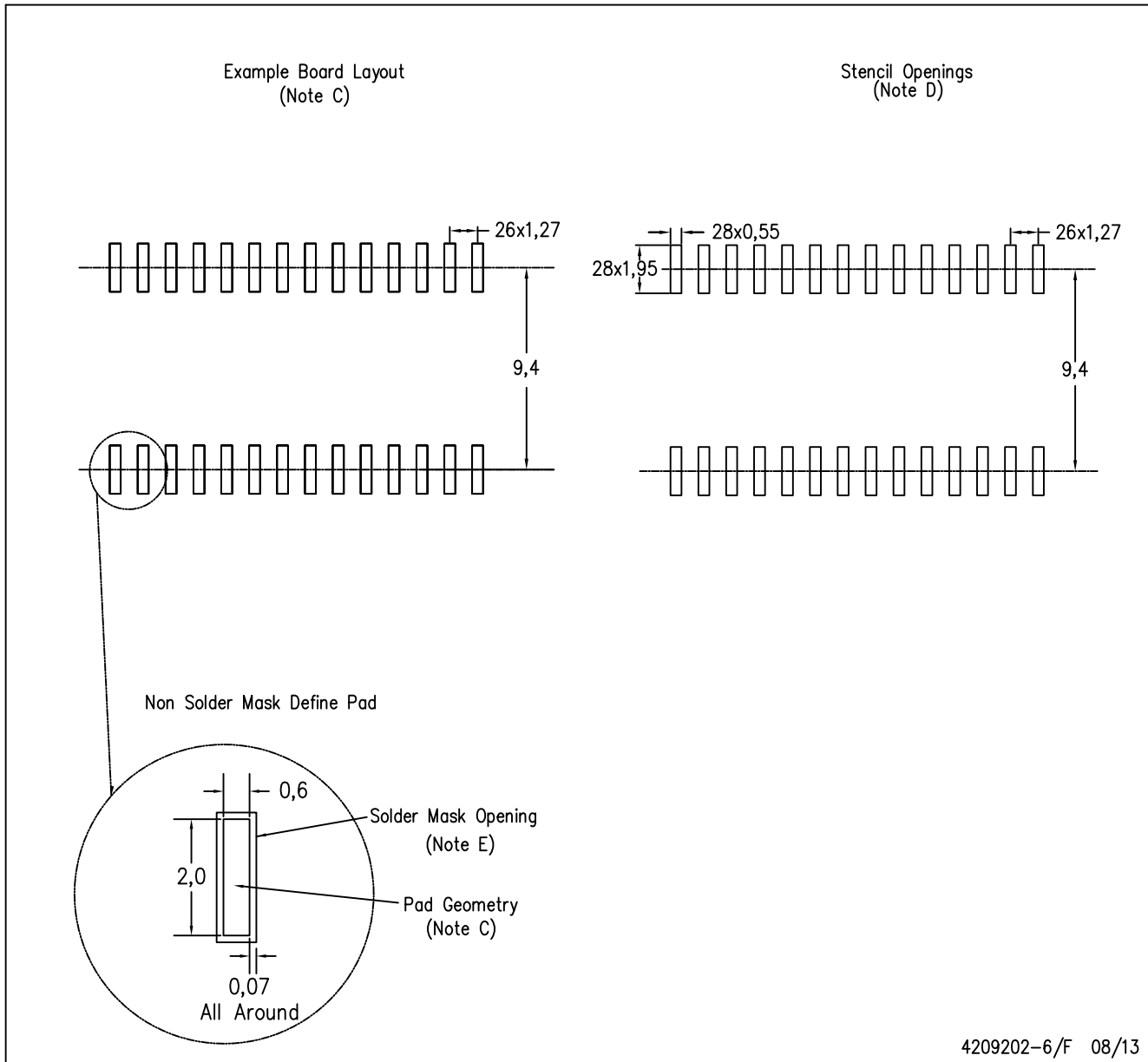

4209202-6/F 08/13

- NOTES:
- A. All linear dimensions are in millimeters.
 - B. This drawing is subject to change without notice.
 - C. Refer to IPC7351 for alternate board design.
 - D. Laser cutting apertures with trapezoidal walls and also rounding corners will offer better paste release. Customers should contact their board assembly site for stencil design recommendations. Refer to IPC-7525
 - E. Customers should contact their board fabrication site for solder mask tolerances between and around signal pads.

IMPORTANT NOTICE AND DISCLAIMER

TI PROVIDES TECHNICAL AND RELIABILITY DATA (INCLUDING DATA SHEETS), DESIGN RESOURCES (INCLUDING REFERENCE DESIGNS), APPLICATION OR OTHER DESIGN ADVICE, WEB TOOLS, SAFETY INFORMATION, AND OTHER RESOURCES "AS IS" AND WITH ALL FAULTS, AND DISCLAIMS ALL WARRANTIES, EXPRESS AND IMPLIED, INCLUDING WITHOUT LIMITATION ANY IMPLIED WARRANTIES OF MERCHANTABILITY, FITNESS FOR A PARTICULAR PURPOSE OR NON-INFRINGEMENT OF THIRD PARTY INTELLECTUAL PROPERTY RIGHTS.

These resources are intended for skilled developers designing with TI products. You are solely responsible for (1) selecting the appropriate TI products for your application, (2) designing, validating and testing your application, and (3) ensuring your application meets applicable standards, and any other safety, security, regulatory or other requirements.

These resources are subject to change without notice. TI grants you permission to use these resources only for development of an application that uses the TI products described in the resource. Other reproduction and display of these resources is prohibited. No license is granted to any other TI intellectual property right or to any third party intellectual property right. TI disclaims responsibility for, and you will fully indemnify TI and its representatives against, any claims, damages, costs, losses, and liabilities arising out of your use of these resources.

TI's products are provided subject to [TI's Terms of Sale](#) or other applicable terms available either on ti.com or provided in conjunction with such TI products. TI's provision of these resources does not expand or otherwise alter TI's applicable warranties or warranty disclaimers for TI products.

TI objects to and rejects any additional or different terms you may have proposed.

Mailing Address: Texas Instruments, Post Office Box 655303, Dallas, Texas 75265
Copyright © 2022, Texas Instruments Incorporated