



DIN power female connector low profile



General information

Design	IEC 60603-2	types: F & G low profile female
No. of contacts	max. 48 for type F	max. 64 for type G
Contact spacing	5,08mm longitudinal	3,81 mm between rows for type F
		3,81mm between rows z, b & d for type G
		5,08mm between rows d & f for type G
Test voltage	1550V contact/contact	2500V contact/ground
Contact resistance	max. 15mOhm for solder-termination	
Insulation resistance	min. 10 ¹⁰ Ohm	
Working current	6A at 20°C (see derating diagram) for unmounted connector, limitations may occur due to PCB material	
Temperature range	-55°C ... +125°C	
	-40°C ... +105°C for press-in connectors (due to limitations of PCB-material)	
Termination technology	press-in, solder pins	
Clearance	min. 1,6 mm	
Creepage	min. 3,0 mm	
Insertion and withdrawal force	32-pole max. 50N	64-pole max. 100N
	48-pole max. 75N	
Mating cycles	acc. to performance level, see table below	
UL file	E102079	
RoHS - compliant	Yes	
Leadfree	Yes	
Hot plugging	No	

Insulator material

Material	PBT (thermoplastics, glass fiber reinforcement 30%)
Color	RAL 7032 (grey)
UL classification	UL 94-V0
Material group acc. IEC 60664-1	IIIa (175 ≤ CTI < 400)
NFF classification	I3, F4

Contact material

Contact material	Copper alloy
Plating termination zone	Sn over Ni for solder, Ni for press-in
Plating contact zone	acc. to performance level, see table below

performance level	mating cycles acc. to IEC 60603-2	plating contact zone
1	500	<i>Au over PdNi over Ni</i>
2	400	<i>Au over PdNi over Ni</i>
Au1	500	Au over Ni

Standard plating options highlighted in *italic*, other plating options are available on request.

Derating diagram acc. to IEC 60512-5 (Current carrying capacity)

The current carrying capacity is limited by maximum temperature of materials for inserts and contacts including terminals.

The current capacity curve is valid for continuous, non interrupted current loaded contacts of connectors when simultaneous power on all contacts is given, without exceeding the maximum temperature.

Control and test procedures according to DIN IEC 60512-5

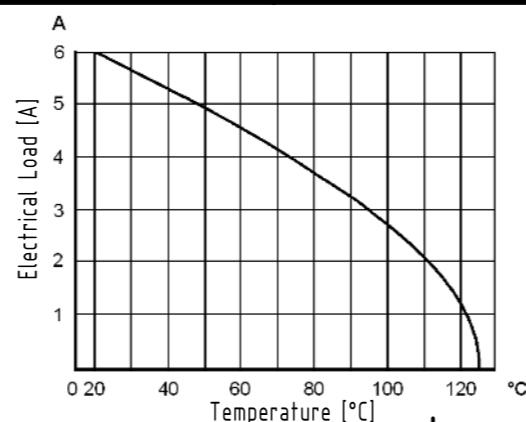

Recommended configuration of plated through holes for press-in termination

In addition to the hot-air-level (HAL), other PCB surfaces are getting more important. Due to their different properties - such as mechanical strength and coefficient of friction - we recommend the following configuration of PCB through holes.

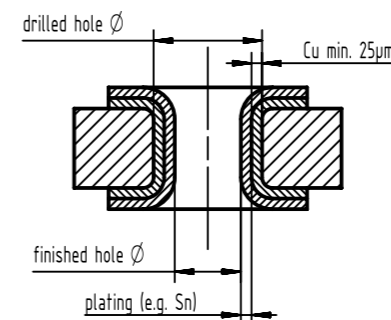

Plating	Drilled hole Ø	Plated hole Ø
Tin plated PCB (HAL) acc. to EN 60352-5	1,15±0,025 mm	max. 15 µm
		0,94 - 1,09 mm
Chemical tin plated PCB	1,15±0,025 mm	min. 0,8µm
		1,00 - 1,10 mm
Gold /Nickel plated PCB	1,15±0,025 mm	3 - 7 µm
		0,05 - 0,12 µm
Silver plated PCB	1,15±0,025 mm	0,1 - 0,3 µm
		1,00 - 1,10 mm
Copper plated PCB (OSP)	1,15±0,025 mm	
		1,00 - 1,10 mm

Assembly instructions

It is highly recommended to use HARTING press-in tools to ensure a reliable press-in process. Please refer to the catalogue for tools, machines and further information about the press-in process.

Soldering instructions

The connectors should be protected when being soldered in a dip, flow or film soldering baths. Otherwise, they might become contaminated as a result of soldering operations or deformed as a result of overheating.

(1) For prototypes and short runs protect the connectors with an industrial adhesive tape, e.g. Tesaband 4331 (www.tesa.de). Cover the underside of the connector moulding and the adjacent parts of the pcb as well as the open sides of the connector. This will prevent heat and gases of the soldering apparatus from damaging the connector. About 140 + 5 mm of the tape should suffice.

(2) For large series a jig is recommended. Its protective cover with a fast action mechanical locking device shields the connectors from gas and heat generated by the soldering apparatus. As an additional protection a foil can be used for covering the parts that should not be soldered.

Cross section of solder terminations

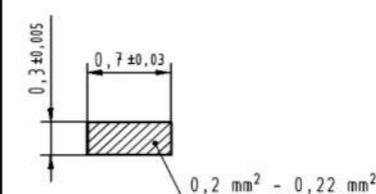

	All Dimensions in mm Original Size DIN A3	Scale 1:1	Free size tol.	Ref. Sub.
	All rights reserved Department EL PD	Created by STORCK	Inspected by TADJE	Standardisation HOFFMANN
HARTING Electronics GmbH D-32339 Espelkamp	Title DIN power female connector low profile		Date 2020-03-12	State Final Release
	Type DS	Number 09062100006	Doc-Key / ECM-Nr. 100580658/UGD/000/B 500000164769	Rev. B
				Page 1/1