

APPROVED: _____
 DATE: _____ TITLE: _____

Rev	AWO #	Description	Date	Appr
-		RELEASED	8/16/21	

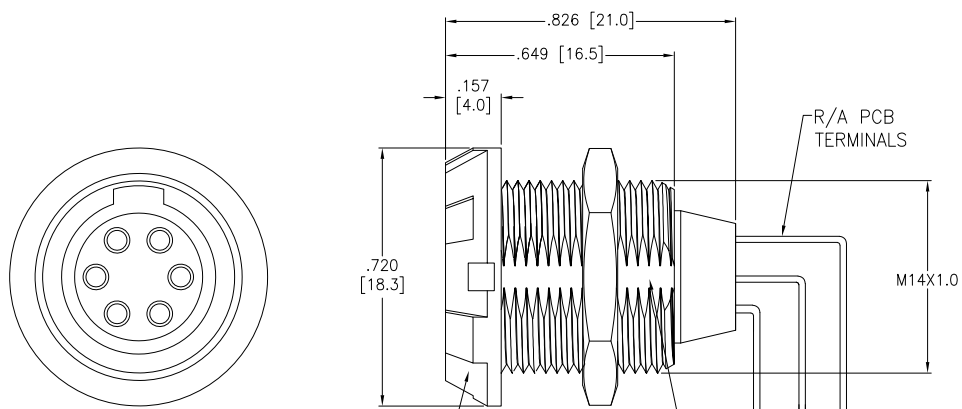

MMI-P1SRXXXPRXX

SIZE
1

ALIGNMENT KEY	
G	= 0°
A	= 40°
B	= 60°
C	= 80°

BODY COLOR	
B	= BLACK
G	= GRAY

FRONT NUT COLOR	
B	= BLACK
G	= GRAY
GR	= GREEN
Y	= YELLOW
R	= RED

OF POSITIONS

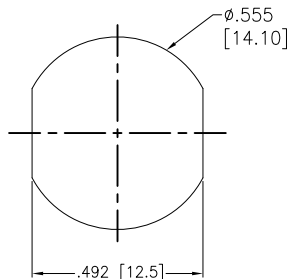

RECOMMENDED
 PANEL CUT-OUT
 (Rear Panel mounting)

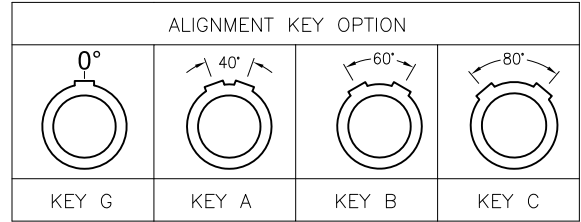

Configuration	Size 1									
	2 Pin	3 Pin	4 Pin	5 Pin	6 Pin	7 Pin	8 Pin	9 Pin	10 Pin	14 Pin
Diameter of Pin	1.3	1.3	0.9	0.9	0.7	0.7	0.7	0.5	0.5	0.5
Testing Voltage	1200V	1200V	1200V	1200V	1000V	1000V	1000V	800V	800V	800V
Working Voltage	300V	300V	250V	250V	200V	200V	200V	200V	200V	200V
Rated Current / Pin	20A	12A	10A	9A	8A	7A	6A	4A	4A	4A

SPECIFICATIONS:
 Material:
 Housing PC
 Insulator: PPS
 Terminal: Brass, Gold Plated
 Electrical:
 Voltage Rating: See chart
 Current Rating: See chart
 Dielectric withstanding voltage: See chart
 Electrical Life: 1,000 Cycles min.
 Temperature Rating:
 Operating temperature: -55°C to +118°C
 Environmental:
 IP50 Protection (Mated Condition)
 Lead free, RoHS compliant



SEE SHT 2 OF 2 FOR RECOMMENDED
 PCB LAYOUT

UNLESS OTHERWISE SPECIFIED ALL DIMENSIONS ARE INCHES [MM] TOLERANCES: EXCEPT AS NOTED INCHES HOLES		
.X ± .10	Ø.X ± .10	
.XX ± .020	Ø.XX ± .015	
.XXX ± .015	Ø.XXX ± .010	
APPROVALS		DATE
DRAWN	SS	8/16/21
CHECKED	SS	8/16/21
APPROVED		

ADAM TECH 909 Rahway Avenue,
 Union, NJ 07083
 Phone: 908-687-5000
 Fax: 908-687-5710

TITLE: PUSH-PULL SOCKET, VERTICAL, SIZE 1, PLASTIC
 BODY, REAR PANEL MOUNT, R/A PCB THROUGH HOLE

SIZE X	PART NO. MMI-P1SRXXXPRXX	REV. -
REF: SXXXXXX	SCALE: NTS	SHEET 1 OF 2

6 5 4 3 2 1

6 5 4 3 2 1

D

D

C

C

B

B

A

A

APPROVED: _____
 DATE: _____ TITLE: _____

Rev	AWO #	Description	Date	Appr
-		RELEASED	8/16/21	

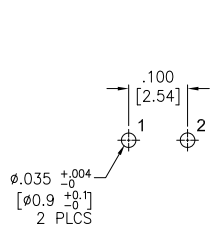

2 PIN

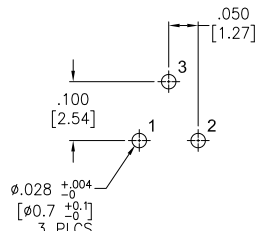

3 PIN

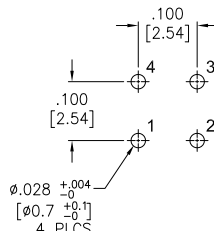

4 PIN

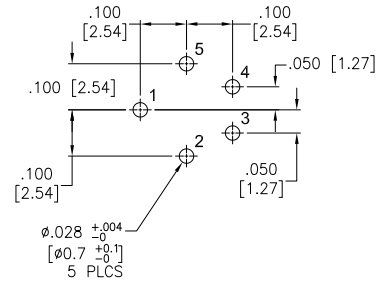

5 PIN

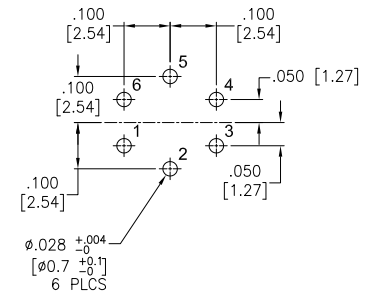

6 PIN

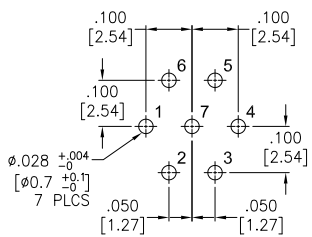

7 PIN

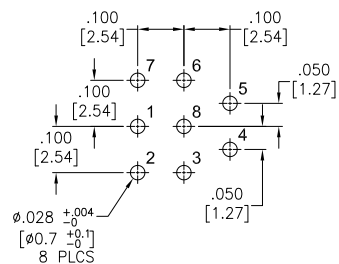

8 PIN

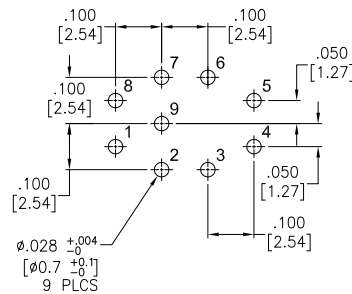

9 PIN

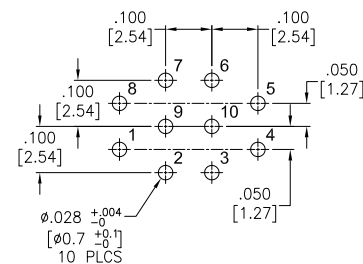

10 PIN

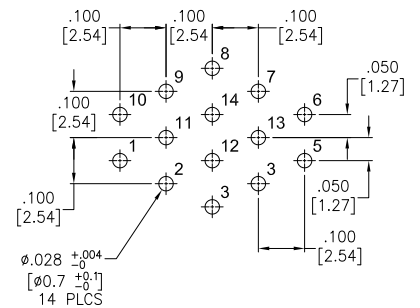

14 PIN

UNLESS OTHERWISE SPECIFIED
 ALL DIMENSIONS ARE INCHES [MM]
 TOLERANCES: EXCEPT AS NOTED
 INCHES HOLES

.X	± .10	Ø.X	± .10
.XX	± .020	Ø.XX	± .015
.XXX	± .015	Ø.XXX	± .010

APPROVALS		DATE
DRAWN	SS	8/16/21
CHECKED	SS	8/16/21
APPROVED		

ADAM TECH 909 Rahway Avenue,
 Union, NJ 07083
 Phone: 908-687-5000
 Fax: 908-687-5710

TITLE: PUSH-PULL SOCKET, VERTICAL, SIZE 1, PLASTIC BODY, REAR PANEL MOUNT, R/A PCB THROUGH HOLE

SIZE X	PART NO. MMI-P1SRXXXPRXX	REV. -
REF: SXXXXX	SCALE: NTS	SHEET 2 OF 2