

FIG 1
SFM-105-02-X-SH SHOWN

- NOTES:
1. Ⓢ REPRESENTS A CRITICAL DIMENSION.
 2. MAXIMUM BURR ALLOWANCE: .0015[0.038].
 3. MINIMUM PUSHOUT FORCE: .5 LB.
 4. NOT RECOMMENDED FOR INVERTED REFLOW SOLDER.
 5. NOTE DELETED.
 6. NOTE DELETED.
 7. ORDERS WILL BE PACKAGED ACCORDING TO THE SAMTEC PACKAGING EFFICIENCY STANDARDS (SPES) FOUND ON WWW.SAMTEC.COM.
 8. ATTACH LABEL -4x2 TO EACH REEL.

SFM-1XX-XX-X-XH-XR

No OF POSITIONS
-05 THRU -30(PER ROW)

LEAD STYLE
-02

PACKAGE
-TR: TAPE & REEL
(SEE NOTE 7 & 8)
-FR: FULL REEL QTY TAPE
& REEL (SEE NOTE 7 & 8)

ROW SPECIFICATION
-SH: SINGLE HORIZONTAL
-DH: DOUBLE HORIZONTAL

PLATING SPECIFICATION
-L: 10μ" SELECTIVE GOLD IN CONTACT
AREA, MATTE TIN ON TAIL
-S: 30μ" SELECTIVE GOLD IN CONTACT
AREA, MATTE TIN ON TAIL

(* = NOT TOOLED)

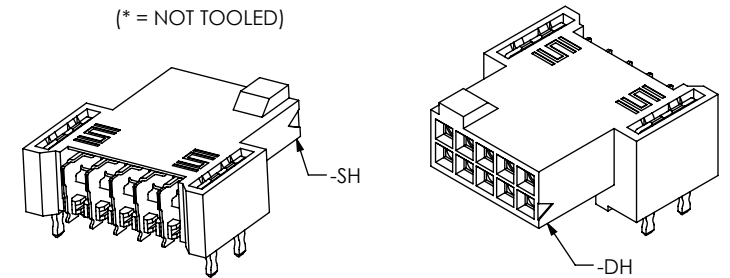

TABLE 2

ROW SPEC	"A"
-SH	.123 [3.12]
-DH	.173 [4.39]

TABLE 1

No. OF POS	⌒	—
-05 THRU -30	.004[0.10]	.004[0.10]
*-31 THRU *-50	.006[0.15]	.006[0.15]

(* = NOT TOOLED)

UNLESS OTHERWISE SPECIFIED, DIMENSIONS ARE IN INCHES.

TOLERANCES ARE:
DECIMALS ANGLES
.XX: ±.01[0.3] 2°
.XXX: ±.005[0.13]
.XXXX: ±.0020[0.051]

PROPRIETARY NOTE
THIS DOCUMENT CONTAINS CONFIDENTIAL AND PROPRIETARY INFORMATION AND ALL DESIGN, MANUFACTURING, REPRODUCTION, USE, PATENT RIGHTS AND SALES RIGHTS ARE EXPRESSLY RESERVED BY SAMTEC, INC. THIS DOCUMENT SHALL NOT BE DISCLOSED, IN WHOLE OR PART, TO ANY UNAUTHORIZED PERSON OR ENTITY NOR REPRODUCED, TRANSFERRED OR INCORPORATED IN ANY OTHER PROJECT IN ANY MANNER WITHOUT THE EXPRESS WRITTEN CONSENT OF SAMTEC, INC.

MATERIAL: DO NOT SCALE DRAWING SHEET SCALE: 6:1
INSULATOR: VECTRA E130i UL 94V-0, COLOR: BLACK
CONTACT: PHOS BRONZE

DESCRIPTION:
.050 x .050 SOCKET STRIP ASSEMBLY

DWG. NO. SFM-1XX-XX-X-XH-XR

BY: VICKY Z 11/22/2010 SHEET 1 OF 3

F:\DWG\MISC\MKTG\SFM-1XX-XX-X-XH-XR-MKT.SLDDRW



520 PARK EAST BLVD, NEW ALBANY, IN 47150
PHONE: 812-944-6733 FAX: 812-948-5047
e-Mail info@SAMTEC.com code 55322

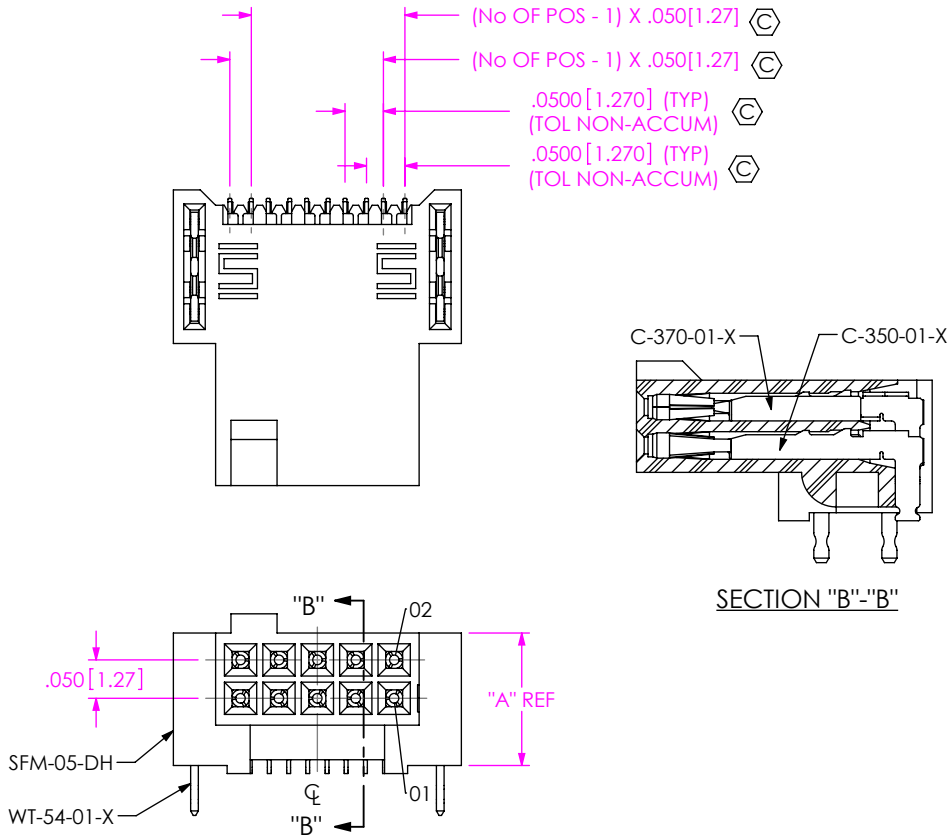
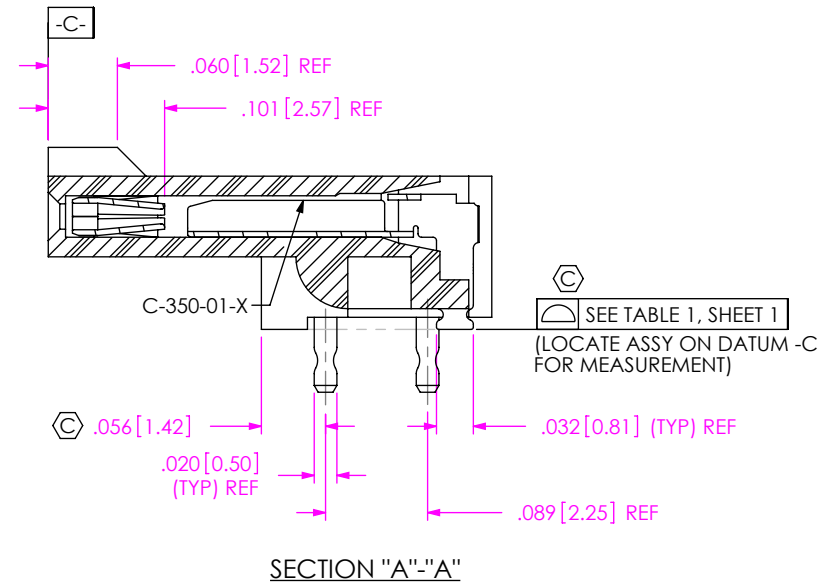

FIG 2
 SFM-105-02-X-DH SHOWN
 (DIFFERENT AS SHOWN, OTHERWISE SAME AS FIG 1)



* PROPRIETARY NOTE *
 THIS DOCUMENT CONTAINS CONFIDENTIAL AND PROPRIETARY INFORMATION AND ALL DESIGN, MANUFACTURING, REPRODUCTION, USE, PATENT RIGHTS AND SALES RIGHTS ARE EXPRESSLY RESERVED BY SAMTEC, INC. THIS DOCUMENT SHALL NOT BE DISCLOSED, IN WHOLE OR PART, TO ANY UNAUTHORIZED PERSON OR ENTITY NOR REPRODUCED, TRANSFERRED OR INCORPORATED IN ANY OTHER PROJECT IN ANY MANNER WITHOUT THE EXPRESS WRITTEN CONSENT OF SAMTEC, INC.

DO NOT SCALE DRAWING

SHEET SCALE: 4:1

samtec
 520 PARK EAST BLVD. NEW ALBANY, IN 47150
 PHONE: 812-944-6733 FAX: 812-948-5047
 e-Mail info@SAMTEC.com code 55322

DESCRIPTION:
 .050 x .050 SOCKET STRIP ASSEMBLY

DWG. NO.
SFM-1XX-XX-X-XH-XR

BY: VICKY Z 11/22/2010 SHEET 2 OF 3

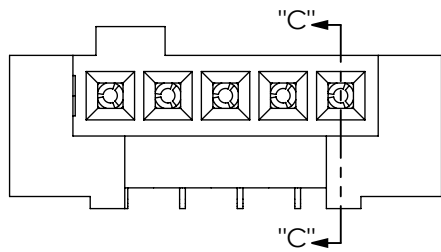

IN-PROCESS 1
FILL C-350-01-X
(FOR -SH ONLY)

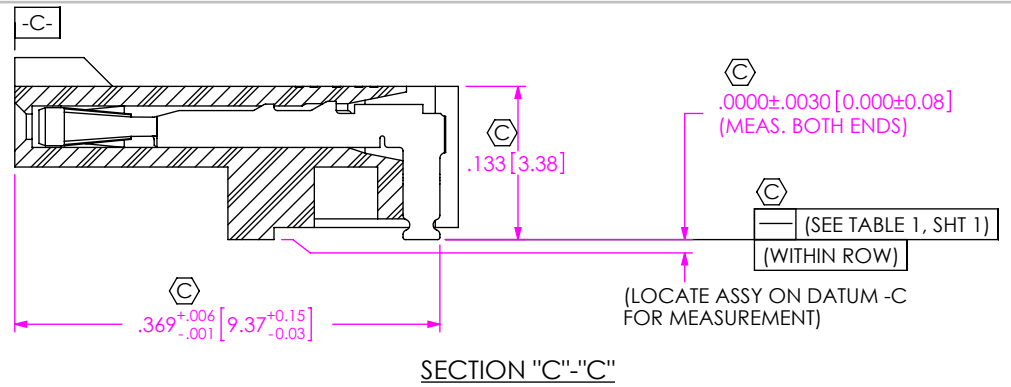

SECTION "C"-"C"

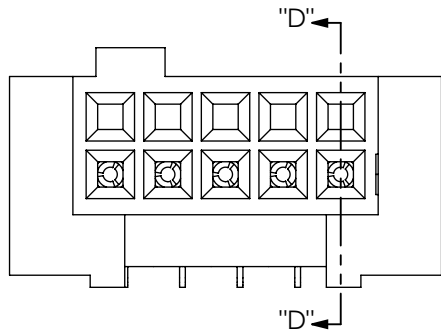

IN-PROCESS 1
FILL C-350-01-X
(FOR -DH ONLY)

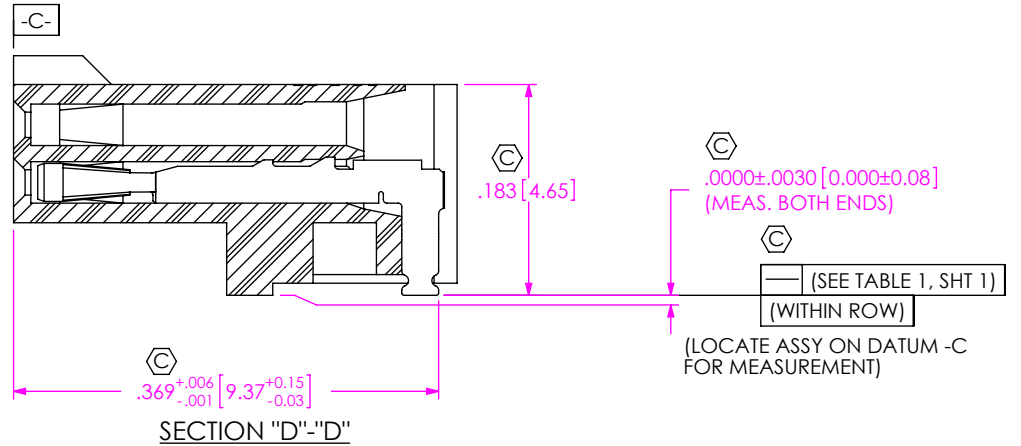

SECTION "D"-"D"

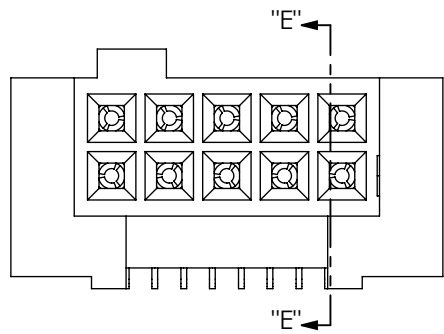

IN-PROCESS 2
FILL C-370-01-X
(FOR -DH ONLY)

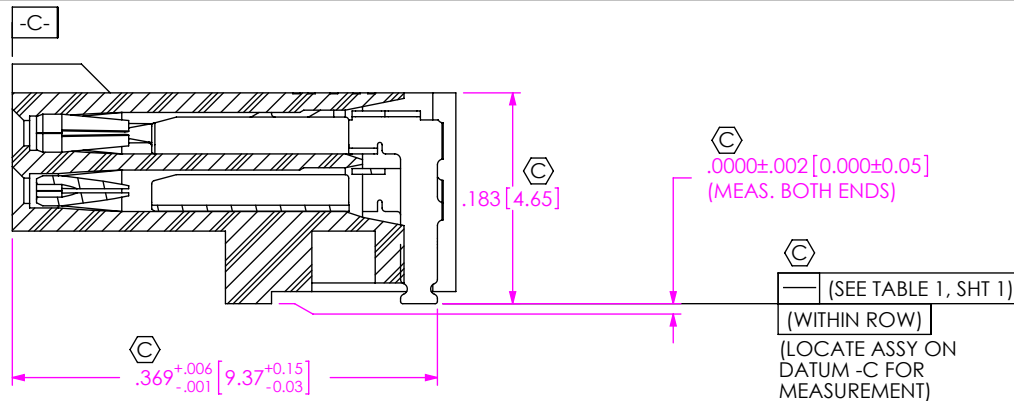

SECTION "E"-"E"

PROPRIETARY NOTE
THIS DOCUMENT CONTAINS CONFIDENTIAL AND PROPRIETARY INFORMATION AND ALL DESIGN, MANUFACTURING, REPRODUCTION, USE, PATENT RIGHTS AND SALES RIGHTS ARE EXPRESSLY RESERVED BY SAMTEC, INC. THIS DOCUMENT SHALL NOT BE DISCLOSED, IN WHOLE OR PART, TO ANY UNAUTHORIZED PERSON OR ENTITY NOR REPRODUCED, TRANSFERRED OR INCORPORATED IN ANY OTHER PROJECT IN ANY MANNER WITHOUT THE EXPRESS WRITTEN CONSENT OF SAMTEC, INC.

DO NOT SCALE DRAWING

SHEET SCALE: 6:1



520 PARK EAST BLVD. NEW ALBANY, IN 47150
PHONE: 812-944-6733 FAX: 812-948-5047
e-Mail info@SAMTEC.com code 55322

DESCRIPTION: .050 x .050 SOCKET STRIP ASSEMBLY

DWG. NO. SFM-1XX-XX-X-XH-XR

BY: VICKY Z 11/22/2010 SHEET 3 OF 3