

REVISIONS					
REV	DATE	DESCRIPTION	BY	CHK	APP'D
D2	03AUG2022	REVISED PER ECR-21-117154	SKR	VS	

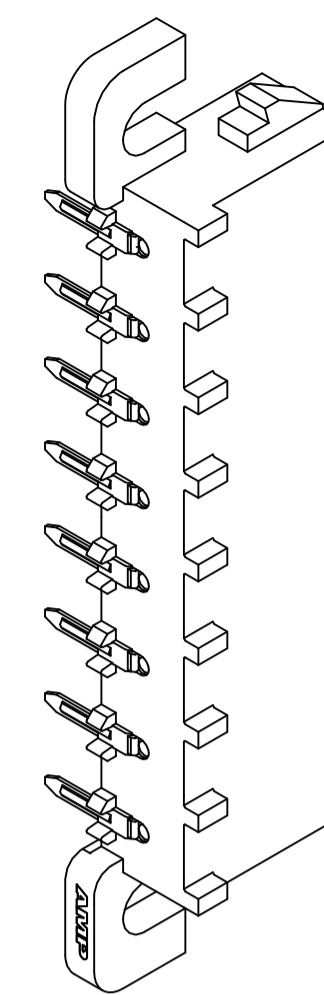

3-DIMENSIONAL MODEL NTS

- 1 PARTS COMPLY WITH AMP SOLDERABILITY SPECIFICATION 109-11-5.
- 2 TOLERANCE NON-CUMULATIVE.
- 3 0.00076 GOLD OVER 0.00127 MIN NICKEL WITH MATTE TIN LEAD ON SOLDER TAIL.
- 4 CIRCUIT IDENTIFICATION CHARACTERS ARE ADJACENT TO THE INDICATED CAVITIES, BUT LOCATION AND ORIENTATION MAY DIFFER FROM PRINT.
- 5 0.00076 GOLD OVER 0.00127 MIN NICKEL WITH MATTE TIN ON SOLDER TAIL.
- 6 SUPERSEDED BY 3-643236-0
- 7 DIMENSION SHOWN REPRESENT PRODUCT IN DRY CONDITION. ADDITIONAL 2% GROWTH DUE TO END USE LOCATION MOISTURE ABSORPTION MAY OCCUR AND SHOULD BE ACCOUNTED FOR.

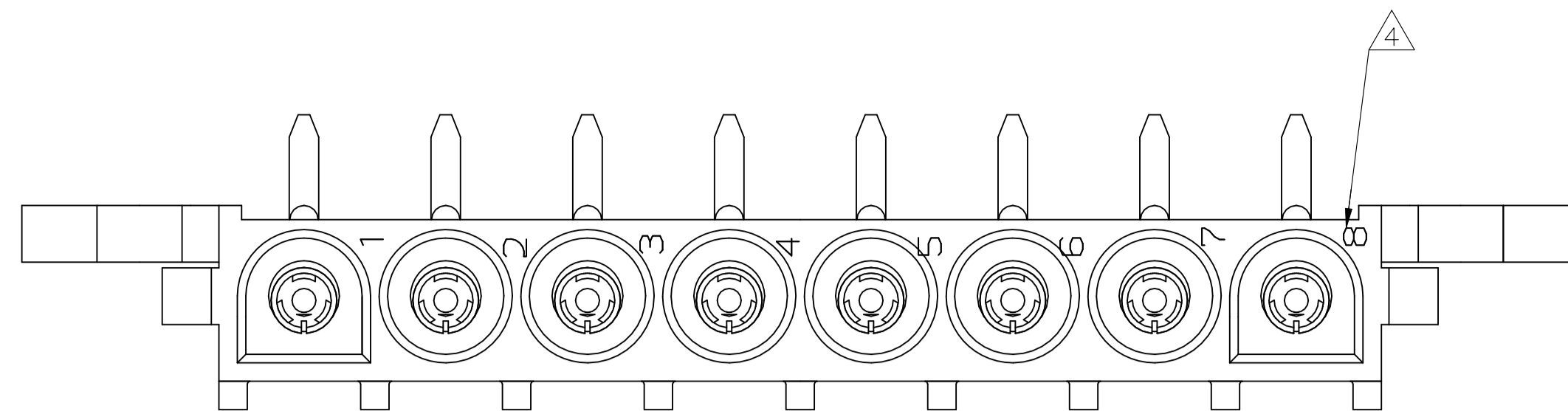
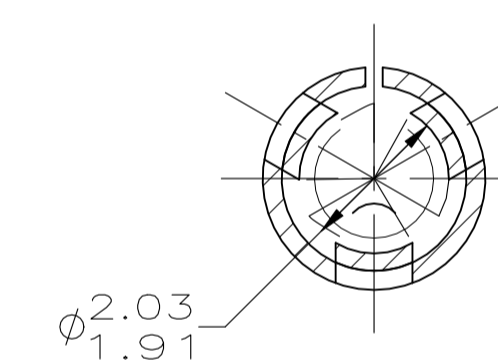
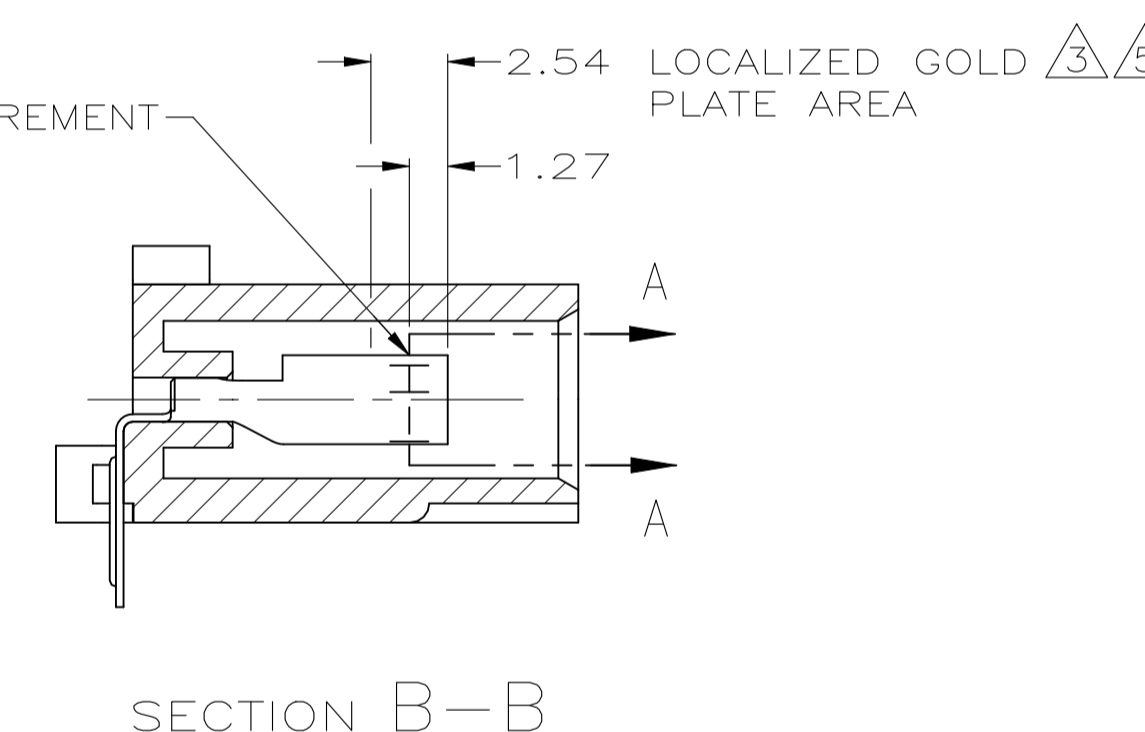
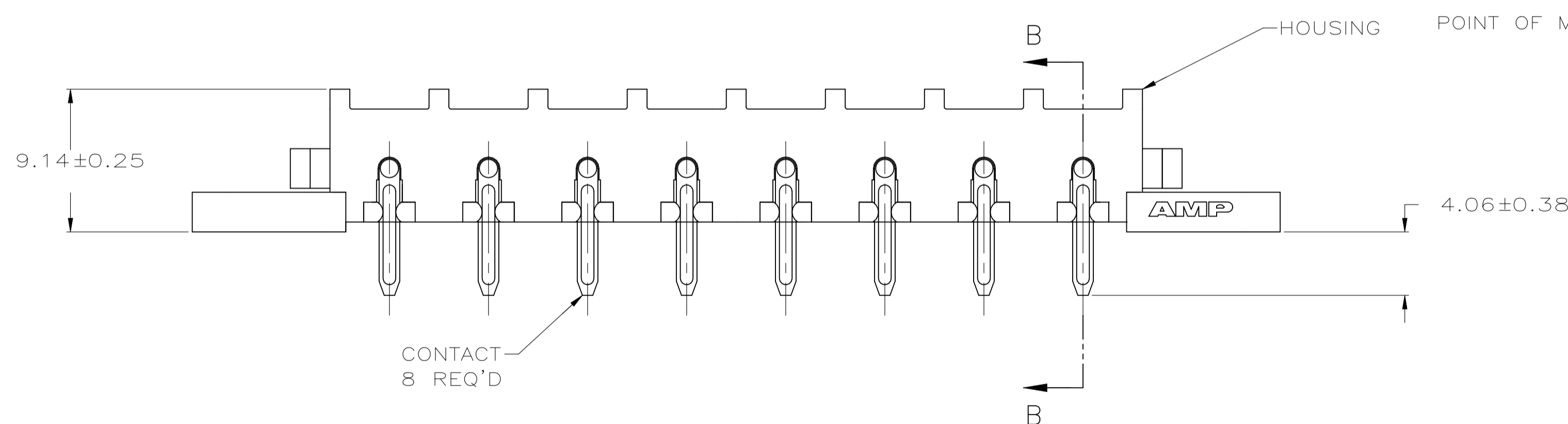
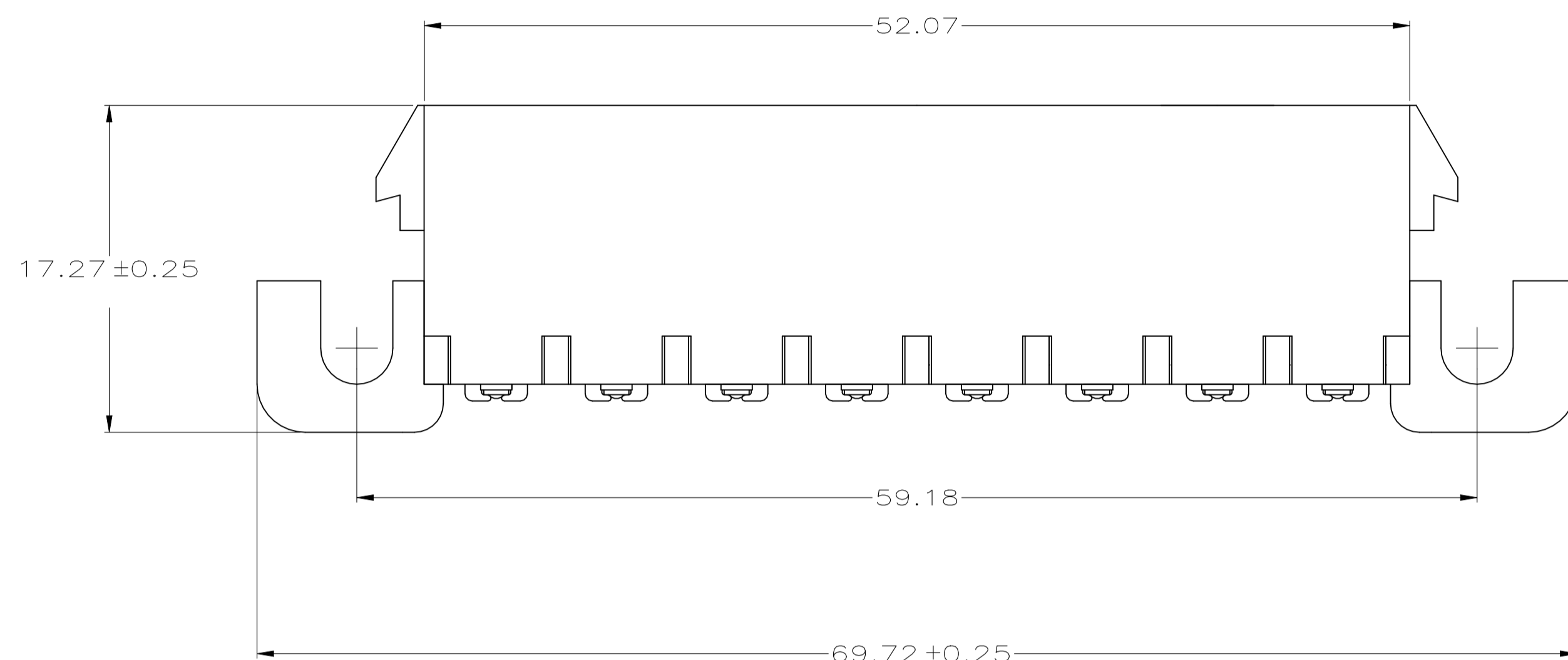

SECTION A-A  
SCALE 10:1

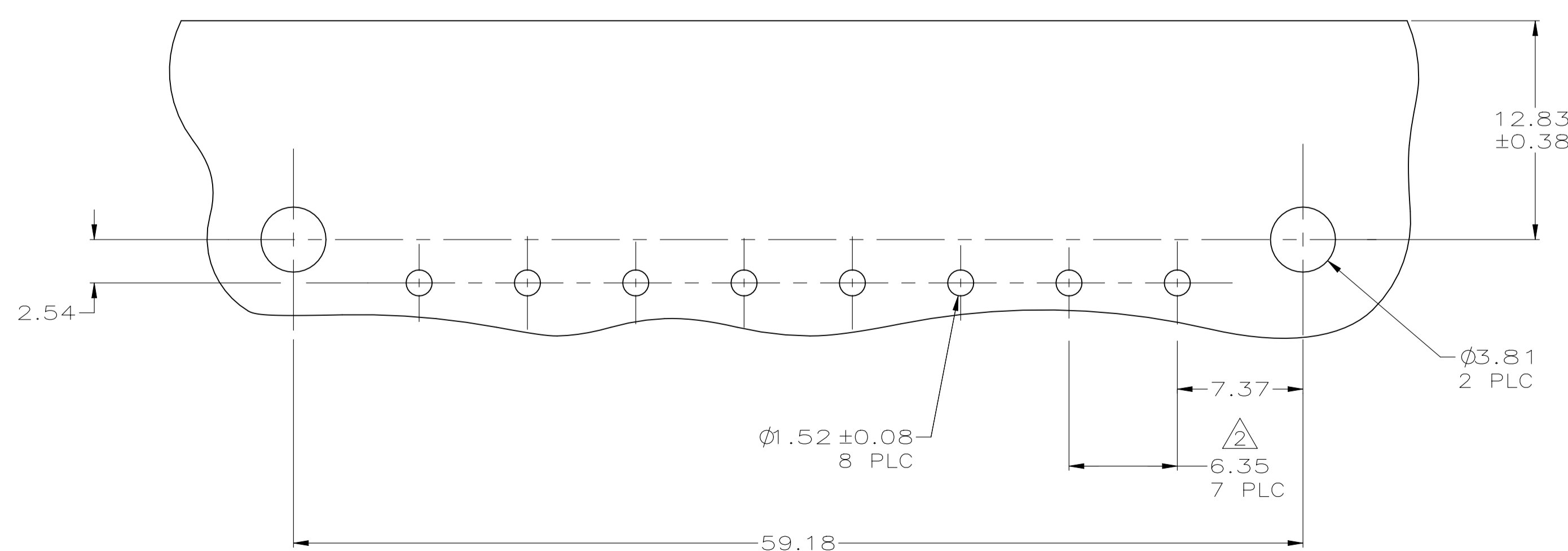

RECOMMENDED MOUNTING HOLE PATTERN FOR 1.57 THICK P.C. BOARD

2.03	.080	69.72	2.745
1.91	.075	59.18	2.330
1.57	.062	52.07	2.050
1.52	.060	17.27	.680
1.27	.050	12.83	.505
0.38	.015	9.14	.360
0.25	.010	7.37	.290
0.13	.005	6.35	.250
0.08	.003	4.06	.160
0.00127	.000050	3.81	.150
0.00076	.000030	2.54	.100
MM	IN	MM	IN

CONVERSION TABLE

PH BRZ GOLD	5	NYLON, UL94V-0	3-643236-0
PH BRZ GOLD	3	NYLON, UL94V-0	643236-2
PH BRZ TIN		NYLON, UL94V-0	643236-1
CONTACT		HOUSING	PART NO

THIS DRAWING IS A CONTROLLED DOCUMENT.		DIN K. WHITAKER 21APR2005		TE Connectivity	
DIMENSIONS: mm		CHK S. RIDGILL 21APR2005		NAME	
TOLERANCES UNLESS OTHERWISE SPECIFIED:		APVD S. RIDGILL 21APR2005		PRODUCT SPEC	
0. PLC ± -		APPLICATION SPEC		SIZE	
1. PLC ± -		SIZE		CASE CODE	
2. PLC ± 0.13		DRAWING NO		RESTRICTED TO	
3. PLC ± -		WEIGHT		CUSTOMER DRAWING	
4. PLC ± -		0.000000		SCALE 4:1	
ANGLES ± -		A1 00779		SHEET 1 of 1	
		C=643236		REV D2	