

16-Bit Registered Transceivers

Features

- I_{off} supports partial-power-down mode operation
- Edge-rate control circuitry for significantly improved noise characteristics
- Typical output skew < 250 ps
- ESD > 2000V
- TSSOP (19.6-mil pitch) and SSOP (25-mil pitch) packages
- Industrial temperature range of -40°C to $+85^{\circ}\text{C}$
- $V_{CC} = 5\text{V} \pm 10\%$

CY74FCT16646T Features:

- 64 mA sink current, 32 mA source current
- Typical V_{OLP} (ground bounce) < 1.0V at $V_{CC} = 5\text{V}$, $T_A = 25^{\circ}\text{C}$

CY74FCT162646T Features:

- Balanced 24 mA output drivers
- Reduced system switching noise
- Typical V_{OLP} (ground bounce) < 0.6V at $V_{CC} = 5\text{V}$, $T_A = 25^{\circ}\text{C}$

Functional Description

The CY74FCT16646T and CY74FCT162646T 16-bit transceivers are three-state, D-type registers, and control circuitry arranged for multiplexed transmission of data directly from the input bus or from the internal registers. Data on the A or B bus will be clocked into the registers as the appropriate clock pin goes to a HIGH logic level. Output Enable (\overline{OE}) and direction pins (DIR) are provided to control the transceiver function. In the transceiver mode, data present at the high impedance port may be stored in either the A or B register, or in both. The select controls can multiplex stored and real-time (transparent mode) data. The direction control determines which bus will receive data when the Output Enable (\overline{OE}) is Active LOW. In the isolation mode (Output Enable (\overline{OE}) HIGH), A data may be stored in the B register and/or B data may be stored in the A register.

This device is fully specified for partial-power-down applications using I_{off} . The I_{off} circuitry disables the outputs, preventing damaging current backflow through the device when it is powered down.

The CY74FCT16646T is ideally suited for driving high-capacitance loads and low-impedance backplanes.

The CY74FCT162646T has 24-mA balanced output drivers with current limiting resistors in the outputs. This reduces the need for external terminating resistors and provides for minimal undershoot and reduced ground bounce. The CY74FCT162646T is ideal for driving transmission lines.

Logic Block Diagrams

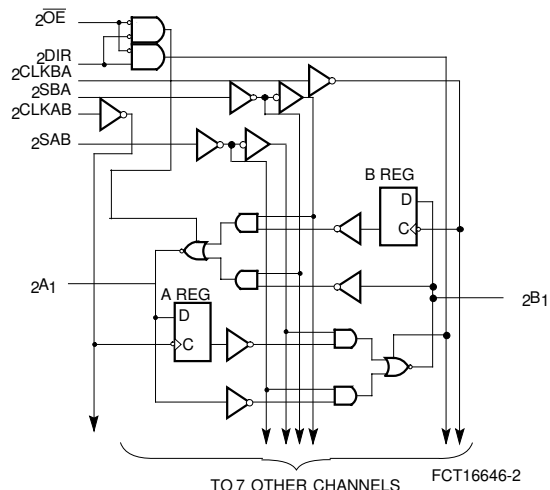
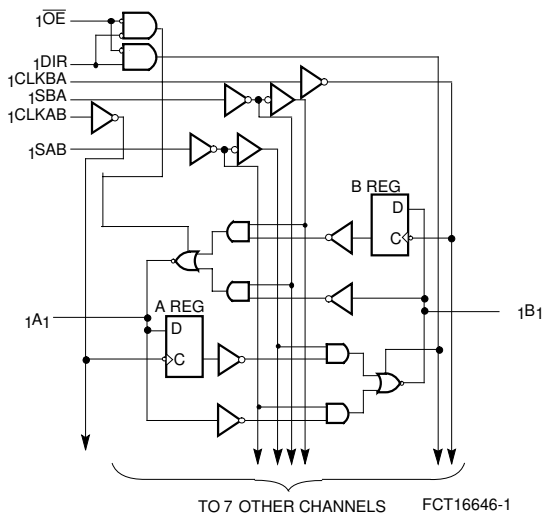

Pin Configuration

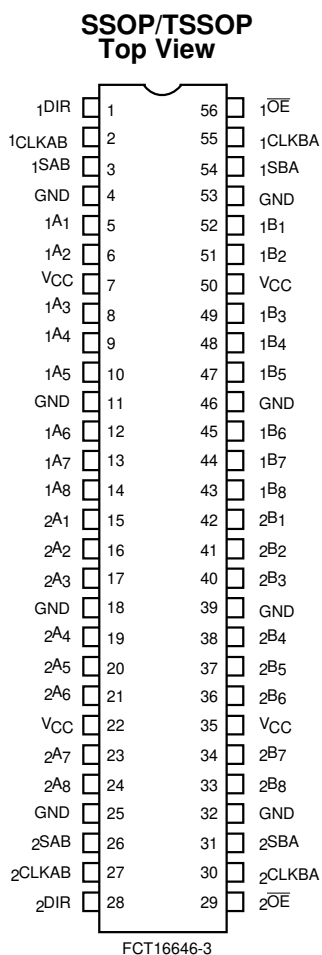

Pin Description

Pin Names	Description
A	Data Register A Inputs Data Register B Outputs
B	Data Register B Inputs Data Register A Outputs
CLKAB, CLKBA	Clock Pulse Inputs
SAB, SBA	Output Data Source Select Inputs
DIR	Direction
\overline{OE}	Output Enable (Active LOW)

Function Table^[1]

Inputs						Data I/O ^[2]		Function
\overline{OE}	DIR	CLKAB	CLKBA	SAB	SBA	A	B	
H	X	H or L	H or L	X	X	Input	Input	Isolation
H	X	┐	┐	X	X			Store A and B Data
L	L	X	X	X	L	Output	Input	Real Time B Data to A Bus
L	L	X	H or L	X	H			Stored B Data to A Bus
L	H	X	X	L	X	Input	Output	Real Time A Data to Bus
L	H	H or L	X	H	X			Stored A Data to B Bus

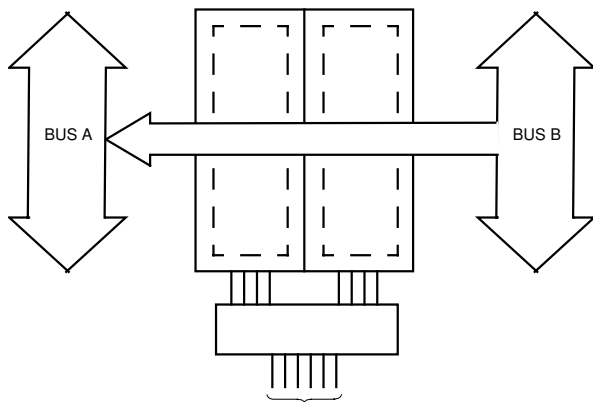

DIR L \overline{OE} L CLKAB X CLKBA X SAB X SBA L

Real-Time Transfer
Bus B to Bus A

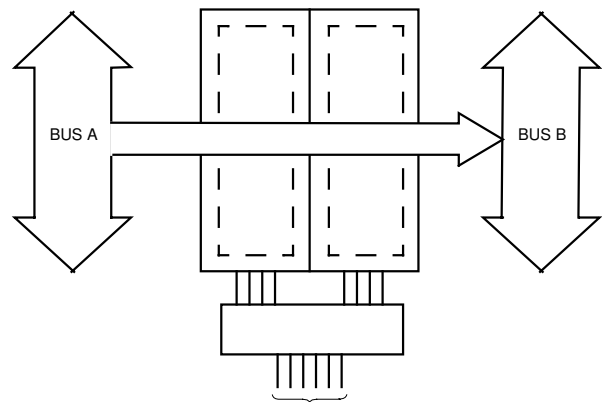

DIR H \overline{OE} L CLKAB X CLKBA X SAB L SBA X

Real-Time Transfer
Bus A to Bus B

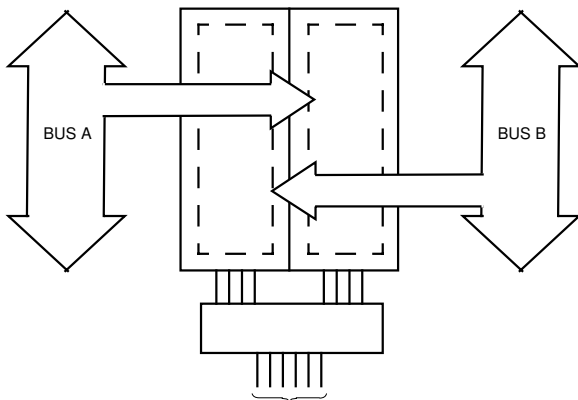

DIR H
L
X \overline{OE} L
L
H CLKAB
┐
X
┐ CLKBA
X
┐
┐ SAB X
X
X SBA X
X
X

Storage from
A and/or B

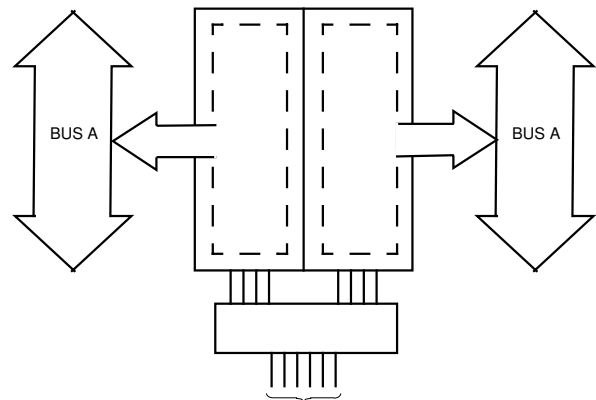

DIR^[3] L \overline{OE} L CLKAB X
H or L CLKBA H or L
X SAB X
H SBA H
X

Transfer Stored Data
to A and/or B

Notes:

1. H = HIGH Voltage Level. L = LOW Voltage Level. X = Don't Care ┐ = LOW-to-HIGH Transition
2. The data output functions may be enabled or disabled by various signals at the OE or DIR inputs. Data input functions are always enabled, i.e., data at the bus pins will be stored on every LOW-to-HIGH transition on the clock inputs.
3. Cannot transfer data to A-bus and B-bus simultaneously.

Maximum Ratings^[4]

(Above which the useful life may be impaired. For user guidelines, not tested.)

Storage TemperatureCom'l -55°C to +125°C

Ambient Temperature with
Power AppliedCom'l -55°C to +125°C

DC Input Voltage-0.5V to +7.0V

DC Output Voltage-0.5V to +7.0V

DC Output Current

(Maximum Sink Current/Pin)-60 to +120 mA

Power Dissipation 1.0W

Static Discharge Voltage.....>2001V
(per MIL-STD-883, Method 3015)

Operating Range

Range	Ambient Temperature	V _{CC}
Industrial	-40°C to +85°C	5V ± 10%

Electrical Characteristics Over the Operating Range

Parameter	Description	Test Conditions	Min.	Typ. ^[5]	Max.	Unit
V _{IH}	Input HIGH Voltage		2.0			V
V _{IL}	Input LOW Voltage				0.8	V
V _H	Input Hysteresis ^[6]			100		mV
V _{IK}	Input Clamp Diode Voltage	V _{CC} =Min., I _{IN} =-18 mA		-0.7	-1.2	V
I _{IH}	Input HIGH Current	V _{CC} =Max., V _I =V _{CC}			±1	μA
I _{IL}	Input LOW Current	V _{CC} =Max., V _I =GND			±1	μA
I _{OZH}	High Impedance Output Current (Three-State Output pins)	V _{CC} =Max., V _{OUT} =2.7V			±1	μA
I _{OZL}	High Impedance Output Current (Three-State Output pins)	V _{CC} =Max., V _{OUT} =0.5V			±1	μA
I _{OS}	Short Circuit Current ^[7]	V _{CC} =Max., V _{OUT} =GND	-80	-140	-200	mA
I _O	Output Drive Current ^[7]	V _{CC} =Max., V _{OUT} =2.5V	-50		-180	mA
I _{OFF}	Power-Off Disable	V _{CC} =0V, V _{OUT} ≤4.5V ^[9]			±1	μA

Output Drive Characteristics for CY74FCT16646T

Parameter	Description	Test Conditions	Min.	Typ. ^[5]	Max.	Unit
V _{OH}	Output HIGH Voltage	V _{CC} =Min., I _{OH} =-3 mA	2.5	3.5		V
		V _{CC} =Min., I _{OH} =-15 mA	2.4	3.5		V
		V _{CC} =Min., I _{OH} =-32 mA	2.0	3.0		V
V _{OL}	Output LOW Voltage	V _{CC} =Min., I _{OL} =64 mA		0.2	0.55	V

Output Drive Characteristics for CY74FCT162646T

Parameter	Description	Test Conditions	Min.	Typ. ^[5]	Max.	Unit
I _{ODL}	Output LOW Current ^[7]	V _{CC} =5V, V _{IN} =V _{IH} or V _{IL} , V _{OUT} =1.5V	60	115	150	mA
I _{ODH}	Output HIGH Current ^[7]	V _{CC} =5V, V _{IN} =V _{IH} or V _{IL} , V _{OUT} =1.5V	-60	-115	-150	mA
V _{OH}	Output HIGH Voltage	V _{CC} =Min., I _{OH} =-24 mA	2.4	3.3		V
V _{OL}	Output LOW Voltage	V _{CC} =Min., I _{OL} =24 mA		0.3	0.55	V

Notes:

- Stresses greater than those listed under Maximum Ratings may cause permanent damage to the device. This is a stress rating only and functional operation of the device at these or any other conditions above those indicated in the operational sections of this specification is not implied. Exposure to absolute maximum rating conditions for extended periods may affect reliability.
- Typical values are at V_{CC}= 5.0V, T_A= +25°C ambient.
- This parameter is specified but not tested.
- Not more than one output should be shorted at a time. Duration of short should not exceed one second. The use of high-speed test apparatus and/or sample and hold techniques are preferable in order to minimize internal chip heating and more accurately reflect operational values. Otherwise prolonged shorting of a high output may raise the chip temperature well above normal and thereby cause invalid readings in other parametrics tests. In any sequence of parameter tests, I_{OS} tests should be performed last.
- This parameter is measured at characterization but not tested.
- Tested at +25°C.

Capacitance ($T_A = +25^\circ\text{C}$, $f = 1.0\text{ MHz}$)

Symbol	Description ^[8]	Conditions	Typ.	Max.	Unit
C_{IN}	Input Capacitance	$V_{IN} = 0V$	4.5	6.0	pF
C_{OUT}	Output Capacitance	$V_{OUT} = 0V$	5.5	8.0	pF

Power Supply Characteristics

Parameter	Description	Test Conditions ^[10]		Min.	Typ. ^[5]	Max.	Unit
I_{CC}	Quiescent Power Supply Current	$V_{CC} = \text{Max.}$	$V_{IN} \leq 0.2V$ $V_{IN} \geq V_{CC} - 0.2V$	—	5	500	μA
ΔI_{CC}	Quiescent Power Supply Current TTL Inputs HIGH	$V_{CC} = \text{Max.}$ $V_{IN} = 3.4V$ ^[11]		—	0.5	1.5	mA
I_{CCD}	Dynamic Power Supply Current ^[12]	$V_{CC} = \text{Max.}$ Outputs Open DIR=OE=GND One-Bit Toggling 50% Duty Cycle	$V_{IN} = V_{CC}$ or $V_{IN} = \text{GND}$	—	75	120	$\mu\text{A}/\text{MHz}$
I_C	Total Power Supply Current ^[13]	$V_{CC} = \text{Max.}$ Outputs Open $f_0 = 10\text{ MHz}$ (CLKBA) 50% Duty Cycle DIR=OE=GND One-Bit Toggling $f_1 = 5\text{ MHz}$ 50% Duty Cycle	$V_{IN} = V_{CC}$ or $V_{IN} = \text{GND}$	—	0.8	1.7	mA
			$V_{IN} = 3.4V$ or $V_{IN} = \text{GND}$	—	1.3	3.2	
		$V_{CC} = \text{Max.}$ Outputs Open $f_0 = 10\text{ MHz}$ (CLKBA) 50% Duty Cycle DIR=OE=GND Sixteen-Bits Toggling $f_1 = 2.5\text{ MHz}$ 50% Duty Cycle	$V_{IN} = V_{CC}$ or $V_{IN} = \text{GND}$	—	3.8	6.5 ^[14]	
			$V_{IN} = 3.4V$ or $V_{IN} = \text{GND}$	—	8.3	20.0 ^[14]	

Notes:

10. For conditions shown as Max. or Min., use appropriate value specified under Electrical Characteristics for the applicable device type.
11. Per TTL driven input ($V_{IN} = 3.4V$); all other inputs at V_{CC} or GND.
12. This parameter is not directly testable, but is derived for use in Total Power Supply calculations.
13. $I_C = I_{QUIESCENT} + I_{INPUTS} + I_{DYNAMIC}$
 $I_C = I_{CC} + \Delta I_{CC} D_H N_T + I_{CCD}(f_0/2 + f_1 N_1)$
 I_{CC} = Quiescent Current with CMOS input levels
 ΔI_{CC} = Power Supply Current for a TTL HIGH input ($V_{IN} = 3.4V$)
 D_H = Duty Cycle for TTL inputs HIGH
 N_T = Number of TTL inputs at D_H
 I_{CCD} = Dynamic Current caused by an input transition pair (HLH or LHL)
 f_0 = Clock frequency for registered devices, otherwise zero
 f_1 = Input signal frequency
 N_1 = Number of inputs changing at f_1
 All currents are in milliamps and all frequencies are in megahertz.
14. Values for these conditions are examples of the I_{CC} formula. These limits are specified but not tested.

Switching Characteristics Over the Operating Range^[15]

Parameter	Description	CY74FCT16646T		CY74FCT16646AT CY74FCT162646AT		Unit	Fig. No. ^[16]
		Min.	Max.	Min.	Max.		
t _{PLH} t _{PHL}	Propagation Delay Bus to Bus	1.5	9.0	1.5	6.3	ns	1, 2
t _{PZH} t _{PZL}	Output Enable Time DIR or OE to Bus	1.5	14.0	1.5	9.8	ns	1, 7, 8
t _{PHZ} t _{PLZ}	Output Disable Time DIR or OE to Bus	1.5	9.0	1.5	6.3	ns	1, 7, 8
t _{PLH} t _{PHL}	Propagation Delay Clock to Bus	1.5	9.0	1.5	6.3	ns	1, 5
t _{PLH} t _{PHL}	Propagation Delay SBA or SAB to Bus	1.5	11.0	1.5	7.7	ns	1,5
t _{SU}	Set-Up Time HIGH or LOW Bus to Clock	2.0	—	2.0	—	ns	4
t _H	Hold Time HIGH or LOW Bus to Clock	1.5	—	1.5	—	ns	4
t _w	Clock Pulse Width HIGH or LOW	5.0	—	5.0	—	ns	6
t _{SK(O)}	Output Skew ^[17]	—	0.5	—	0.5	ns	—

Parameter	Description	CY74FCT16646CT CY74FCT162646CT		Unit	Fig. No. ^[16]
		Min.	Max.		
t _{PLH} t _{PHL}	Propagation Delay Bus to Bus	1.5	5.4	ns	1, 2
t _{PZH} t _{PZL}	Output Enable Time DIR or OE to Bus	1.5	7.8	ns	1, 7, 8
t _{PHZ} t _{PLZ}	Output Disable Time DIR or OE to Bus	1.5	6.3	ns	1, 7, 8
t _{PLH} t _{PHL}	Propagation Delay Clock to Bus	1.5	5.7	ns	1, 5
t _{PLH} t _{PHL}	Propagation Delay SBA or SAB to Bus	1.5	6.2	ns	1,5
t _{SU}	Set-Up Time HIGH or LOW Bus to Clock	2.0	—	ns	4
t _H	Hold Time HIGH or LOW Bus to Clock	1.5	—	ns	4
t _w	Clock Pulse Width HIGH or LOW	5.0	—	ns	6
t _{SK(O)}	Output Skew ^[17]	—	0.5	ns	—

Notes:

15. Minimum limits are specified but not tested on Propagation Delays.

16. See "Parameter Measurement Information" in the General Information section.

17. Skew any two outputs of the same package switching in the same direction. This parameter is ensured by design.

Ordering Information CY74FCT16646

Speed (ns)	Ordering Code	Package Name	Package Type	Operating Range
5.4	CY74FCT16646CTPVC/PVCT	O56	56-Lead (300-Mil) SSOP	Industrial
6.3	CY74FCT16646ATPVC/PVCT	O56	56-Lead (300-Mil) SSOP	Industrial
9.0	CY74FCT16646TPVC/PVCT	O56	56-Lead (300-Mil) SSOP	Industrial

Ordering Information CY74FCT162646

Speed (ns)	Ordering Code	Package Name	Package Type	Operating Range
5.4	74FCT162646CTPACT	Z56	56-Lead (240-Mil) TSSOP	Industrial
	CY74FCT162646CTPVC	O56	56-Lead (300-Mil) SSOP	
	74FCT162646CTPVCT	O56	56-Lead (300-Mil) SSOP	
6.3	74FCT162646ATPACT	Z56	56-Lead (240-Mil) TSSOP	Industrial
	CY74FCT162646ATPVC	O56	56-Lead (300-Mil) SSOP	
	74FCT162646ATPVCT	O56	56-Lead (300-Mil) SSOP	

Package Diagrams

56-Lead Shrunken Small Outline Package O56

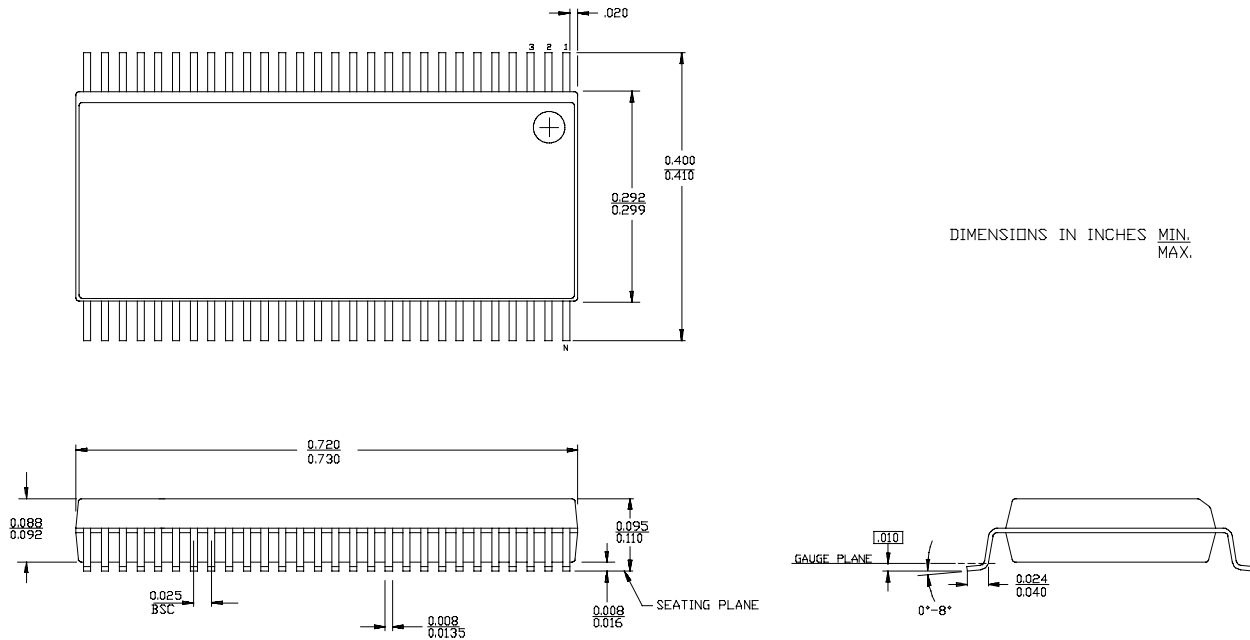

56-Lead Thin Shrunken Small Outline Package Z56

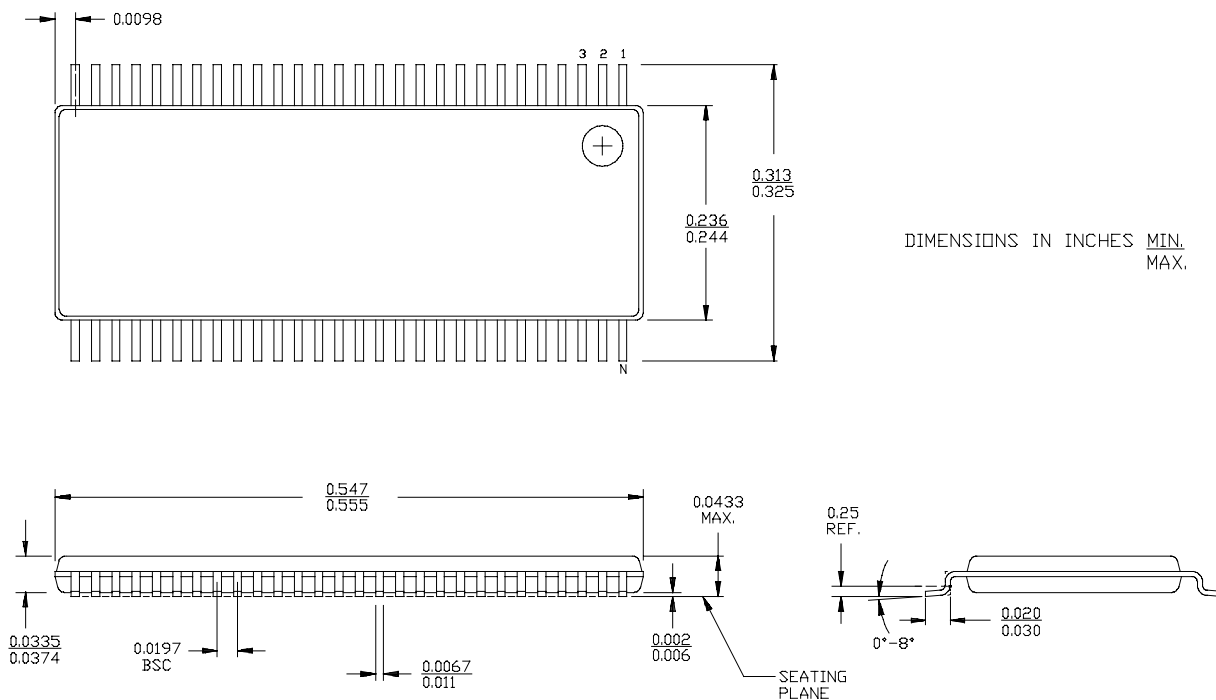

PACKAGING INFORMATION

Orderable Device	Status ⁽¹⁾	Package Type	Package Drawing	Pins	Package Qty	Eco Plan ⁽²⁾	Lead/Ball Finish	MSL Peak Temp ⁽³⁾
74FCT162646ATPACT	ACTIVE	TSSOP	DGG	56	2000	Green (RoHS & no Sb/Br)	CU NIPDAU	Level-1-260C-UNLIM
74FCT162646ATPVCG4	ACTIVE	SSOP	DL	56	20	Green (RoHS & no Sb/Br)	CU NIPDAU	Level-1-260C-UNLIM
74FCT162646ATPVCT	ACTIVE	SSOP	DL	56	1000	Green (RoHS & no Sb/Br)	CU NIPDAU	Level-1-260C-UNLIM
74FCT162646CTPACT	ACTIVE	TSSOP	DGG	56	2000	Green (RoHS & no Sb/Br)	CU NIPDAU	Level-1-260C-UNLIM
74FCT162646CTPVCG4	ACTIVE	SSOP	DL	56	20	Green (RoHS & no Sb/Br)	CU NIPDAU	Level-1-260C-UNLIM
74FCT162646CTPVCT	ACTIVE	SSOP	DL	56	1000	Green (RoHS & no Sb/Br)	CU NIPDAU	Level-1-260C-UNLIM
74FCT162646ETPACT	OBSOLETE	TSSOP	DGG	56		TBD	Call TI	Call TI
74FCT162646ETPVCT	OBSOLETE	SSOP	DL	56		TBD	Call TI	Call TI
74FCT16646ATPVCG4	ACTIVE	SSOP	DL	56	20	Green (RoHS & no Sb/Br)	CU NIPDAU	Level-1-260C-UNLIM
74FCT16646ATPVCTG4	ACTIVE	SSOP	DL	56	1000	Green (RoHS & no Sb/Br)	CU NIPDAU	Level-1-260C-UNLIM
74FCT16646CTPVCG4	ACTIVE	SSOP	DL	56	20	Green (RoHS & no Sb/Br)	CU NIPDAU	Level-1-260C-UNLIM
74FCT16646CTPVCTG4	ACTIVE	SSOP	DL	56	1000	Green (RoHS & no Sb/Br)	CU NIPDAU	Level-1-260C-UNLIM
74FCT16646TPVCG4	ACTIVE	SSOP	DL	56	20	Green (RoHS & no Sb/Br)	CU NIPDAU	Level-1-260C-UNLIM
74FCT16646TPVCTG4	ACTIVE	SSOP	DL	56	1000	Green (RoHS & no Sb/Br)	CU NIPDAU	Level-1-260C-UNLIM
CY74FCT162646ATPVC	ACTIVE	SSOP	DL	56	20	Green (RoHS & no Sb/Br)	CU NIPDAU	Level-1-260C-UNLIM
CY74FCT162646CTPVC	ACTIVE	SSOP	DL	56	20	Green (RoHS & no Sb/Br)	CU NIPDAU	Level-1-260C-UNLIM
CY74FCT162646ETPAC	OBSOLETE	TSSOP	DGG	56		TBD	Call TI	Call TI
CY74FCT162646ETPVC	OBSOLETE	SSOP	DL	56		TBD	Call TI	Call TI
CY74FCT16646ATPVC	ACTIVE	SSOP	DL	56	20	Green (RoHS & no Sb/Br)	CU NIPDAU	Level-1-260C-UNLIM
CY74FCT16646ATPVCT	ACTIVE	SSOP	DL	56	1000	Green (RoHS & no Sb/Br)	CU NIPDAU	Level-1-260C-UNLIM
CY74FCT16646CTPVC	ACTIVE	SSOP	DL	56	20	Green (RoHS & no Sb/Br)	CU NIPDAU	Level-1-260C-UNLIM
CY74FCT16646CTPVCT	ACTIVE	SSOP	DL	56	1000	Green (RoHS & no Sb/Br)	CU NIPDAU	Level-1-260C-UNLIM
CY74FCT16646ETPVC	OBSOLETE	SSOP	DL	56		TBD	Call TI	Call TI
CY74FCT16646ETPVCT	OBSOLETE	SSOP	DL	56		TBD	Call TI	Call TI
CY74FCT16646TPVC	ACTIVE	SSOP	DL	56	20	Green (RoHS & no Sb/Br)	CU NIPDAU	Level-1-260C-UNLIM
CY74FCT16646TPVCT	ACTIVE	SSOP	DL	56	1000	Green (RoHS & no Sb/Br)	CU NIPDAU	Level-1-260C-UNLIM
FCT162646ATPACTE4	ACTIVE	TSSOP	DGG	56	2000	Green (RoHS & no Sb/Br)	CU NIPDAU	Level-1-260C-UNLIM

Orderable Device	Status ⁽¹⁾	Package Type	Package Drawing	Pins	Package Qty	Eco Plan ⁽²⁾	Lead/Ball Finish	MSL Peak Temp ⁽³⁾
FCT162646ATPACTG4	ACTIVE	TSSOP	DGG	56	2000	Green (RoHS & no Sb/Br)	CU NIPDAU	Level-1-260C-UNLIM
FCT162646ATPVCTG4	ACTIVE	SSOP	DL	56	1000	Green (RoHS & no Sb/Br)	CU NIPDAU	Level-1-260C-UNLIM
FCT162646CTPACTE4	ACTIVE	TSSOP	DGG	56	2000	Green (RoHS & no Sb/Br)	CU NIPDAU	Level-1-260C-UNLIM
FCT162646CTPACTG4	ACTIVE	TSSOP	DGG	56	2000	Green (RoHS & no Sb/Br)	CU NIPDAU	Level-1-260C-UNLIM
FCT162646CTPVCTG4	ACTIVE	SSOP	DL	56	1000	Green (RoHS & no Sb/Br)	CU NIPDAU	Level-1-260C-UNLIM

⁽¹⁾ The marketing status values are defined as follows:

ACTIVE: Product device recommended for new designs.

LIFEBUY: TI has announced that the device will be discontinued, and a lifetime-buy period is in effect.

NRND: Not recommended for new designs. Device is in production to support existing customers, but TI does not recommend using this part in a new design.

PREVIEW: Device has been announced but is not in production. Samples may or may not be available.

OBsolete: TI has discontinued the production of the device.

⁽²⁾ Eco Plan - The planned eco-friendly classification: Pb-Free (RoHS), Pb-Free (RoHS Exempt), or Green (RoHS & no Sb/Br) - please check <http://www.ti.com/productcontent> for the latest availability information and additional product content details.

TBD: The Pb-Free/Green conversion plan has not been defined.

Pb-Free (RoHS): TI's terms "Lead-Free" or "Pb-Free" mean semiconductor products that are compatible with the current RoHS requirements for all 6 substances, including the requirement that lead not exceed 0.1% by weight in homogeneous materials. Where designed to be soldered at high temperatures, TI Pb-Free products are suitable for use in specified lead-free processes.

Pb-Free (RoHS Exempt): This component has a RoHS exemption for either 1) lead-based flip-chip solder bumps used between the die and package, or 2) lead-based die adhesive used between the die and leadframe. The component is otherwise considered Pb-Free (RoHS compatible) as defined above.

Green (RoHS & no Sb/Br): TI defines "Green" to mean Pb-Free (RoHS compatible), and free of Bromine (Br) and Antimony (Sb) based flame retardants (Br or Sb do not exceed 0.1% by weight in homogeneous material)

⁽³⁾ MSL, Peak Temp. -- The Moisture Sensitivity Level rating according to the JEDEC industry standard classifications, and peak solder temperature.

Important Information and Disclaimer: The information provided on this page represents TI's knowledge and belief as of the date that it is provided. TI bases its knowledge and belief on information provided by third parties, and makes no representation or warranty as to the accuracy of such information. Efforts are underway to better integrate information from third parties. TI has taken and continues to take reasonable steps to provide representative and accurate information but may not have conducted destructive testing or chemical analysis on incoming materials and chemicals. TI and TI suppliers consider certain information to be proprietary, and thus CAS numbers and other limited information may not be available for release.

In no event shall TI's liability arising out of such information exceed the total purchase price of the TI part(s) at issue in this document sold by TI to Customer on an annual basis.

TAPE AND REEL INFORMATION

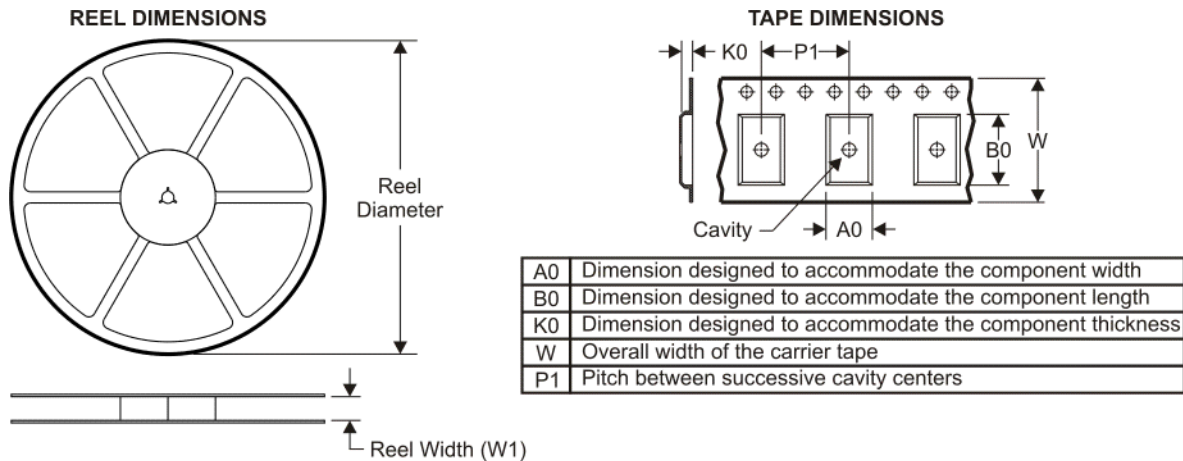

QUADRANT ASSIGNMENTS FOR PIN 1 ORIENTATION IN TAPE

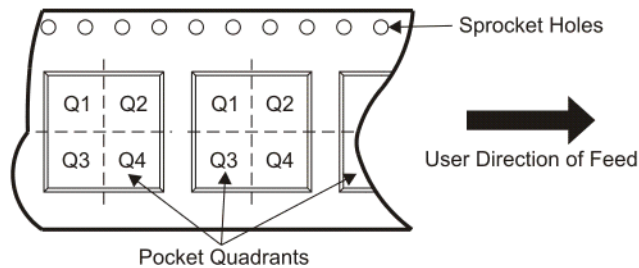

*All dimensions are nominal

Device	Package Type	Package Drawing	Pins	SPQ	Reel Diameter (mm)	Reel Width W1 (mm)	A0 (mm)	B0 (mm)	K0 (mm)	P1 (mm)	W (mm)	Pin1 Quadrant
74FCT162646ATPACT	TSSOP	DGG	56	2000	330.0	24.4	8.6	15.6	1.8	12.0	24.0	Q1
74FCT162646ATPVCT	SSOP	DL	56	1000	330.0	32.4	11.35	18.67	3.1	16.0	32.0	Q1
74FCT162646CTPACT	TSSOP	DGG	56	2000	330.0	24.4	8.6	15.6	1.8	12.0	24.0	Q1
74FCT162646CTPVCT	SSOP	DL	56	1000	330.0	32.4	11.35	18.67	3.1	16.0	32.0	Q1
CY74FCT16646ATPVCT	SSOP	DL	56	1000	330.0	32.4	11.35	18.67	3.1	16.0	32.0	Q1
CY74FCT16646CTPVCT	SSOP	DL	56	1000	330.0	32.4	11.35	18.67	3.1	16.0	32.0	Q1
CY74FCT16646TPVCT	SSOP	DL	56	1000	330.0	32.4	11.35	18.67	3.1	16.0	32.0	Q1

TAPE AND REEL BOX DIMENSIONS



*All dimensions are nominal

Device	Package Type	Package Drawing	Pins	SPQ	Length (mm)	Width (mm)	Height (mm)
74FCT162646ATPACT	TSSOP	DGG	56	2000	346.0	346.0	41.0
74FCT162646ATPVCT	SSOP	DL	56	1000	346.0	346.0	49.0
74FCT162646CTPACT	TSSOP	DGG	56	2000	346.0	346.0	41.0
74FCT162646CTPVCT	SSOP	DL	56	1000	346.0	346.0	49.0
CY74FCT16646ATPVCT	SSOP	DL	56	1000	346.0	346.0	49.0
CY74FCT16646CTPVCT	SSOP	DL	56	1000	346.0	346.0	49.0
CY74FCT16646TPVCT	SSOP	DL	56	1000	346.0	346.0	49.0

DL (R-PDSO-G**)

PLASTIC SMALL-OUTLINE PACKAGE

48 PINS SHOWN

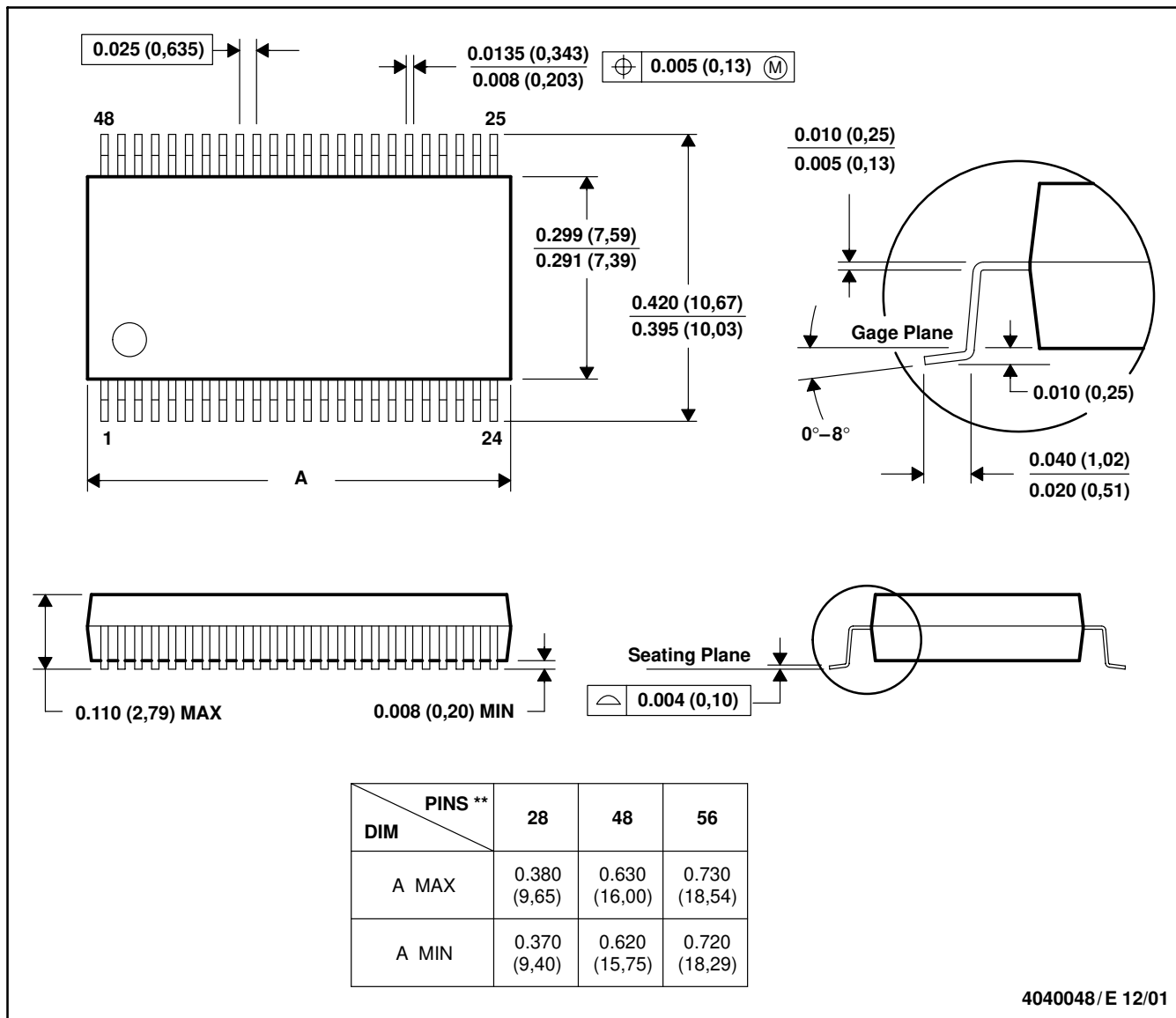

- NOTES: A. All linear dimensions are in inches (millimeters).
 B. This drawing is subject to change without notice.
 C. Body dimensions do not include mold flash or protrusion not to exceed 0.006 (0,15).
 D. Falls within JEDEC MO-118

DGG (R-PDSO-G**)

PLASTIC SMALL-OUTLINE PACKAGE

48 PINS SHOWN

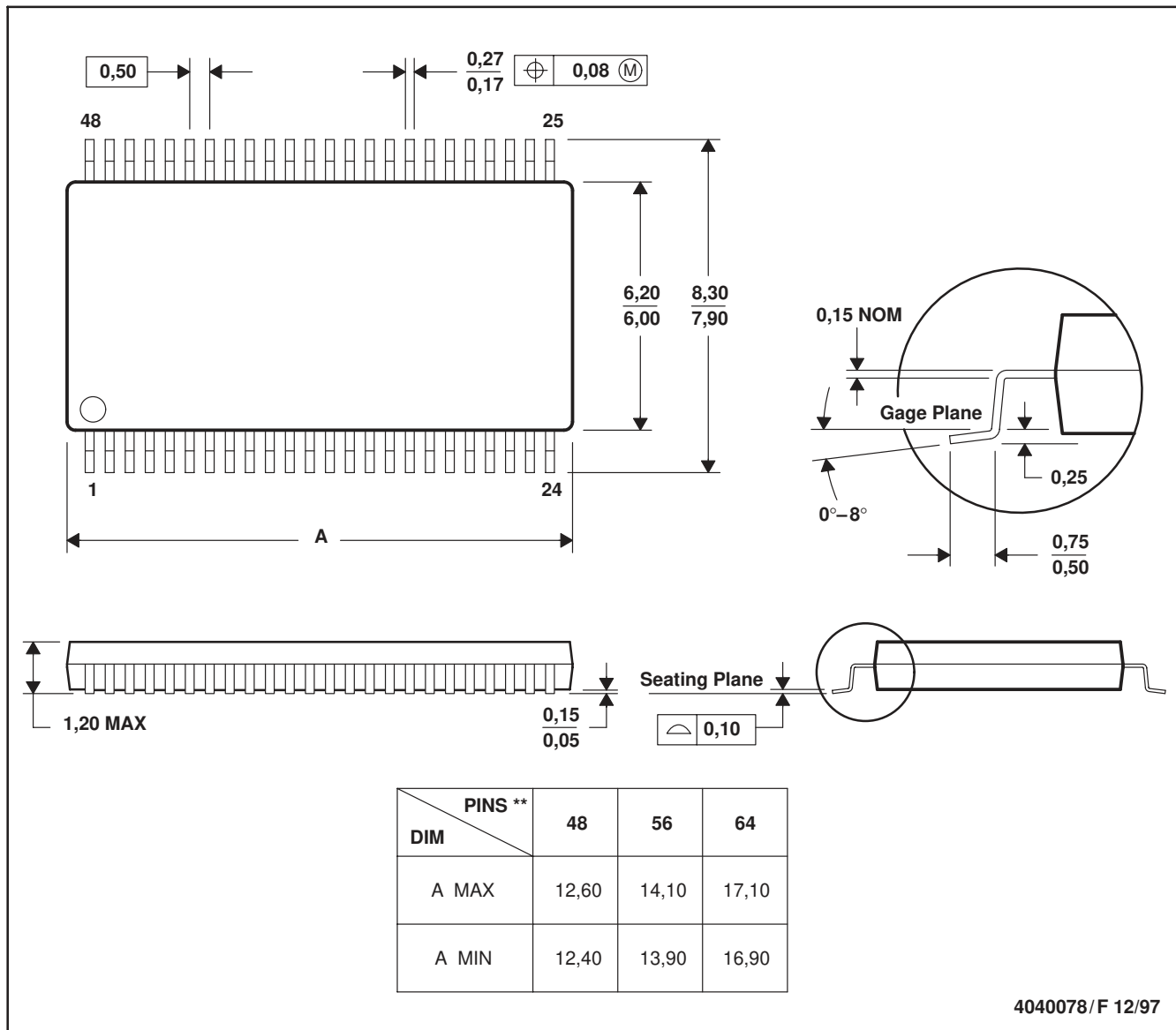

- NOTES: A. All linear dimensions are in millimeters.
 B. This drawing is subject to change without notice.
 C. Body dimensions do not include mold protrusion not to exceed 0,15.
 D. Falls within JEDEC MO-153

IMPORTANT NOTICE

Texas Instruments Incorporated and its subsidiaries (TI) reserve the right to make corrections, modifications, enhancements, improvements, and other changes to its products and services at any time and to discontinue any product or service without notice. Customers should obtain the latest relevant information before placing orders and should verify that such information is current and complete. All products are sold subject to TI's terms and conditions of sale supplied at the time of order acknowledgment.

TI warrants performance of its hardware products to the specifications applicable at the time of sale in accordance with TI's standard warranty. Testing and other quality control techniques are used to the extent TI deems necessary to support this warranty. Except where mandated by government requirements, testing of all parameters of each product is not necessarily performed.

TI assumes no liability for applications assistance or customer product design. Customers are responsible for their products and applications using TI components. To minimize the risks associated with customer products and applications, customers should provide adequate design and operating safeguards.

TI does not warrant or represent that any license, either express or implied, is granted under any TI patent right, copyright, mask work right, or other TI intellectual property right relating to any combination, machine, or process in which TI products or services are used. Information published by TI regarding third-party products or services does not constitute a license from TI to use such products or services or a warranty or endorsement thereof. Use of such information may require a license from a third party under the patents or other intellectual property of the third party, or a license from TI under the patents or other intellectual property of TI.

Reproduction of TI information in TI data books or data sheets is permissible only if reproduction is without alteration and is accompanied by all associated warranties, conditions, limitations, and notices. Reproduction of this information with alteration is an unfair and deceptive business practice. TI is not responsible or liable for such altered documentation. Information of third parties may be subject to additional restrictions.

Resale of TI products or services with statements different from or beyond the parameters stated by TI for that product or service voids all express and any implied warranties for the associated TI product or service and is an unfair and deceptive business practice. TI is not responsible or liable for any such statements.

TI products are not authorized for use in safety-critical applications (such as life support) where a failure of the TI product would reasonably be expected to cause severe personal injury or death, unless officers of the parties have executed an agreement specifically governing such use. Buyers represent that they have all necessary expertise in the safety and regulatory ramifications of their applications, and acknowledge and agree that they are solely responsible for all legal, regulatory and safety-related requirements concerning their products and any use of TI products in such safety-critical applications, notwithstanding any applications-related information or support that may be provided by TI. Further, Buyers must fully indemnify TI and its representatives against any damages arising out of the use of TI products in such safety-critical applications.

TI products are neither designed nor intended for use in military/aerospace applications or environments unless the TI products are specifically designated by TI as military-grade or "enhanced plastic." Only products designated by TI as military-grade meet military specifications. Buyers acknowledge and agree that any such use of TI products which TI has not designated as military-grade is solely at the Buyer's risk, and that they are solely responsible for compliance with all legal and regulatory requirements in connection with such use.

TI products are neither designed nor intended for use in automotive applications or environments unless the specific TI products are designated by TI as compliant with ISO/TS 16949 requirements. Buyers acknowledge and agree that, if they use any non-designated products in automotive applications, TI will not be responsible for any failure to meet such requirements.

Following are URLs where you can obtain information on other Texas Instruments products and application solutions:

Products

Amplifiers	amplifier.ti.com
Data Converters	dataconverter.ti.com
DSP	dsp.ti.com
Clocks and Timers	www.ti.com/clocks
Interface	interface.ti.com
Logic	logic.ti.com
Power Mgmt	power.ti.com
Microcontrollers	microcontroller.ti.com
RFID	www.ti-rfid.com
RF/IF and ZigBee® Solutions	www.ti.com/lprf

Applications

Audio	www.ti.com/audio
Automotive	www.ti.com/automotive
Broadband	www.ti.com/broadband
Digital Control	www.ti.com/digitalcontrol
Medical	www.ti.com/medical
Military	www.ti.com/military
Optical Networking	www.ti.com/opticalnetwork
Security	www.ti.com/security
Telephony	www.ti.com/telephony
Video & Imaging	www.ti.com/video
Wireless	www.ti.com/wireless

Mailing Address: Texas Instruments, Post Office Box 655303, Dallas, Texas 75265
Copyright © 2008, Texas Instruments Incorporated