

## Evaluating the **AD5341** 12-Bit, Single-Channel, Voltage Output, Digital-to-Analog Converter (DAC)

### FEATURES

- Full featured evaluation board (**EVAL-AD5341DBZ**) in conjunction with the nanoDAC motherboard (**EVAL-MBnanoDAC-SDZ**)
- On-board references
- Various link options
- PC control in conjunction with Analog Devices, Inc., system demonstration platform

### PACKAGE CONTENTS

- EVAL-AD5341DBZ** evaluation board
- EVAL-MBnanoDAC-SDZ** motherboard

### SOFTWARE REQUIRED

- EVAL-AD5341DBZ** evaluation software

### HARDWARE REQUIRED

- EVAL-SDP-CB1Z** controller board (**SDP-B** controller board), must be purchased separately

### GENERAL DESCRIPTION

This user guide details the operation of the evaluation board for the **AD5341** single-channel, voltage output DAC.

The **EVAL-AD5341DBZ** evaluation board helps users quickly prototype new **AD5341** circuits and reduce design times. The **AD5341** operates from a single 2.5 V to 5.5 V supply.

For full data, see the **AD5341** data sheet, which must be used in conjunction with this user guide when using the evaluation board.

The **EVAL-AD5341DBZ** interfaces to the USB port of a PC via the **SDP-B** controller board. Software can be downloaded via the **EVAL-AD5341DBZ** product page that allows users to program the **AD5341**.

The **EVAL-AD5341DBZ** evaluation board requires the **EVAL-SDP-CB1Z** board (**SDP-B** controller board).

### EVAL-AD5341DBZ, EVAL-MBnanoDAC-SDZ, AND EVAL-SDP-CB1Z BOARDS

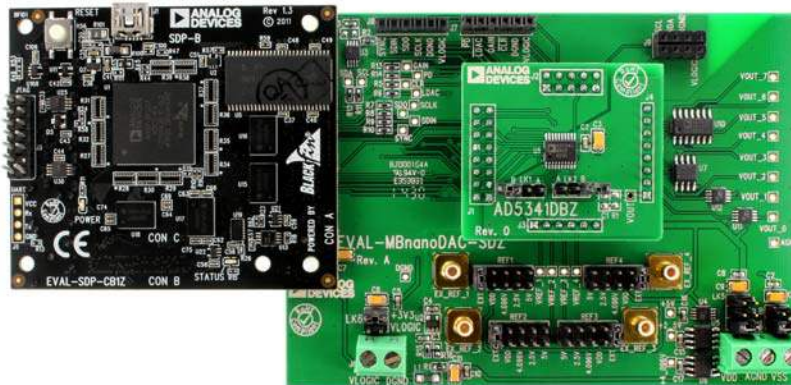

Figure 1.

**TABLE OF CONTENTS**

Features .....	1	Daughter Board Link Options.....	3
Package Contents.....	1	Evaluation Board Software Quick Start Procedures.....	4
Software Required .....	1	Installing the Software .....	4
Hardware Required .....	1	Running the Software .....	4
General Description .....	1	Software Operation .....	5
EVAL-AD5341DBZ, EVAL-MBnanoDAC-SDZ, and EVAL-SDP-CB1Z Boards .....	1	Evaluation Board Schematics and Artwork.....	6
Revision History .....	2	EVAL-MBnanoDAC-SDZ Motherboard .....	6
Evaluation Board Hardware.....	3	EVAL-AD5341DBZ Daughter Board .....	9
Power Supplies .....	3	Ordering Information.....	11
Link Options .....	3	Bill of Materials.....	11

**REVISION HISTORY**

**2/2017—Revision 0: Initial Version**

## EVALUATION BOARD HARDWARE

### POWER SUPPLIES

The EVAL-AD5341DBZ evaluation board can be powered either from the SDP-B port or externally by the J5 and J6 connectors, as described in Table 1.

The nanoDAC® EVAL-MBnanoDAC-SDZ motherboard supports single and dual power supplies.

Both AGND and DGND inputs are provided on the EVAL-AD5341DBZ evaluation board. The AGND and DGND planes are connected at one location on the EVAL-MBnanoDAC-SDZ. It is recommended that AGND and DGND not be connected elsewhere in the system to avoid ground loop problems.

All supplies are decoupled to ground with 10 µF tantalum and 0.1 µF ceramic capacitors.

**Table 1. Power Supply Connectors**

Connector No.	Label	Voltage
J5, Pin 1 (J5-1)	VDD	Analog positive power supply, V <sub>DD</sub> ; 5.5 V single and dual supply
J5, Pin 2 (J5-2)	AGND	Analog ground
J5, Pin 3 (J5-3)	VSS	Analog negative power supply, V <sub>SS</sub> ; -5.5 V dual supply
J6, Pin 1 (J6-1)	VLOGIC	Digital supply from 1.8 V to V <sub>DD</sub>
J6, Pin 2 (J6-2)	DGND	Digital ground

### LINK OPTIONS

Various link options are incorporated in the EVAL-MBnanoDAC-SDZ and must be set for the required operating conditions before using the EVAL-AD5341DBZ. Table 2 describes the positions of

**Table 4. Link Functions**

Link Number	Function
REF1, REF2	This link selects the reference source. Position EXT selects an off board voltage reference via the appropriate EXT_REF connector. Position VDD selects VDD as the reference source. Position 4.096V selects the on-board 4.096 V reference as the reference source. Position 2.5V selects the on-board 2.5 V reference as the reference source. Position 5V selects the on-board 5 V reference as the reference source.
REF3, REF4	This link selects the reference source. Position EXT selects an off board voltage reference via the appropriate EXT_REF connector. Position VDD selects VDD as the reference source. Position 4.096V selects the on-board 4.096 V reference as the reference source. Position 2.5V selects the on-board 2.5 V reference as the reference source. Position 5V selects the on-board 5 V reference as the reference source.
LK5	This link selects the positive DAC analog voltage source. Position A selects the internal voltage source from the SDP-B board. Position B selects the internal voltage source, 3.3 V, from the ADP121 on the motherboard. Position C selects the external supply voltage, V <sub>DD</sub> .
LK6	This link selects the V <sub>LOGIC</sub> voltage source. Position +3V3 selects the digital voltage source from the SDP-B board (3.3 V). Position VLOGIC selects an external digital supply voltage (V <sub>LOGIC</sub> ).
LK7	This link selects the negative DAC analog voltage source. Position A selects V <sub>SS</sub> . Position B selects AGND.

the links to control the EVAL-AD5341DBZ via the SDP-B board using a PC and external power supplies. The functions of these link options are described in detail in Table 4. The positions listed in Table 2 to Table 4 match the evaluation board imprints (see Figure 11).

**Table 2. Link Options Setup for SDP-B Control (Default)**

Link Number	Position
REF1	EXT
REF2	EXT
REF3	EXT
REF4	EXT
LK5	C
LK6	+3V3
LK7	B

### DAUGHTER BOARD LINK OPTIONS

The EVAL-AD5341DBZ daughter board has two link options. The links control the settings for the reference BUF and CLR pins. Table 3 shows how the links are configured.

**Table 3. Link Options for Daughter Board**

Link Number	Pin	Position
LK1	BUF	A (unbuffered, default) B (buffered)
LK2	CLR	A (no operation, default) B (zero scale)

## EVALUATION BOARD SOFTWARE QUICK START PROCEDURES

### INSTALLING THE SOFTWARE

The [EVAL-AD5341DBZ](#) evaluation software is compatible with Windows® Vista (64-bit/32-bit) and Windows 7 (64-bit/32-bit).

Install the software before connecting the [SDP-B](#) board to the USB port of the PC to ensure that the [SDP-B](#) board is recognized when it connects to the PC.

To install the [EVAL-AD5341DBZ](#) software, take the following steps:

1. Start the Windows operating system.
2. Download the installation software from the [EVAL-AD5341DBZ](#) evaluation board page.
3. Run the **setup.exe** file from the installer folder if it does not open automatically.
4. Power up the [EVAL-AD5341DBZ](#) as described in the Power Supplies section after installation is completed.
5. Connect the [EVAL-AD5341DBZ](#) to the [SDP-B](#) and the [SDP-B](#) to the PC using the USB cable included in the evaluation kit.
6. Proceed through any dialog boxes that appear to finalize the installation when the software detects the [EVAL-AD5341DBZ](#).

### RUNNING THE SOFTWARE

To run the [EVAL-AD5341DBZ](#) software, take the following steps:

1. Connect the [EVAL-AD5341DBZ](#) to the [SDP-B](#) and connect the USB cable between the [SDP-B](#) and the PC.
2. Power up the [EVAL-AD5341DBZ](#) as described in the Power Supplies section.
3. Click **Start > All Programs > Analog Devices > AD5341**.

If the [SDP-B](#) is not connected to the USB port when the software is launched, a connectivity error displays (see Figure 2).

Connect the [SDP-B](#) to the USB port of the PC and wait a few seconds. When the [SDP-B](#) and the [EVAL-AD5341DBZ](#) are detected, the display updates (see Figure 3).

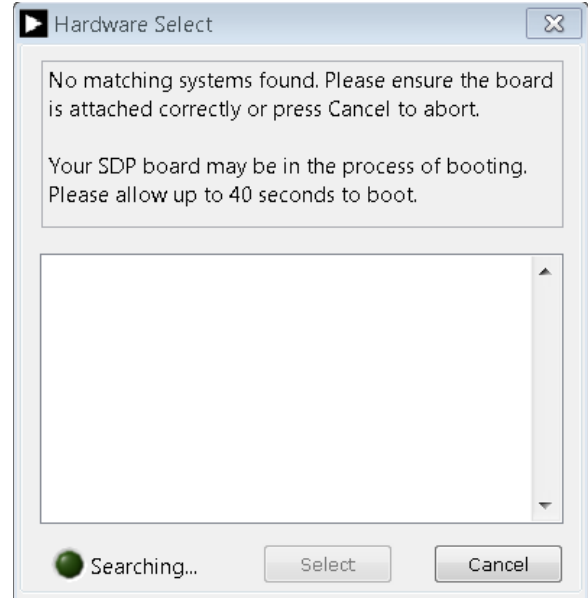

Figure 2. Connectivity Error

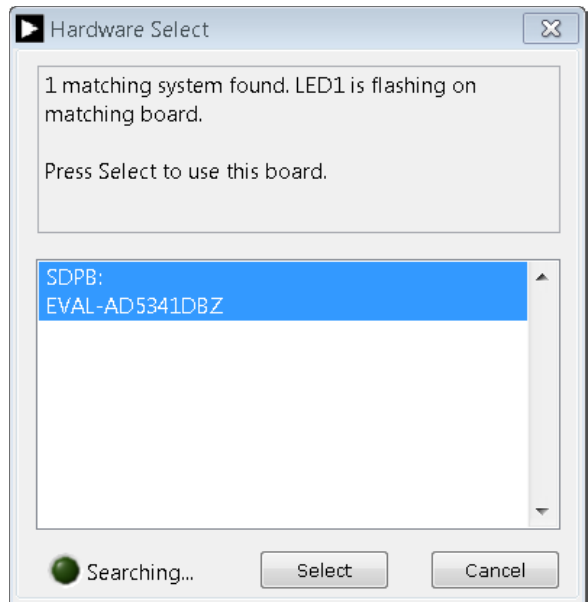

Figure 3. Hardware Select

Alternatively, the software can be used without an evaluation board. The software runs in simulation mode displaying expected outputs based on the input data. The main window of the [AD5341](#) evaluation software then opens, as shown in Figure 4.

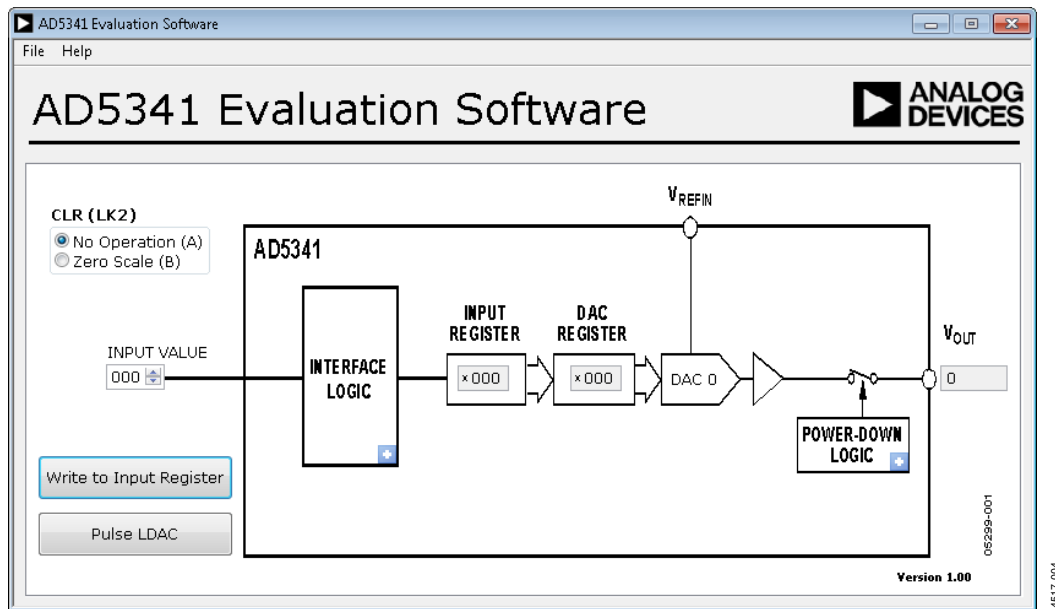

Figure 4. AD5341 Evaluation Board Software Main Window

**SOFTWARE OPERATION**

The software for the AD5341 allows users to program values to the input and DAC registers of the DAC.

**Write to Input Register**

Click **Write to Input Register** to load the code of the input data control to the input register of the DAC.

**LDAC Control**

Click **Pulse LDAC** to bring the LDAC pin low and then back to high, which copies the data from the input registers to the DAC registers, and the outputs update accordingly. Alternatively, set the LDAC pin high or low by clicking the blue progressive disclosure button in the **INTERFACE LOGIC** block. A window then opens that allows the user to click the appropriate LDAC setting, as shown in Figure 5.

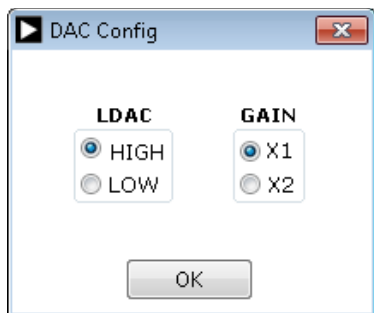

Figure 5. DAC Config Window

**GAIN Control**

Set the GAIN pin high or low by clicking the blue progressive disclosure button in the **INTERFACE LOGIC** block. A window then opens that allows the user to click the appropriate GAIN setting, as shown in Figure 5. Click **GAIN X1** to set a full-scale output of 2.5 V or click **GAIN X2** to set a full-scale output of 5 V.

**Power-Down Control**

Click the blue progressive disclosure button in the **POWER-DOWN LOGIC** block to access a selection box that allows the device to operate in normal mode or power-down mode. A window then opens that allows the user to click the power-down setting for the DAC, as shown in Figure 6. Click **OK** to write the appropriate values to the AD5341 when the power-down settings for the DAC are selected.

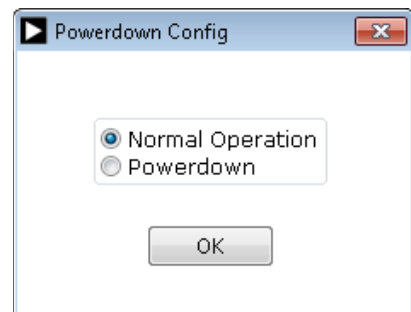

Figure 6. Powerdown Config Window

**CLR Control**

Set the CLR pin high or low using LK2 as described in the Daughter Board Link Options section and Table 3. Click the appropriate CLR (LK2) setting on the GUI to match the daughter board setting (see Figure 4).

EVALUATION BOARD SCHEMATICS AND ARTWORK  
 EVAL-MBnanoDAC-SDZ MOTHERBOARD

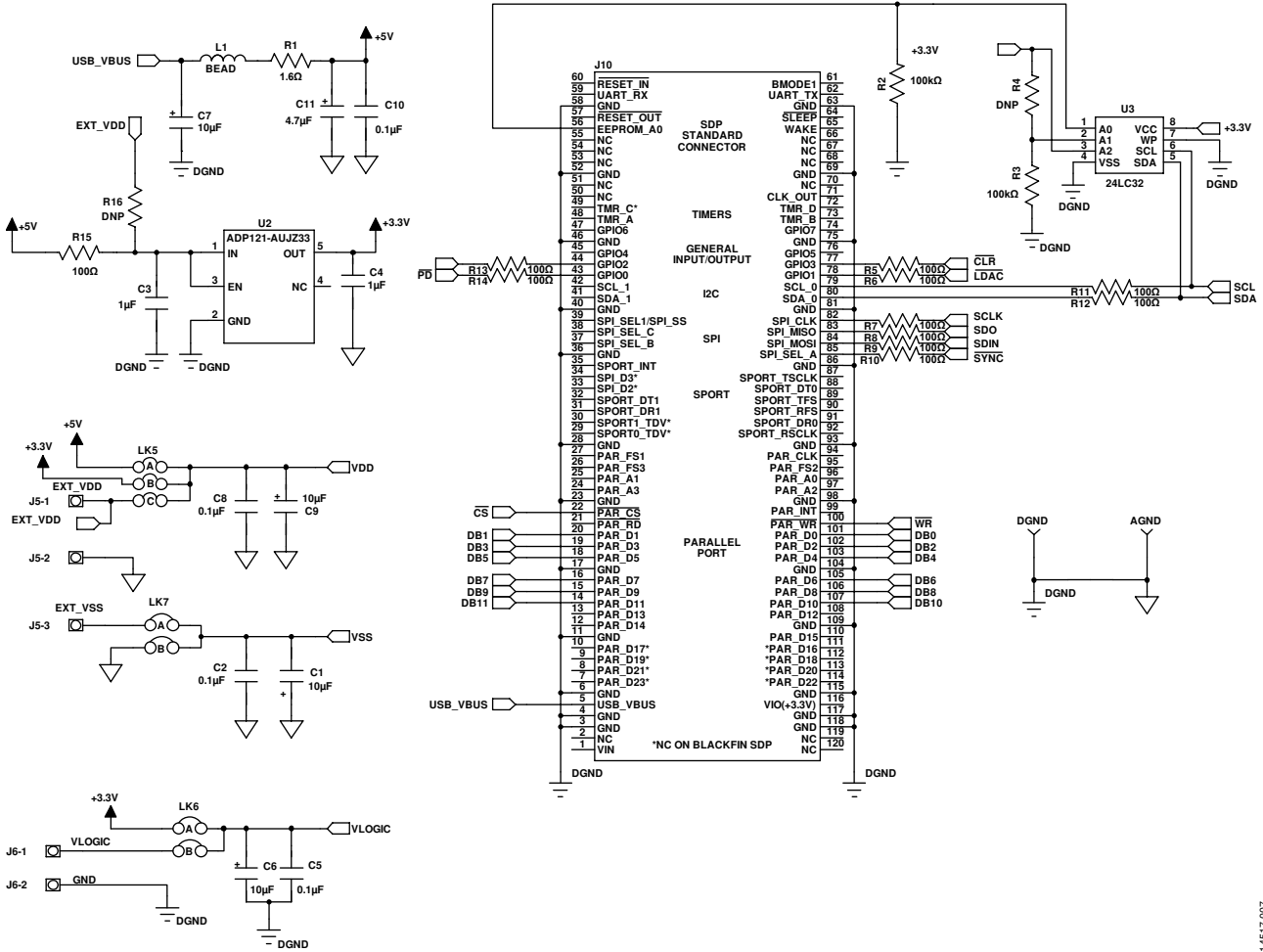

Figure 7. EVAL-MBnanoDAC-SDZ Motherboard SDP-B Connector and Power Supply

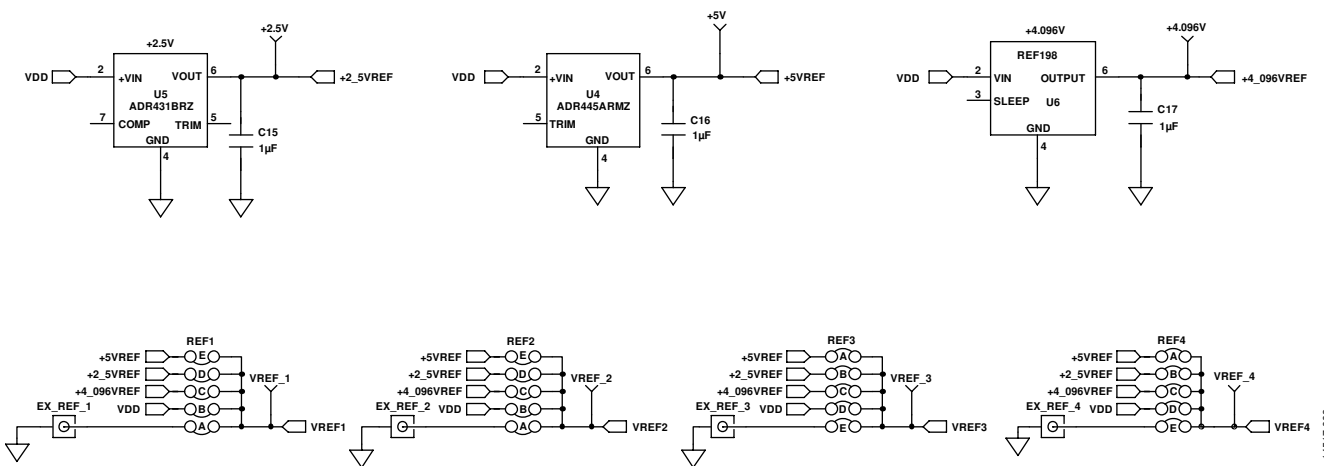

Figure 8. EVAL-MBnanoDAC-SDZ Motherboard Reference Voltage Selector Circuit

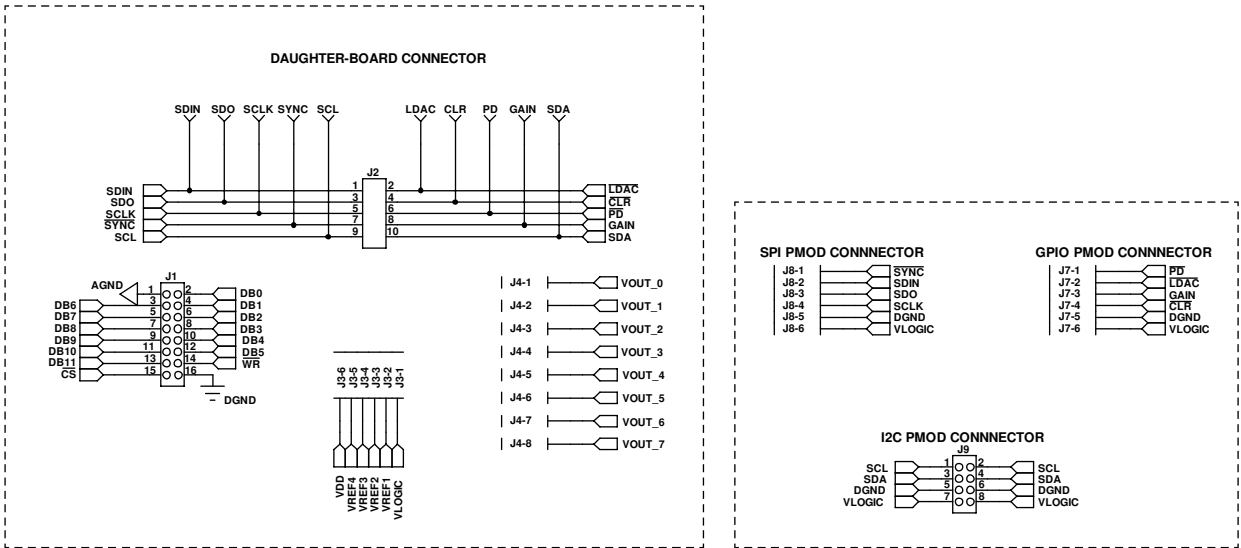

Figure 9. EVAL-MBnanoDAC-SDZ Motherboard Connectors to Daughter Board and Serial Interface

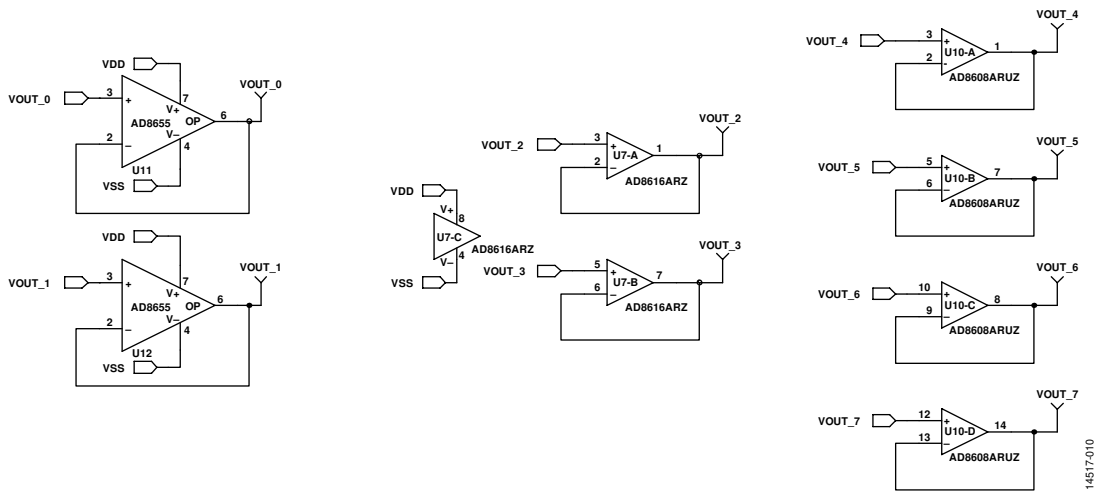

Figure 10. EVAL-MBnanoDAC-SDZ Motherboard Output Amplifier Circuit

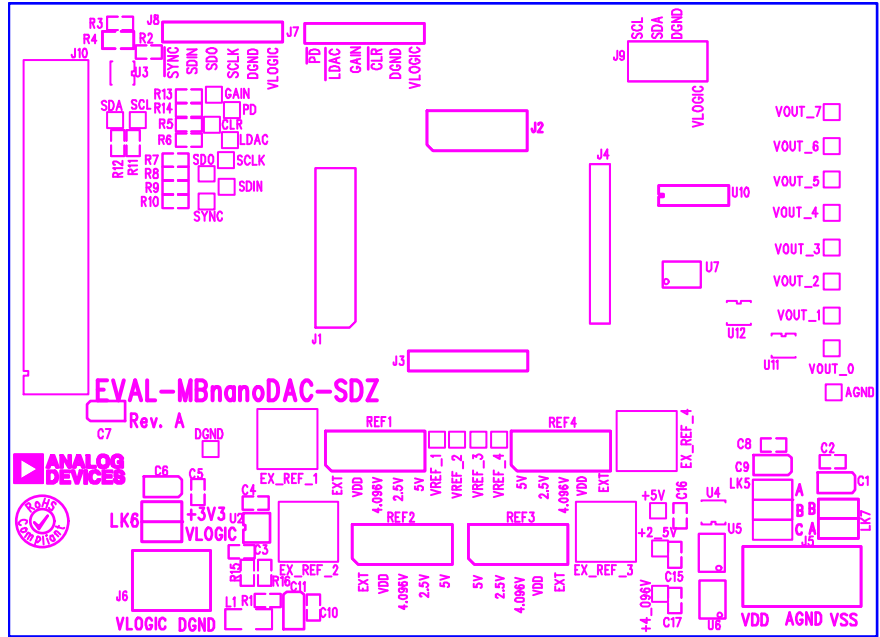

Figure 11. EVAL-MBnanoDAC-SDZ Motherboard Component Placement

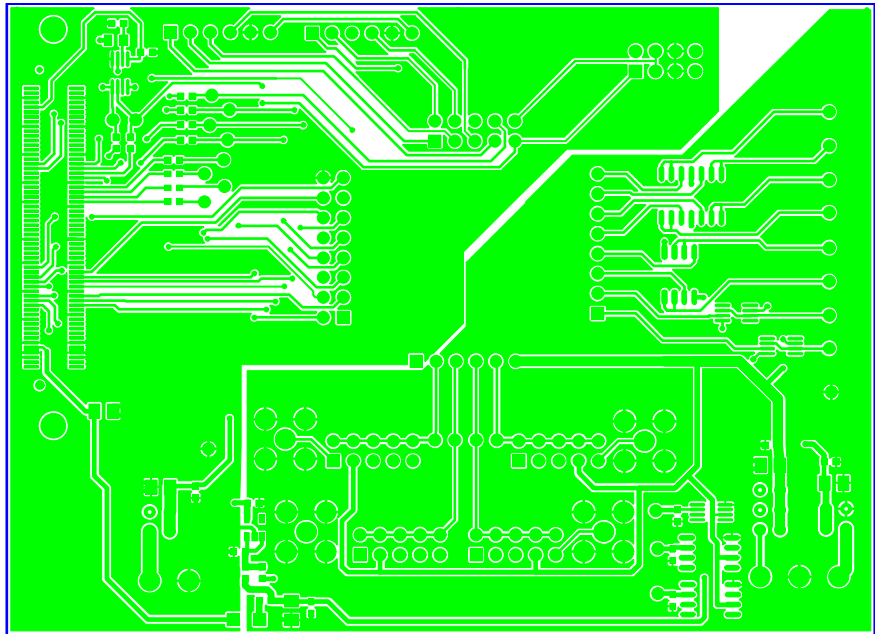

Figure 12. EVAL-MBnanoDAC-SDZ Motherboard Top Side Routing



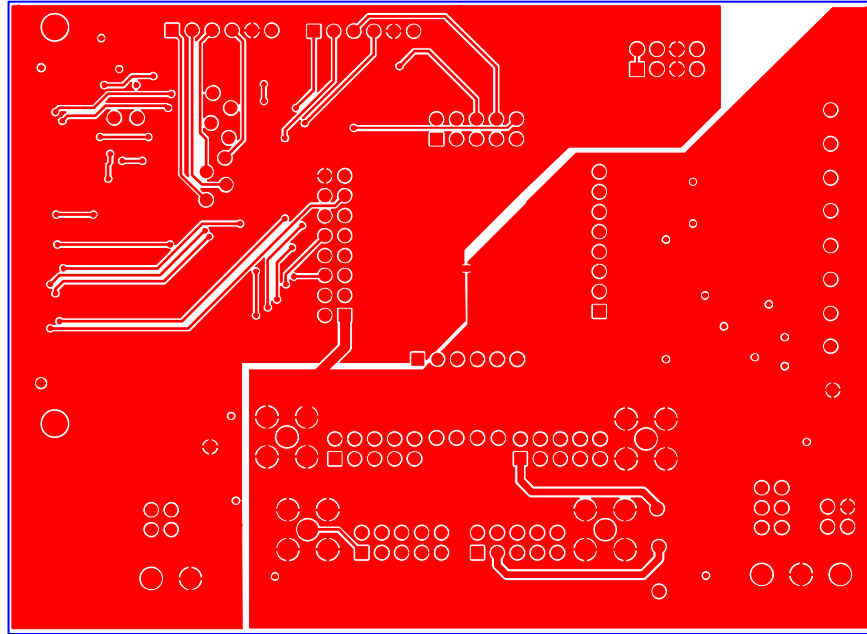

Figure 13. EVAL-MBnanoDAC-SDZ Motherboard Bottom Side Routing

**EVAL-AD5341DBZ DAUGHTER BOARD**

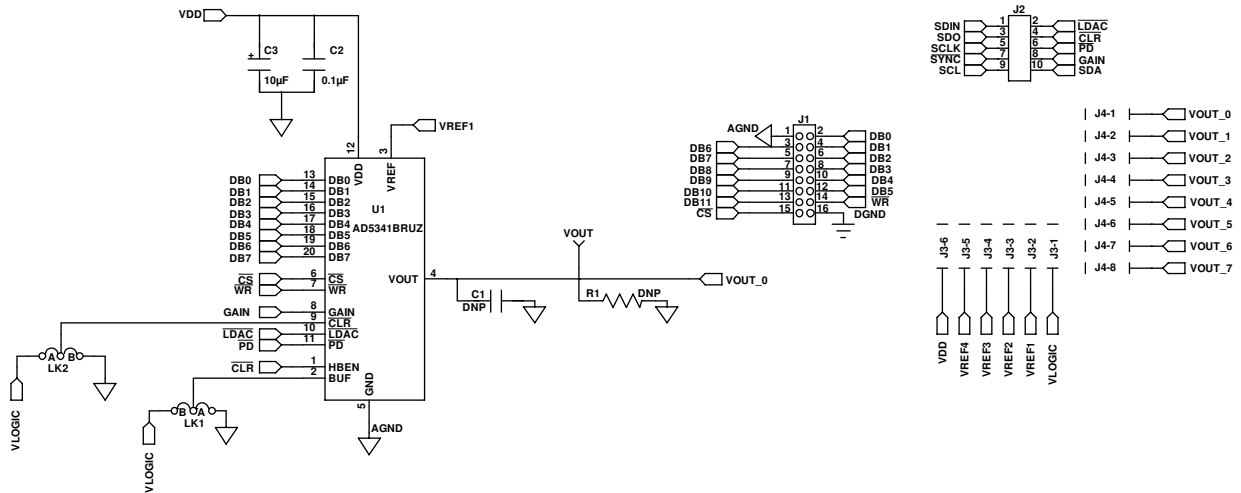
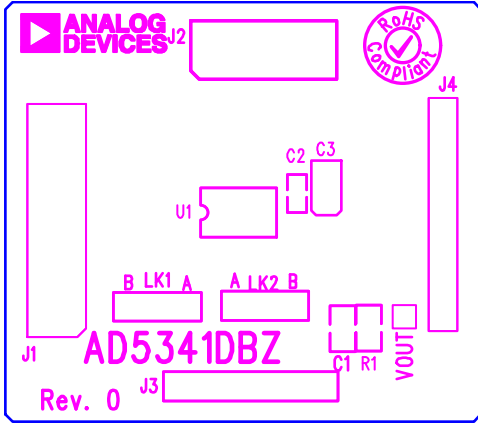
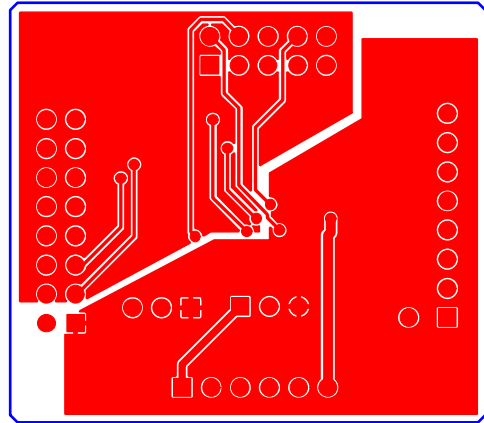

Figure 14. EVAL-AD5341DBZ Daughter Board Schematics



14517-015

Figure 15. EVAL-AD5341DBZ Daughter Board Component Placement



14517-017

Figure 17. EVAL-AD5341DBZ Daughter Board Bottom Side Routing

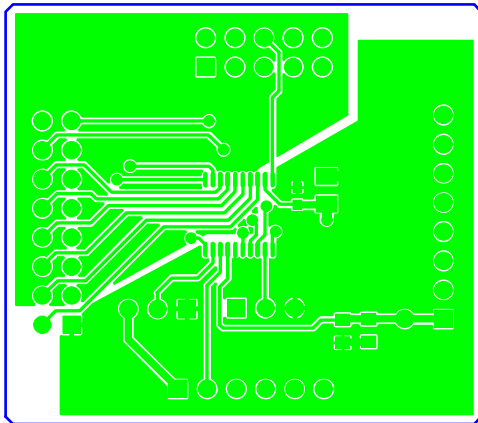

14517-016

Figure 16. EVAL-AD5341DBZ Daughter Board Top Side Routing

## ORDERING INFORMATION

### BILL OF MATERIALS

Table 5. Components List for the [EVAL-MBnanoDAC-SDZ](#) Motherboard

Quantity	Reference Designator	Description	Stock Code/Part Number <sup>1</sup>
4	C1, C6, C7, C9	6.3 V tantalum capacitors (Case A), 10 $\mu$ F, $\pm$ 20%	FEC 1190107
7	C2, C5, C8, C10, C15, C16, C17	50 V, X7R ceramic capacitors, 0.1 $\mu$ F, $\pm$ 10%	FEC 1759122
2	C3, C4	10 V, X5R ceramic capacitors, 1 $\mu$ F, $\pm$ 10%	GRM188R61A105KA61D <sup>2</sup>
1	C11	6.3 V tantalum capacitor (case A), 4.7 $\mu$ F, $\pm$ 20%	FEC 1432350
4	EXT_REF_1, EXT_REF_2, EXT_REF_3, EXT_REF_4	Straight PCB mount SMB jacks, 50 $\Omega$	FEC 1206013
1	J1	Header, 2.54 mm, 2 $\times$ 8-way	FEC 2308428
1	J2	Header, 2.54 mm, 2 $\times$ 5-way	FEC 9689583
3	J3, J7, J8	Headers, 2.54 mm, 1 $\times$ 6-way	FEC 9689508
1	J4	Header, 2.54 mm, 1 $\times$ 8-way	FEC 1766172
1	J5	3-pin terminal block	FEC 1667472
1	J6	2-pin terminal block	FEC 151789
1	J9	Header, 2.54 mm, 2 $\times$ 4-way	FEC 1667509
1	J10	120-way connector	FEC 1324660
1	L1	Inductor, SMD, 600 $\Omega$	FEC 9526862
1	LK5	6-pin (3 $\times$ 2), 0.1 inch header and shorting block	FEC 148-535 and 150-411 (36-pin strip)
2	LK6, LK7	4-pin (2 $\times$ 2), 0.1 inch headers and shorting blocks	FEC 148-535 and 150-411 (36-pin strip)
4	REF1, REF2, REF3, REF4	10-pin (5 $\times$ 2), 0.1 inch headers and shorting blocks	FEC 1022227 and 150-411
1	R1	Resistor, surge, 1.6 $\Omega$ , 1%, 0603	FEC 1627674
2	R2, R3	SMD resistors, 100 k $\Omega$ , 1%, 0603	FEC 9330402
11	R5, R6, R7, R8, R9, R10, R11, R12, R13, R14, R15	SMD resistors, 100 $\Omega$ , 1%, 0603	FEC 9330364
1	U2	3.3 V linear regulator	Analog Devices <a href="#">ADP121-AUJZ33R7</a>
1	U3	32 kb, I <sup>2</sup> C serial EEPROM	FEC 1331330
1	U4	5 V reference, 8-lead MSOP	Analog Devices <a href="#">ADR445ARMZ</a>
1	U5	Ultralow noise XFET <sup>®</sup> voltage reference	Analog Devices <a href="#">ADR431BRZ</a>
1	U6	4.096 V reference	Analog Devices <a href="#">REF198ESZ</a>
1	U7	Dual op amp	Analog Devices <a href="#">AD8616ARZ</a>
1	U10	Quad op amp	Analog Devices <a href="#">AD8608ARMZ</a>
2	U11, U12	Op amps	Analog Devices <a href="#">AD8655ARMZ</a>

<sup>1</sup> FEC refers to Farnell Electronic Component Distributors.<sup>2</sup> GRM refers to Murata Manufacturing Company.

Table 6. Components List for the EVAL-AD5341DBZ Daughter Board

Quantity	Reference Designator	Description	Stock Code/Part Number <sup>1</sup>
1	C1	Not applicable	Not inserted
1	C2	50 V, X7R ceramic capacitor 0.1 $\mu$ F, $\pm$ 10%	FEC 759122
1	C3	6.3 V tantalum capacitor (Case A), 10 $\mu$ F, $\pm$ 20%	FEC 1190107
1	J1	16-pin (2 $\times$ 8) header	FEC 2308428 inserted from solder side
1	J2	10-pin (2 $\times$ 5) straight header, 2.54 mm pitch	FEC 9689583 inserted from solder side
1	J3	6-pin (1 $\times$ 6) straight header, 2.54 mm pitch	FEC 9689508 inserted from solder side
1	J4	Header, 2.5 mm, PCB, 1 $\times$ 8-way	FEC 1766172 inserted from solder side
1	LK1	3-pin straight in line (SIL) header and shorting link	FEC 1022248 and 150-411
1	LK2	3-pin SIL header and shorting link	FEC 1022248 and 150-411
1	R1	Not applicable	Not inserted
1	U1	Single 12-bit DAC	Analog Devices AD5341BRUZ
1	V <sub>OUT</sub>	Red test point	Do not insert

<sup>1</sup> FEC refers to Farnell Electronic Component Distributors

<sup>1</sup>C refers to a communications protocol originally developed by Philips Semiconductors (now NXP Semiconductors).

**ESD Caution**

**ESD (electrostatic discharge) sensitive device.** Charged devices and circuit boards can discharge without detection. Although this product features patented or proprietary protection circuitry, damage may occur on devices subjected to high energy ESD. Therefore, proper ESD precautions should be taken to avoid performance degradation or loss of functionality.

**Legal Terms and Conditions**

By using the evaluation board discussed herein (together with any tools, components documentation or support materials, the "Evaluation Board"), you are agreeing to be bound by the terms and conditions set forth below ("Agreement") unless you have purchased the Evaluation Board, in which case the Analog Devices Standard Terms and Conditions of Sale shall govern. Do not use the Evaluation Board until you have read and agreed to the Agreement. Your use of the Evaluation Board shall signify your acceptance of the Agreement. This Agreement is made by and between you ("Customer") and Analog Devices, Inc. ("ADI"), with its principal place of business at One Technology Way, Norwood, MA 02062, USA. Subject to the terms and conditions of the Agreement, ADI hereby grants to Customer a free, limited, personal, temporary, non-exclusive, non-sublicensable, non-transferable license to use the Evaluation Board FOR EVALUATION PURPOSES ONLY. Customer understands and agrees that the Evaluation Board is provided for the sole and exclusive purpose referenced above, and agrees not to use the Evaluation Board for any other purpose. Furthermore, the license granted is expressly made subject to the following additional limitations: Customer shall not (i) rent, lease, display, sell, transfer, assign, sublicense, or distribute the Evaluation Board; and (ii) permit any Third Party to access the Evaluation Board. As used herein, the term "Third Party" includes any entity other than ADI, Customer, their employees, affiliates and in-house consultants. The Evaluation Board is NOT sold to Customer; all rights not expressly granted herein, including ownership of the Evaluation Board, are reserved by ADI. CONFIDENTIALITY. This Agreement and the Evaluation Board shall all be considered the confidential and proprietary information of ADI. Customer may not disclose or transfer any portion of the Evaluation Board to any other party for any reason. Upon discontinuation of use of the Evaluation Board or termination of this Agreement, Customer agrees to promptly return the Evaluation Board to ADI. ADDITIONAL RESTRICTIONS. Customer may not disassemble, decompile or reverse engineer chips on the Evaluation Board. Customer shall inform ADI of any occurred damages or any modifications or alterations it makes to the Evaluation Board, including but not limited to soldering or any other activity that affects the material content of the Evaluation Board. Modifications to the Evaluation Board must comply with applicable law, including but not limited to the RoHS Directive. TERMINATION. ADI may terminate this Agreement at any time upon giving written notice to Customer. Customer agrees to return to ADI the Evaluation Board at that time. LIMITATION OF LIABILITY. THE EVALUATION BOARD PROVIDED HEREUNDER IS PROVIDED "AS IS" AND ADI MAKES NO WARRANTIES OR REPRESENTATIONS OF ANY KIND WITH RESPECT TO IT. ADI SPECIFICALLY DISCLAIMS ANY REPRESENTATIONS, ENDORSEMENTS, GUARANTEES, OR WARRANTIES, EXPRESS OR IMPLIED, RELATED TO THE EVALUATION BOARD INCLUDING, BUT NOT LIMITED TO, THE IMPLIED WARRANTY OF MERCHANTABILITY, TITLE, FITNESS FOR A PARTICULAR PURPOSE OR NON-INFRINGEMENT OF INTELLECTUAL PROPERTY RIGHTS. IN NO EVENT WILL ADI AND ITS LICENSORS BE LIABLE FOR ANY INCIDENTAL, SPECIAL, INDIRECT, OR CONSEQUENTIAL DAMAGES RESULTING FROM CUSTOMER'S POSSESSION OR USE OF THE EVALUATION BOARD, INCLUDING BUT NOT LIMITED TO LOST PROFITS, DELAY COSTS, LABOR COSTS OR LOSS OF GOODWILL. ADI'S TOTAL LIABILITY FROM ANY AND ALL CAUSES SHALL BE LIMITED TO THE AMOUNT OF ONE HUNDRED US DOLLARS (\$100,000). EXPORT. Customer agrees that it will not directly or indirectly export the Evaluation Board to another country, and that it will comply with all applicable United States federal laws and regulations relating to exports. GOVERNING LAW. This Agreement shall be governed by and construed in accordance with the substantive laws of the Commonwealth of Massachusetts (excluding conflict of law rules). Any legal action regarding this Agreement will be heard in the state or federal courts having jurisdiction in Suffolk County, Massachusetts, and Customer hereby submits to the personal jurisdiction and venue of such courts. The United Nations Convention on Contracts for the International Sale of Goods shall not apply to this Agreement and is expressly disclaimed.