

FORCE (gf)		KNOB COLOR	Operating Life With Load
A	70±30	GREY	100,000 Cycles
H	100±30	WHITE	
0	130±30	GREY	
1	160±30	BLACK C/RED	
3	250±50	IVORY	50,000 Cycles

L	
A	3.15
B	3.85
C	5.85
D	8.35
E	6.85
F	6.15
G	12.35
H	11.35

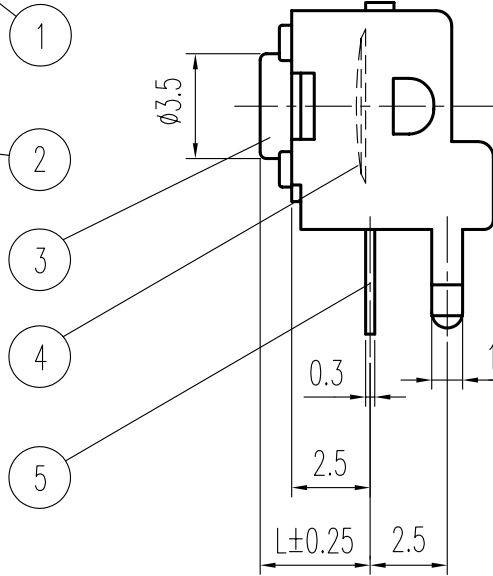
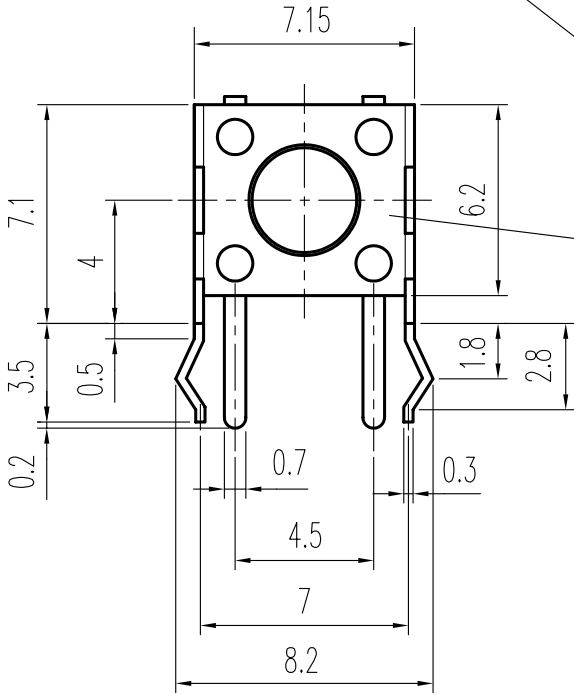

规格 Specifications

额定负荷 Ratings	DC 12_V 50_m A
初期接触电阻 Initial Contact Resistance	100_mΩ Max.
绝缘电阻 Insulation Resistance	DC100_V 60±5Sec. 100_MΩ Min.
抗电强度 Dielectric Voltage	AC 250_V (50~60HZ) 60±5 Sec.
操作力 Operating Force	见上表
负荷寿命 Operating Life With Load	见上表

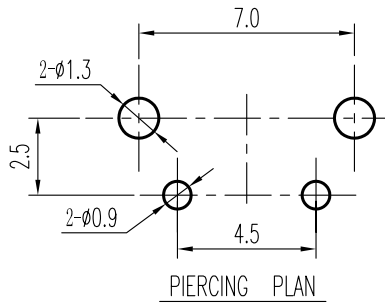
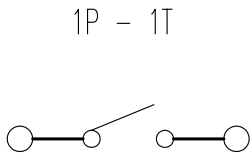

SCHMATIC

PIERCING PLAN

序NO.	零件 PART	材料 MATERIAL	数量 QTY	备注 REMARKS
5	端子 TERMINAL	C2680R	2	Ag PLATED
4	弹片 SPRING PLATE	C5210R	1	Ag CLAD
3	胶壳 HOUSING	P B T	1	BLACK C
2	盖片 COVER	S P T E	1	NATURAL
1	胶柄 KNOB	P B T	1	见附表

A03	ADD: 操作力为70gf的成品, 见标注 ①	杨静华	06-06-28
A02	ADD: 负荷寿命表栏 ② C5210R-EH/Ag CLAD → C5210R Ag CLAD 见③	刘红梅	06-04-01
A01	变更见 ④	王光荣	2006/2/10
03	变更见 ⑤	张德年	2003/9/23
标号 REV	内容 DESCRIPTION	签名 SIGN.	日期 DATE

DWG NO. ITEM1206

TOLERANCES UNLESS OTHERWISE SPEC.		TITLE	TACT SWITCH		ITEM NO	RS-022R	
UNDER 1	± 0.10	DRAWN	杨静华	06-06-28	VERSION	A03	PAGE 1 OF 1
1 - 10	± 0.30	REVIEWED	刘瑞富	06-06-28	SCALE		UNIT mm
OVER 10	± 0.50	APPROVED	林高全	06-06-30	PROJECTION		

COMAX ELECTRONICS (HUIZHOU) CO.,LTD.