

ENG. NO. SD 35711-04\*0

EDP NO.

SIMILAR ITEM

PROJECT NO.

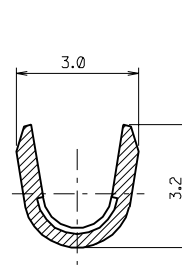
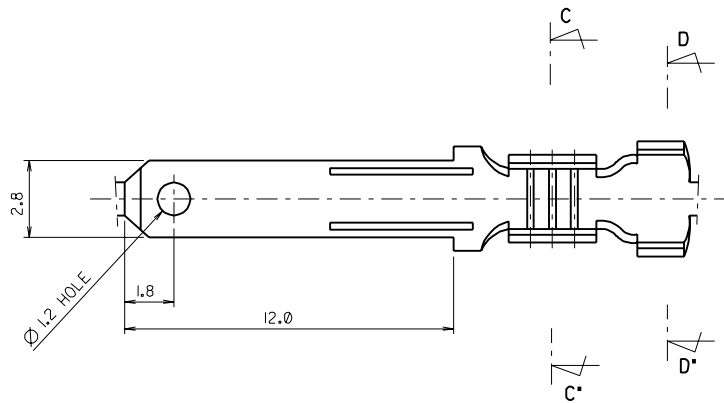

SECTION: C-C\*

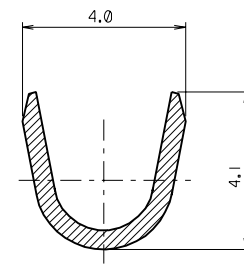

SECTION: D-D\*

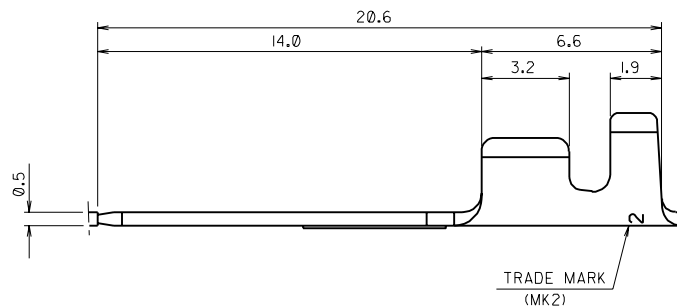

NOTES

- 1. MATERIAL: BRASS 0.5 THK'
- 2. PLATING: 35711-0400:UNPLATING  
35711-0410:POST-TIN PLATING

WIRE RANGE AWG #20-#16 (0.52-1.31 mm <sup>2</sup> )				MATERIAL	SEE NOTES		MOLEX-KOREA CO.,LTD.					
				GENERAL TOLERANCE DIMENSION : +0.3		DRAWN BY W.Y.YANG			CHK'D BY			
INSULATION RANGE Ø 1.8-2.3	B	REVISED	95-007	95.1.17	DIMENSION CLASSIFICATION		APP'D BY		SCALE		N/S	
	A	REDRAWN	92-007	92.1.31	▽ : CRITICAL ▾ : MAJOR ( ) : REFERENCE		TITLE :		SHEET		10F 1	
DIE FEED: //	LTR			REVISION RECORD	ECN	DATE	ASS'Y PART		.110 SLIP-ON TAB		REV A	
APPLICATOR FEED: 22.1	REVISE ONLY ON CAD SYSTEM						//	//	ENG. NO.		SD 35711-04*0	
O'TY/ REEL OR PACK 10,000 O'TY/REEL												