

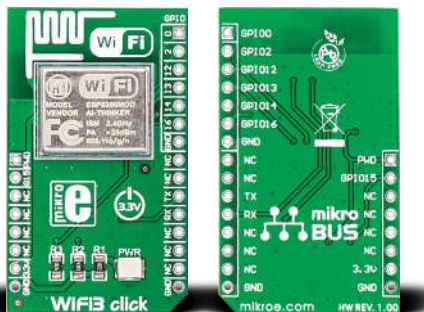

WiFi3 click™

1. Introduction



WiFi3 click™ is a complete self-contained WiFi solution carrying the **ESP8266MOD** module with a system on chip. The module has an integrated TCP/IP stack, supports Wi-Fi Direct (p2p) and boasts powerful processing and storage capabilities. Alongside a standard **mikroBUS™** socket, with WiFi3 click™ you'll have additional **6 GPIO pins at your disposal**. WiFi3 click™ communicates with the target board microcontroller through mikroBUS™ RX, TX, AN (PWD) and RST (G15) lines. The board uses a 3.3V power supply only.

2. Soldering the headers

Before using your click™ board, make sure to solder 1x8 male headers to both left and right side of the board. Two 1x8 male headers are included with the board in the package.

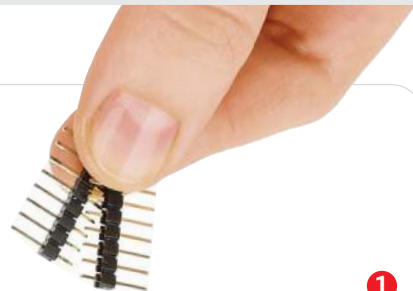

1

2



Turn the board upside down so that the bottom side is facing you upwards. Place shorter pins of the header into the appropriate soldering pads.

3

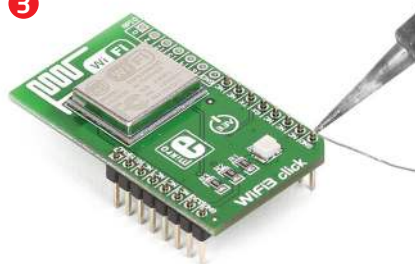

Turn the board upward again. Make sure to align the headers so that they are perpendicular to the board, then solder the pins carefully.

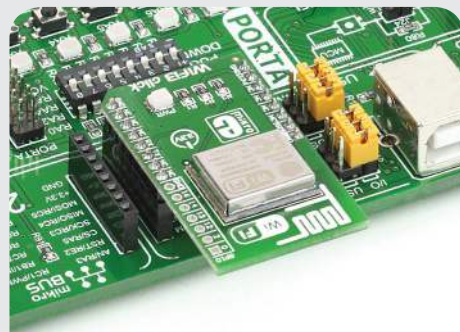

4. Essential features

WiFi3 click™ is ideally suited for **IoT applications**. The **System on Chip offloads all the networking functions from the MCU**. You can integrate it with sensors and actuators through its GPIOs and connect your things to the internet with minimum development effort. In place of standard mikroBUS™ AN and RST pins, WiFi3 click™ has PWD and G15 pins. These correspond to CH_PD and GPIO15 pins on the module. When you connect WiFi3 click™ to the mikroBUS™ socket, set the PWD pin to VCC and the G15 pin to GND, from within your code.

3. Plugging the board in

Once you have soldered the headers your board is ready to be placed into the desired mikroBUS™ socket. Make sure to align the cut in the lower-right part of the board with the markings on the silkscreen at the mikroBUS™ socket. If all the pins are aligned correctly, push the board all the way into the socket.

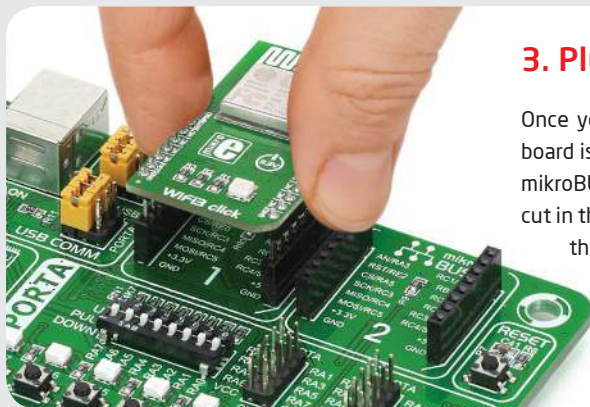

click™
BOARD
www.mikroe.com

WiFi3 click™ manual
ver. 1.00



0100000070468

5. WiFi3 click™ board schematic

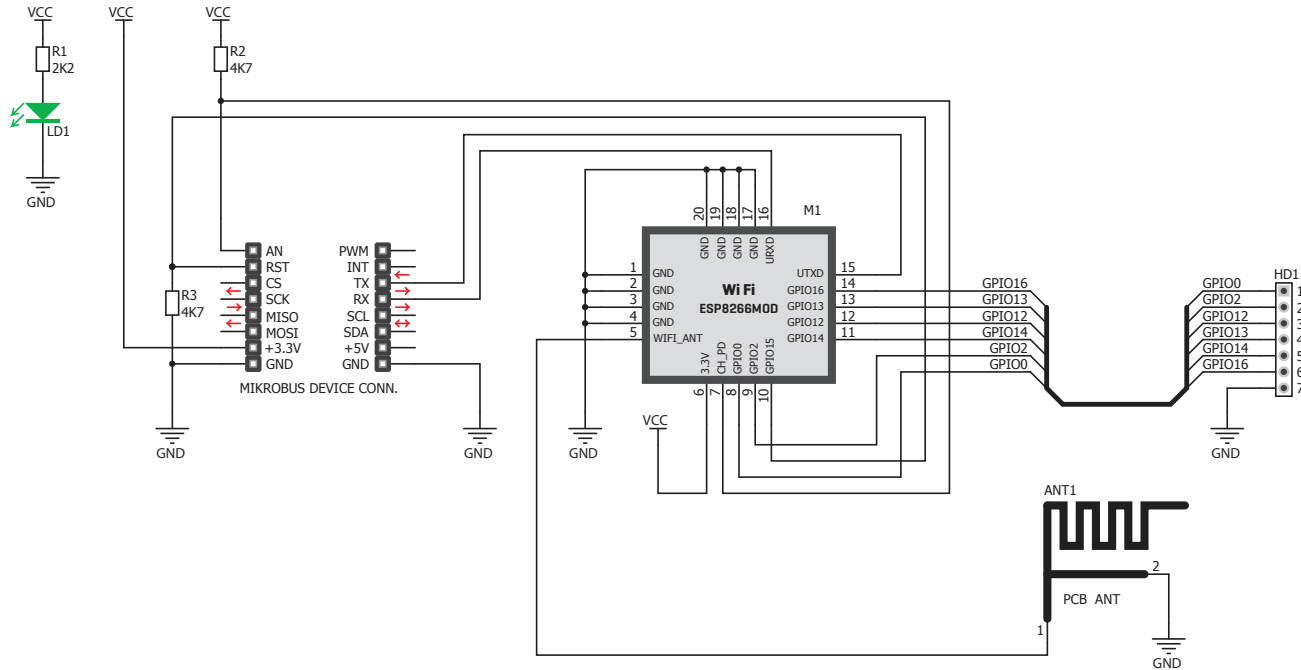

6. PCB antenna



WiFi3 click™ features a PCB trace antenna, designed for the 2400-2483.5 MHz frequency band.

7. Code examples

Once you have done all the necessary preparations, it's time to get your click™ board up and running. We have provided examples for mikroC™, mikroBasic™ and mikroPascal™ compilers on our **Libstock** website. Just download them and you are ready to start.



8. Support

MikroElektronika offers **free tech support** (www.mikroe.com/support) until the end of the product's lifetime, so if something goes wrong, we're ready and willing to help!