

THIS DRAWING IS UNPUBLISHED. RELEASED FOR PUBLICATION  
 © COPYRIGHT - TE Connectivity ALL RIGHTS RESERVED.

| REVISIONS |     |                           |           |     |      |
|-----------|-----|---------------------------|-----------|-----|------|
| P         | LTR | DESCRIPTION               | DATE      | DWN | APVD |
| N         |     | REV PER ECR 10-000722     | 25JAN10   | JR  | TM   |
| N1        |     | REVISED PER ECO-17-004099 | 23AUG2017 | RS  | DR   |

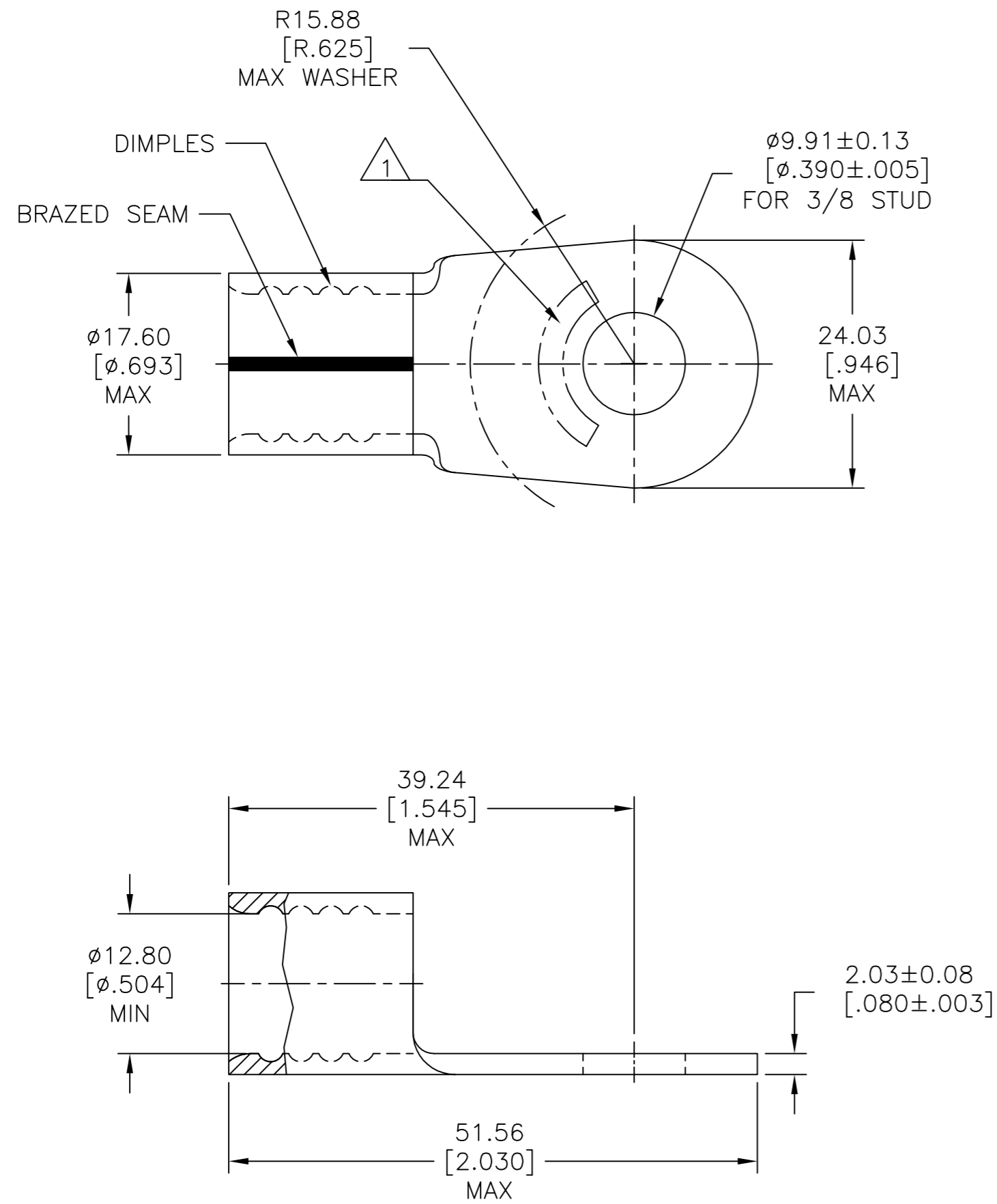

|                              |                     |                              |
|------------------------------|---------------------|------------------------------|
| <b>AMP</b><br>WIRE RANGE     | E13288<br>Listed    | LR7189<br>Certified          |
| 2/0 AWG<br>SOLID OR STRANDED | 2/0 AWG<br>STRANDED | 2/0 AWG<br>SOLID OR STRANDED |

- 1 STAMP AMP 2/0W\* APPROX AS SHOWN.
- 2 COPPER PER ASTM B-152, ANNEALED.
- 3 TIN PLATE 0.00254 [.000100] MIN THK EXT. PER ASTM B-545.
- 4 MAX RECOMMENDED OPERATING TEMP IS 170°C.
- 5 WIRE CROSS SECTIONAL AREA RANGE: 60.6-76.3mm [119,500-150,500] CMA SOLID OR STRANDED.

|     |                |          |
|-----|----------------|----------|
| 50  | LOOSE PIECE    | 36923    |
| QTY | PACKAGING TYPE | PART NO. |

|  |   |              |            |                  |  |
|--|---|--------------|------------|------------------|--|
| THIS DRAWING IS A CONTROLLED DOCUMENT.   |   | DWN          | DK_SCHRUM  | 1/14/94          | TE Connectivity<br>NAME<br>TERMINAL, RING TONGUE, SOLISTRAND |
| DIMENSIONS: mm [INCHES]  |   | CHK          | AJ KAUFMAN | 1/19/94          |  |
| TOLERANCES UNLESS OTHERWISE SPECIFIED:   |   | APVD         | JL MECKLEY | 1/19/94          |  |
| 0 PLC ± -<br>1 PLC ± -<br>2 PLC ± 0.20[.008]<br>3 PLC ± -<br>4 PLC ± -<br>ANGLES ± -<br>FINISH |   | PRODUCT SPEC | -          | APPLICATION SPEC |  |
| MATERIAL   | 2 | WEIGHT       | -          | SIZE             | A2   |
| CUSTOMER DRAWING   |   | SCALE        | 2:1        | CAGE CODE        | 00779  |
|  |   | SHEET        | 1 of 1     | DRAWING NO       | C=36923  |
|  |   | REV          | N1         | RESTRICTED TO    | -  |