

Three-Channel Charge Pump LED Driver

General Description

The AAT3193 is a charge-pump based, current-sink white LED driver capable of driving one to three LEDs up to 30mA, each. It automatically switches between 1x mode and 2x mode to maintain the highest efficiency and optimal LED current accuracy and matching.

The AAT3193 charge pump's 1x mode (bypass mode) has very low resistance allowing LED current regulation to be maintained with input supply voltage approaching the LED forward voltage.

The AAT3193 is available in a 2x2.2mm, 10-lead SC70JW-10 package.

Features

- Drives up to 3 LEDs at up to 30mA, each
- Automatic Switching Between 1x and 2x Modes
- 0.9MHz Switching Frequency
- Linear LED Output Current Control
 - Single-wire, S²Cwire Interface
 - AAT3193-1: 16-step
 - AAT3193-2: 8-step
 - AAT3193-3: 4-step
 - ON/OFF or PWM Interface
 - AAT3193-4
- ±10% LED Output Current Accuracy
- ±3% LED Output Current Matching
- Low-Current Shutdown Mode
- Built-in Thermal Protection
- Automatic Soft-Start
- Available in 2x2.2mm SC70JW-10 Package

Applications

- Entry Level Cordless Phone Handsets
- Entry Level Digital Cameras
- Entry Level Mobile Phone Handsets
- Entry Level MP3 and PMP Players

Typical Application

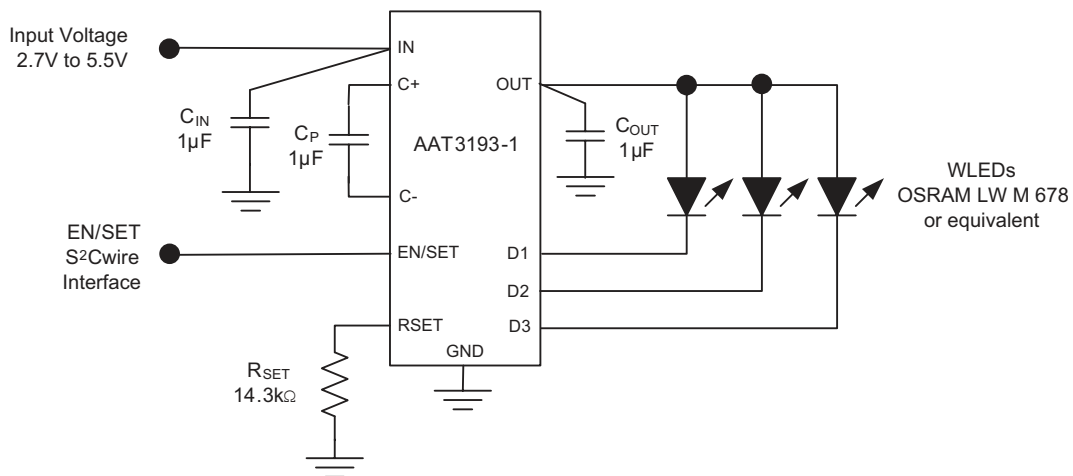

AAT3193

Three-Channel Charge Pump LED Driver

Pin Descriptions

Pin	Symbol	Description
1	D1	LED1 current sink input. D1 is the input of LED1 current sink. Connect LED1's anode to OUT and its cathode to D1.
2	OUT	Charge pump output. OUT is the output of the charge pump. Bypass OUT to GND with a 1 μ F or larger ceramic capacitor.
3	C-	Charge pump capacitor negative node.
4	C+	Charge pump capacitor positive node. Connect a 1 μ F ceramic capacitor between C+ and C-.
5	IN	Power source input. Connect IN to the power source, typically the battery. Bypass IN to GND with a 1 μ F or larger ceramic capacitor.
6	EN/SET (AAT3193-1/-2/-3)	LED enable and serial control input. EN/SET is the ON/OFF control for the LED and the S ² Cwire digital input for the AAT3193-1/-2/-3 to control serially the LED brightness according to the maximum current set by R _{SET} .
	EN/PWM (AAT3193-4)	LED ON/OFF and PWM control input. This logic input controls the LED outputs for the AAT3193-4. Alternatively, a PWM signal from a GPIO or an equivalent signal from a separate controller can be used to control LED output current linearly. A PWM signal, ranging from 10% to 100% duty cycle, controls the LED current linearly between ZS and FS.
7	RSET	A 1% tolerance resistor from this pin to GND sets the maximum LED current level. For optimal LED output current accuracy and matching in the AAT3193-1/-2/-4, a 14.3k Ω resistor sets each full-scale output current to 20mA, maximum. For the AAT3193-3, a 11.5k Ω resistor is recommended.
8	GND	Ground. Connect this pin to the system's ground plane.
9	D3	LED3 Current Sink Input. D3 is the input of LED3 current sink. Connect LED3's anode to OUT and its cathode to D3.
10	D2	LED2 Current Sink Input. D2 is the input of LED2 current sink. Connect LED2's anode to OUT and its cathode to D2.

Pin Configuration

SC70JW-10 (Top View)

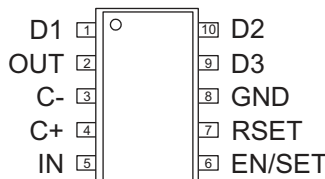

AAT3193**Three-Channel Charge Pump LED Driver****Part Number Descriptions**

Part Number	Interface	Current Control, Inverting
AAT3193IJQ-1	S ² Cwire	16-step
AAT3193IJQ-2	S ² Cwire	8-step
AAT3193IJQ-3	S ² Cwire	4-step
AAT3193IJQ-4	PWM	Linear

Absolute Maximum Ratings¹

Symbol	Description	Value	Units
	IN, C+, C-, OUT, D1, D2, D3, and RSET Pin Voltages to GND	-0.3 to 6.0	V
	EN/SET or EN/PWM Pin Voltage to GND	-0.3 to $V_{IN} + 0.3$	V
	Operating Junction Temperature Range	-40 to 150	°C
	Maximum Soldering Temperature (at leads, 10 sec)	300	°C

Thermal Information

Symbol	Description	Value	Units
P_D	Maximum Power Dissipation ^{2, 3}	625	mW
θ_{JA}	Maximum Thermal Resistance ²	160	°C/W

1. Stresses above those listed in Absolute Maximum Ratings may cause permanent damage to the device. Functional operation at conditions other than the operating conditions specified is not implied. Only one Absolute Maximum Rating should be applied at any one time.

2. Mounted on an FR4 circuit board.

3. Derate 6.25mW/°C above 40°C ambient temperature.

Three-Channel Charge Pump LED Driver**Electrical Characteristics¹**

IN = EN = 3.6V; C_{IN} = 1μF; C_{OUT} = 1μF; C_{CP} = 1μF; R_{SET} = 14.3kΩ; T_A = -40°C to 85°C unless otherwise noted. Typical values are at T_A = 25°C.

Symbol	Description	Conditions	Min	Typ	Max	Units
Input Power Supply						
IN	Input Voltage Range		2.7		5.5	V
I _{IN}	Input Operating Current	EN/SET or EN/PWM = IN; V _{D1} = V _{D2} = V _{D3} = IN, excluding I _{D1} -I _{D3}			0.6	mA
		EN/SET or EN/PWM = IN; I _{D1} = I _{D2} = I _{D3} = FS, excluding I _{D1} -I _{D3} ; V _{IN} - V _F = 1.5V			1.5	
		Operating, I _{D1} = I _{D2} = I _{D3} = FS; D1, D2 and D3 = OPEN			4.5	
I _{IN(SHDN)}	Input Shutdown Current	IN = 5.5V; EN/SET or EN/PWM = GND			1	μA
Charge Pump Section						
I _{OUT}	OUT Maximum Output Current			100		mA
f _{OSC}	Charge Pump Oscillator Frequency		0.65	0.9	1.15	MHz
V _{IN(TH)}	Charge Pump Mode Hysteresis	I _{D1} = I _{D2} = I _{D3} = 20mA; Excluding AAT3193-4, PWM Option		115	250	mV
t _{OUT}	Output Start-Up Time	EN/SET or EN/PWM = IN		150		μs
AAT3193-1/-2/-4: LED Current Sink Outputs						
I _{D(MAX)}	D1 - D3 Current Accuracy	DATA = 1; V _{IN} - V _F = 1.5V	18	20	22	mA
ΔI _{D(MAX)}	D1 - D3 Current Matching	DATA = 1; V _{IN} - V _F = 1.5V		±3		%
I _{D(DATA15)}	D1 - D3 Current Accuracy (AAT3193-1 only)	DATA = 15; V _{IN} - V _F = 1.5V	1.0	1.3	1.56	mA
I _{D(DATA8)}	D1 - D3 Current Accuracy (AAT3193-2 only)	DATA = 8; V _{IN} - V _F = 1.5V	1.0	1.3	1.56	mA
I _{D(10%)}	D1 - D3 Current Accuracy (AAT3193-4 only)	DC = 10%; f _{PWM} = 10kHz; V _{IN} - V _F = 1.5V		2.4		mA
V _{D(TH)}	D1- D3 Charge Pump Mode Transition Threshold	I _{D1} = I _{D2} = I _{D3} = 20mA		125		mV

1. The AAT3193 is guaranteed to meet performance specification over the -40°C to 85°C operating temperature range and is assured by design, characterization and correlation with statistical process controls.

Three-Channel Charge Pump LED Driver**Electrical Characteristics1**

IN = EN = 3.6V; C_{IN} = 1μF; C_{OUT} = 1μF; C_{CP} = 1μF; R_{SET} = 14.3kΩ; T_A = -40°C to 85°C unless otherwise noted. Typical values are at T_A = 25°C.

Symbol	Description	Conditions	Min	Typ	Max	Units
AAT3193-3: LED Current Sink Outputs						
I _{D(MAX)}	D1 - D3 Current Accuracy	R _{SET} = 11.5kΩ; DATA = 1; V _{IN} - V _F = 1.5V	18	20	22	mA
ΔI _{D(MAX)}	D1 - D3 Current Matching	R _{SET} = 11.5kΩ; DATA = 1; V _{IN} - V _F = 1.5V		±3		%
I _{D(DATA4)}	D1 - D3 Current Accuracy	R _{SET} = 11.5kΩ; DATA = 4; V _{IN} - V _F = 1.5V	0.72	0.9	1.1	mA
V _{D(TH)}	D1- D3 Charge Pump Mode Transition Threshold	R _{SET} = 11.5kΩ; I _{D1} = I _{D2} = I _{D3} = 20mA		125		mV
AAT3193-1/-2/-3: EN/SET and S²Cwire Control						
V _{ENH}	EN Input High Threshold Voltage		1.4			V
V _{ENL}	EN Input Low Threshold Voltage				0.4	V
I _{EN(LKG)}	EN Input Leakage Current	EN/SET = IN = 5V	-1		1	μA
t _{EN/SET(OFF)}	EN/SET Input OFF Timeout				500	μs
t _{EN/SET(LAT)}	EN/SET Input Latch Timeout				500	μs
t _{EN/SET(LOW)}	EN/SET Input LOW Time		0.3		75	μs
t _{ENSET(H-MIN)}	EN/SET Minimum High Time			50		ns
t _{ENSET(H-MAX)}	EN/SET Maximum High Time				75	μs
AAT3193-4: EN/PWM Current Control						
V _{ENH}	EN/PWM Input High Threshold Voltage		1.4			V
V _{ENL}	EN/PWM Input Low Threshold Voltage				0.4	V
I _{EN(LKG)}	EN/PWM Input Leakage Current	EN/PWM = IN = 5V	-1		1	μA
t _{PWM(ON)}	PWM Control Turn-on Delay			2		μs
t _{EN/PWM}	EN/PWM Input OFF Timeout		0.15		1	ms
f _{PWM}	PWM Control Frequency	Duty Cycle = 80%			50	kHz

1. The AAT3193 is guaranteed to meet performance specification over the -40°C to 85°C operating temperature range and is assured by design, characterization and correlation with statistical process controls.

AAT3193

Three-Channel Charge Pump LED Driver

Typical Characteristics

Operating Current (No Load) vs. Input Voltage

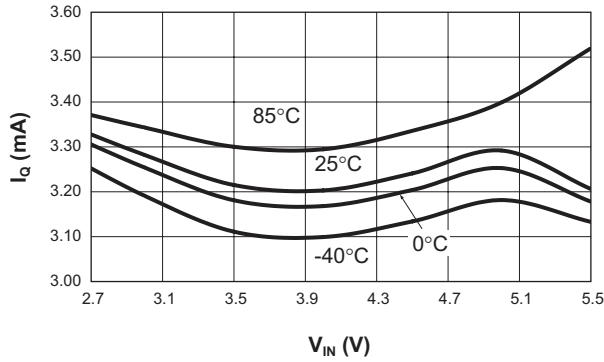

Shutdown Current vs. Temperature

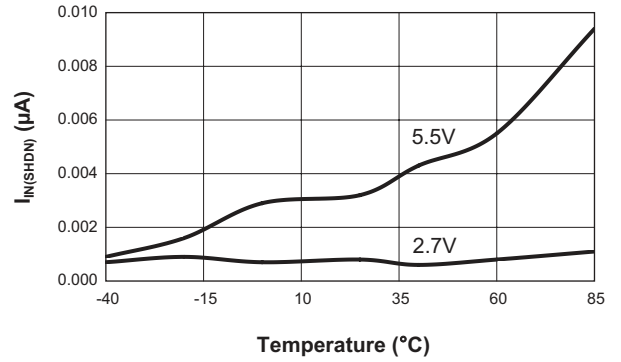

Efficiency vs. Input Voltage

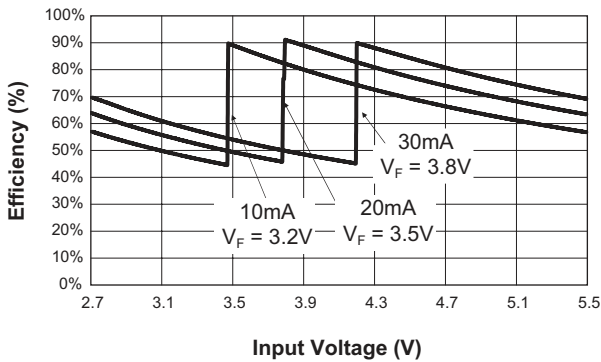

Current Matching vs. Temperature

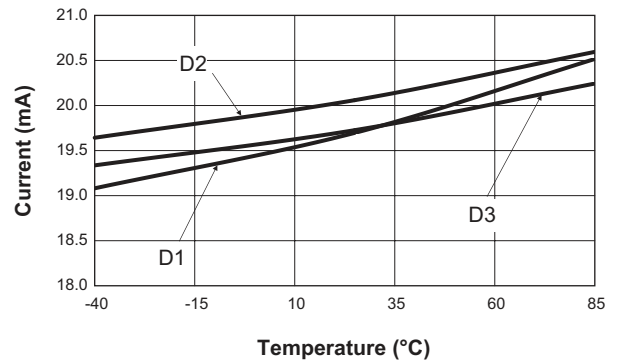

Turn On to 2X Mode (20mA/ch)

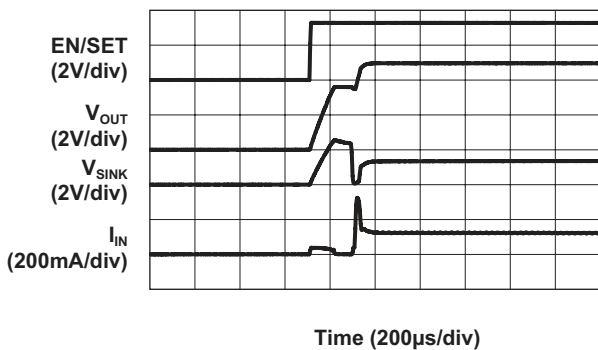

Turn Off from 2X Mode (20mA/ch)

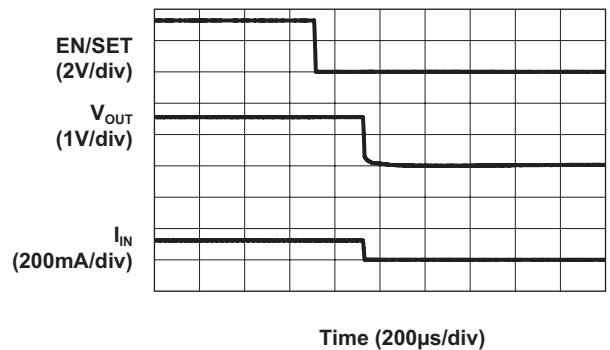

AAT3193

Three-Channel Charge Pump LED Driver

Typical Characteristics

Turn On to 1X Mode
($V_{IN} = 4.2V$; 20mA/ch)

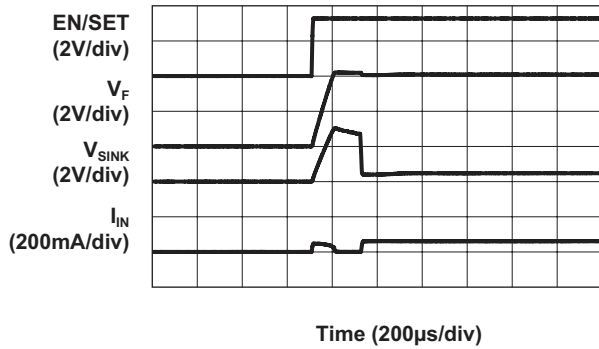

Maximum LED Current vs R_{SET}

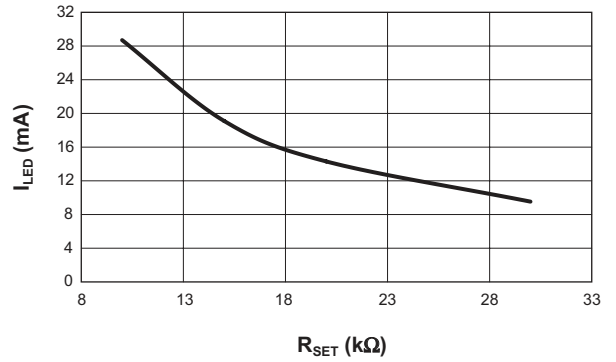

EN Input High Threshold Voltage vs. Input Voltage

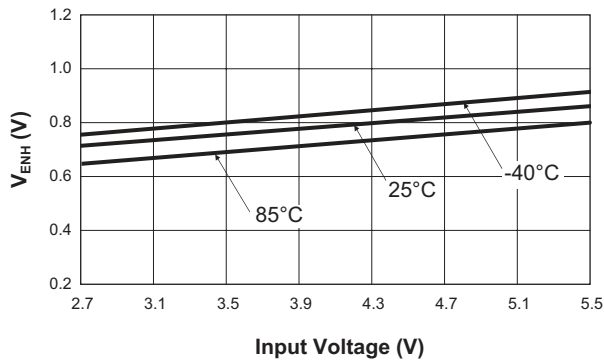

EN Input Low Threshold Voltage vs. Input Voltage

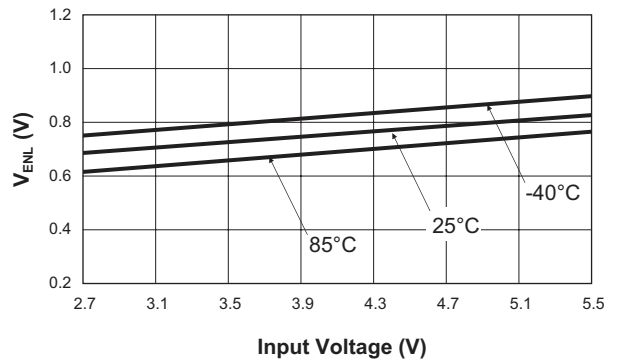

EN/SET Input Latch Timeout vs. Input Voltage

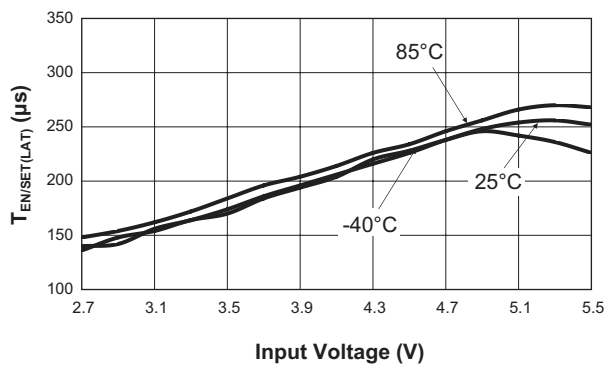

EN/SET Input OFF Timeout vs. Input Voltage

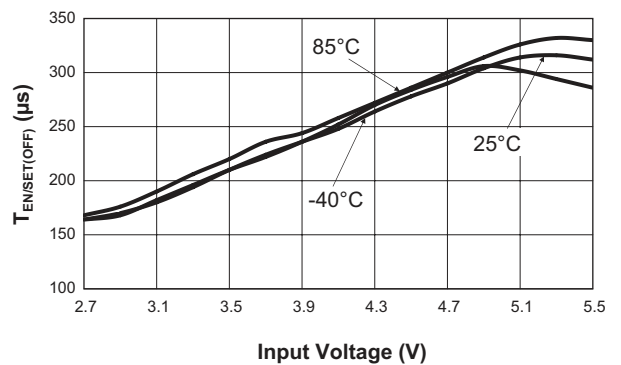

AAT3193

Three-Channel Charge Pump LED Driver

Typical Characteristics

Transition of LED Current
(20mA to 1.3mA)

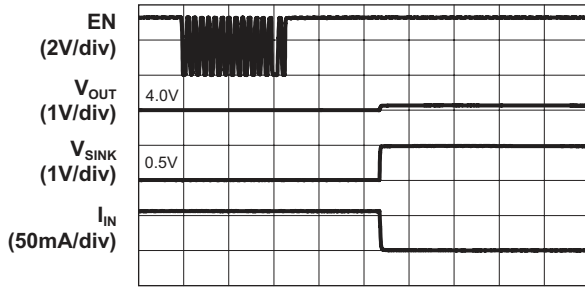

Time (100µs/div)

Transition of LED Current
(1.3mA to 20mA)

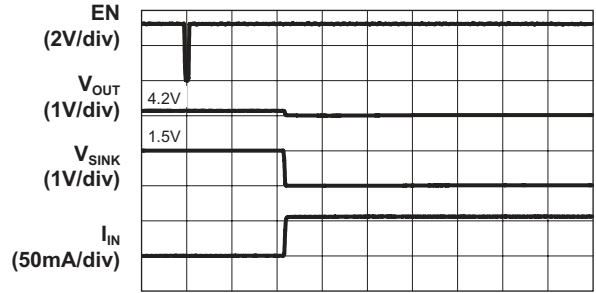

Time (100µs/div)

Output Ripple Waveform
(2X Mode; 20mA Load)

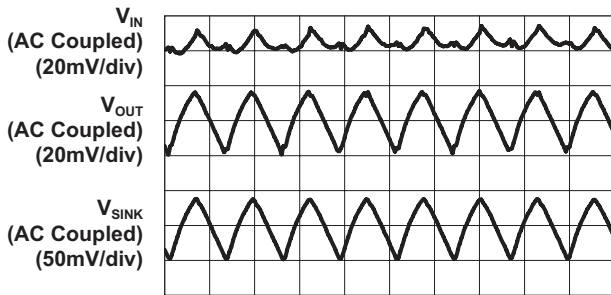

Time (1µs/div)

Input Current vs. Input Voltage
(Excluding AAT3193-4, PWM Option)

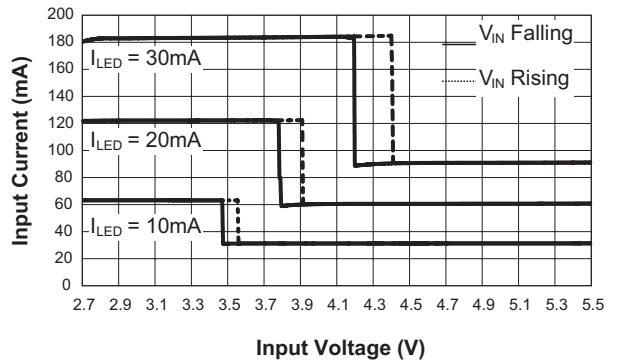

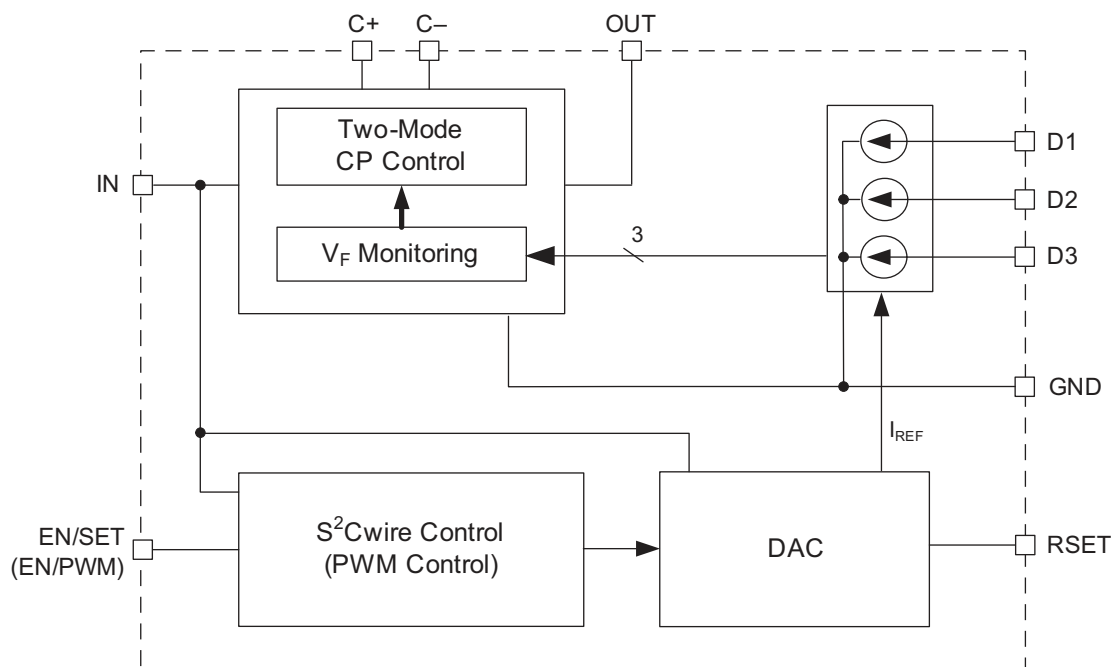
Functional Block Diagram**Functional Description**

The AAT3193 is a low-cost charge-pump solution designed to drive up to three white LEDs. The charge pump operates from a 2.7V to 5.5V power source and converts it to voltage levels necessary to drive the LEDs. LED current is individually controlled through integrated current sinks powered from the output of the charge pump. Low 1x charge-pump output resistance and low-drop voltage current sinks allow the charge pump to stay in 1x mode with an input voltage as low as 3.75V and LED forward voltages as high as 3.5V. Once in 2x mode, the AAT3193-1/-2/-3 continuously monitor the input supply voltage and automatically switch back to 1x mode when there is sufficient input voltage. To support fast PWM response, the 2x mode is latched in the AAT3193-4 and the device, once there, stays in that mode. To reset the AAT3193-4 to the 1x mode, strobe EN/PWM low for 1ms or longer.

The AAT3193 requires only four external components: one 1 μ F ceramic capacitor for the charge pump flying capacitors (C_P), one 1 μ F ceramic input capacitor (C_{IN}),

one 1 μ F ceramic output capacitor (C_{OUT}) and a resistor (R_{SET}) to set the maximum LED current. The three constant current outputs of the AAT3193 (D1 to D3) can drive three individual LEDs with a maximum current of 30mA each. Skyworks' S²Cwire serial Interface enables the AAT3193-1/-2/-3 and changes the current sink magnitudes through the EN/SET pin. The AAT3193-4 uses an external PWM signal to enable the IC and control the brightness of the LEDs.

Constant Current Control using R_{SET}

The maximum current is programmed by an external resistor at the RSET pin. Using a 14.3k Ω external resistor at the RSET pin, the AAT3193-1/-2/-4 includes an integrated serial LED current control that sets the full-scale LED current between 20mA and 0.63mA. For the AAT3193-3, a 11.5k Ω external resistor at the RSET pin sets the full-scale LED current between 20mA and 1.3mA. The full-scale LED current can set higher or lower than 20mA; see Table 5. For maximum accuracy, a 1% tolerance resistor is recommended.

AAT3193

Three-Channel Charge Pump LED Driver

S²Cwire Serial Interface (AAT3193-1/-2/-3 only)

The LED output current of the AAT3193 is controlled by Skyworks' S²Cwire serial interface. Since the LED current is programmable, no PWM or additional control circuitry is needed to control LED brightness. This feature greatly reduces the burden on a microcontroller or system IC to manage LED or display brightness, allowing the user to "set it and forget it." With its high-speed serial interface (1MHz data rate), the LED current can be changed quickly and easily. Also the non-pulsating LED current reduces system noise and improves LED reliability. The S²Cwire interface relies on the number of rising edges to the EN/SET pin to set the register. A typical write protocol is a burst of EN/SET rising edges, followed by a pause with EN/SET held high for at least t_{LAT} (500µs). The pro-

grammed current is then seen at the current sink outputs. When EN/SET is held low for an amount of time longer than t_{OFF} (500µs), the AAT3193 enters into shutdown mode and draws less than 1µA from the input and the internal data register is reset to zero.

The AAT3193-1/2/3's serial interface reduces the LED current on each rising pulse of the enable input. If the AAT3193 is in shutdown, the first rising edge of the EN/SET input turns on the LED driver to the maximum current. Successive rising edges decrease the LED current as shown in Table 1 and Figure 2 for the AAT3193-1. For the AAT3193-2, Table 2 and Figure 3 illustrate an 8-step LED current control profile. For the AAT3193-3, Table 3 and Figure 4 illustrate a 4-step LED current control profile.

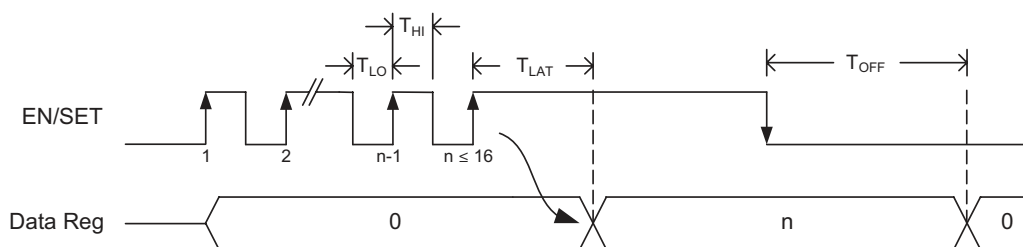

Figure 1: S²C Serial Interface Timing.

Data	EN Rising Edges	D1-D3 Current (mA)
1	1	20
2	2	18.7
3	3	17.3
4	4	16
5	5	14.7
6	6	13.3
7	7	12
8	8	10.7
9	9	9.3
10	10	8
11	11	6.7
12	12	5.3
13	13	4
14	14	2.7
15	15	1.3
16	16	0.63

Table 1: AAT3193-1 LED Current Settings.

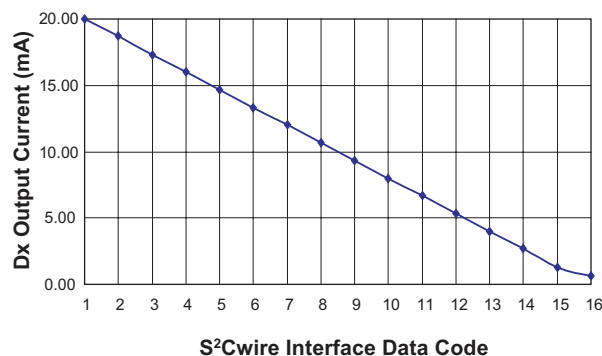

Figure 2: AAT3193-1 Current Control Profile.

AAT3193

Three-Channel Charge Pump LED Driver

Data	EN Rising Edges	D1-D3 Current (mA)
1	1	20
2	2	17.3
3	3	14.7
4	4	12
5	5	9.3
6	6	6.7
7	7	4
8	8	1.3

Table 2: AAT3193-2 LED Current Settings.

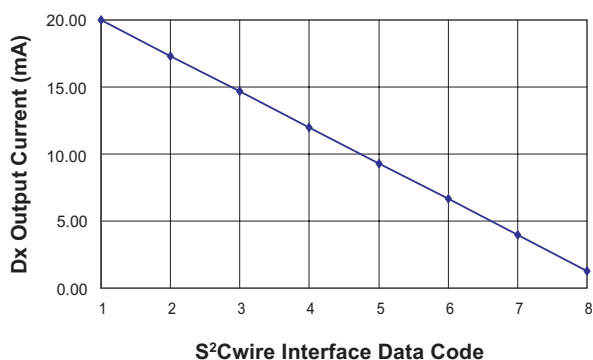

Figure 3: AAT3193-2 Current Control Profile.

Data	EN Rising Edges	D1-D3 Current (mA)
1	1	20
2	2	13.3
3	3	6.7
4	4	0.87

Table 3: AAT3193-3 LED Current Settings.

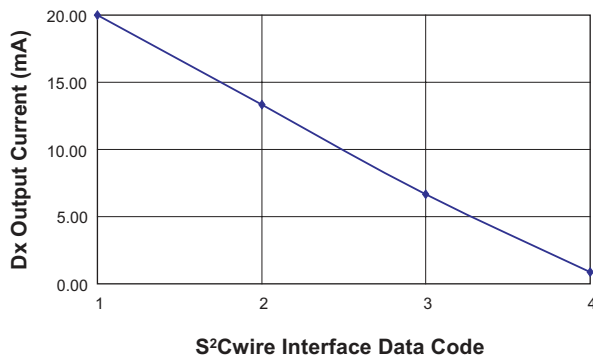

Figure 4: AAT3193-3 Current Control Profile.

PWM Control (AAT3193-4 only)

PWM (Pulse Width Modulation) is an industry standard technique of controlling LED brightness by modulating the conduction duty cycle of the LED current. LED brightness is determined by the average value of the PWM signal multiplied by the LED's intensity where intensity is proportional to the LED drive current. A PWM control signal can be applied into the EN/PWM pin of the AAT3193-4. By changing the duty cycle of the PWM signal from 100% (logic high) to 10%, LEDs sink current can be programmed from 20mA to 2.4mA. To save power when not used, AAT3193-4 can be shutdown by holding the EN/PWM pin low for 1ms.

Lastly, Table 4 and Figure 5 illustrate the AAT3193-4's LED current control profile as a function of a PWM control signal.

EN/PWM Duty Cycle	D1-D3 Current (mA)
100%	20
90%	17.9
80%	15.9
70%	14
60%	12.1
50%	10.1
40%	8.2
30%	6.3
20%	4.3
10%	2.4

Table 4: AAT3193-4 LED Current Settings
($R_{SET} = 14.3k\Omega$, $f_{PWM} = 50kHz$).

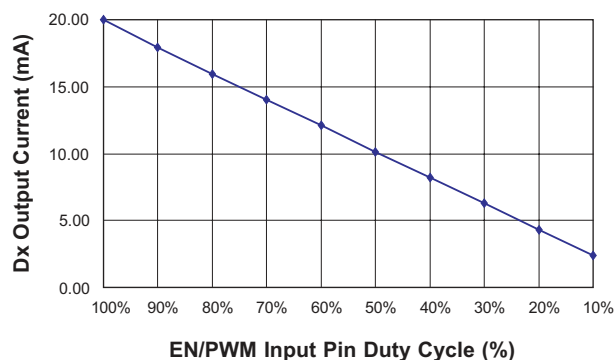

Figure 5: AAT3193-4 Current Control Profile
($R_{SET} = 14.3k\Omega$, $f_{PWM} = 50kHz$).

Three-Channel Charge Pump LED Driver**Applications Information****LED Selection**

The AAT3193 is specifically intended for driving white LEDs. However, the device design will allow the AAT3193 to drive most types of LEDs with forward voltage specifications ranging from 2.2V to 4.7V. LED applications may include mixed arrangements for display backlighting, keypad display, and any other application needing a constant current sink generated from a varying input voltage. Since the D1 to D3 constant current sinks are matched with negligible supply voltage dependence, the constant current channels will be matched regardless of the specific LED forward voltage (V_F) levels.

The low dropout current sinks in the AAT3193 maximize performance and make it capable of driving LEDs with high forward voltages. Multiple channels can be combined to obtain a higher LED drive current without complication.

Constant Current Setting

The LED current is controlled by the R_{SET} resistor. For maximum accuracy, a 1% tolerance resistor is recommended. Table 5 shows R_{SET} resistor values for AAT3193-1/2/4 and Table 6 shows R_{SET} resistor values for AAT3193-3 for various LED full-scale current levels.

I_{LED} (mA)	R_{SET} (K Ω)
30	9.53
20	14.3
15	19.1
10	28.7

Table 5: Maximum LED Current and R_{SET} Resistor Values (1% Resistor Tolerance) for the AAT3193-1/2/4.

I_{LED} (mA)	R_{SET} (K Ω)
30	7.68
20	11.5
15	15.4
10	23.2

Table 6: Maximum LED Current and R_{SET} Resistor Values (1% Resistor Tolerance) for the AAT3193-3.

Device Switching Noise Performance

The AAT3193 operates at a fixed frequency of approximately 1MHz to control noise and limit harmonics that can interfere with the RF operation of mobile communication devices. Back-injected noise appearing on the input pin of the charge pump is 20mV peak-to-peak, typically ten times less than inductor-based DC/DC boost converter white LED backlight solutions. The AAT3193 soft-start feature prevents noise transient effects associated with inrush currents during start-up of the charge pump circuit.

Shutdown

Since the current switches are the only power returns for all loads, there is no leakage current when all sink switches are disabled. To activate the shutdown operation, the EN/SET input for the AAT3193-1/2/3 should be strobed low for longer than t_{OFF} (500 μ s). For the 3193-4 PWM options, shutdown operation is enabled when the EN/PWM input is strobed low longer than 1ms. In this state, the AAT3193 typically draws less than 1 μ A from the input. Registers are reset to 0 in shutdown.

Power Efficiency and Device Evaluation

The charge pump efficiency discussion in the following sections accounts only for efficiency of the charge pump section itself. Due to the unique circuit architecture and design of the AAT3193, it is very difficult to measure efficiency in terms of a percent value comparing input power over output power.

Since the AAT3193 outputs are pure constant current sinks and typically drive individual loads, it is difficult to measure the output voltage for a given output to derive an overall output power measurement. For any given application, white LED forward voltage levels can differ, yet the output drive current will be maintained as a constant.

This makes quantifying output power a difficult task when taken in the context of comparing to other white LED driver circuit topologies. A better way to quantify total device efficiency is to observe the total input power to the device for a given LED current drive level. The best white LED driver for a given application should be based on trade-offs of size, external component count, reliability, operating range, and total energy usage...*not just % efficiency.*

AAT3193

Three-Channel Charge Pump LED Driver

The AAT3193 efficiency may be quantified under very specific conditions and is dependent upon the input voltage versus the output voltage across the loads applied to outputs D1 through D3 for a given constant current setting. Depending on the combination of V_{IN} and voltages sensed at the current sinks, the device will operate in load switch mode. When any one of the voltages sensed at the current sinks nears dropout, the device will operate in 2X charge pump mode. Each of these modes will yield different efficiency values. Refer to the following two sections for explanations for each operational mode.

1X Mode Efficiency

The AAT3193 1X mode is operational at all times and functions alone to enhance device power conversion efficiency when V_{IN} is higher than the voltage across the load. When in 1X mode, voltage conversion efficiency is defined as output power divided by input power.

An expression for the ideal efficiency (η) in 1X charge-pump mode can be expressed as:

$$\eta = \frac{P_{OUT}}{P_{IN}} = \frac{V_F \cdot I_{LED}}{V_{IN} \cdot I_{OUT}} \cong \frac{V_F}{V_{IN}}$$

-or-

$$\eta (\%) = 100 \cdot \left(\frac{V_F}{V_{IN}} \right)$$

2X Charge Pump Mode Efficiency

The AAT3193 contains a charge pump which will boost the input supply voltage in the event where V_{IN} is less than the voltage required to supply the output. The efficiency (η) can be simply defined as a linear voltage regulator with an effective output voltage that is equal to one and two times the input voltage. Efficiency (η) for an ideal 2X charge pump can typically be expressed as the output power divided by the input power.

$$\eta = \frac{P_F}{P_{IN}}$$

In addition, with an ideal 2X charge pump, the output current may be expressed as 1/3 of the input current. The expression to define the ideal efficiency (η) can be rewritten as:

$$\eta = \frac{P_{OUT}}{P_{IN}} = \frac{V_F \cdot I_{LED}}{V_{IN} \cdot 2I_{OUT}} = \frac{V_F}{2V_{IN}}$$

-or-

$$\eta (\%) = 100 \cdot \left(\frac{V_F}{2V_{IN}} \right)$$

For a charge pump with an output of 5V and a nominal input of 3.5V, the theoretical efficiency is 71%. Due to internal switching losses and IC quiescent current consumption, the actual efficiency can be measured at 51%. Efficiency will decrease substantially as load current drops below 1mA or when the voltage level at V_{IN} approaches the voltage level at V_{OUT} .

Additional Applications

The current sinks of the AAT3193 can be combined to drive higher current levels through a single LED. As an example, a single LED can be driven at 90mA total by combining together the D1-D3 outputs.

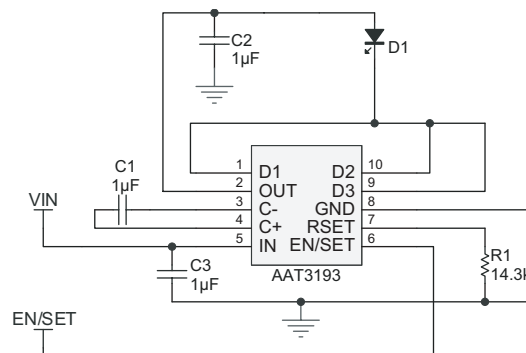

Figure 6: Higher Current, Single LED Application.

For lower-cost applications, the flying capacitor can be removed. This will force the AAT3193 to operate in 1X mode. To maintain regulated LED current, the input supply voltage has to be higher than the charge-pump's dropout voltage in 1X mode.

AAT3193

Three-Channel Charge Pump LED Driver

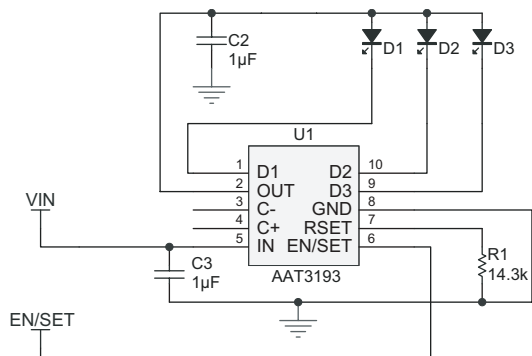

Figure 7: Lower Cost 1X Mode Application.

Capacitor Selection

Careful selection of the three external capacitors C_{IN} , C_P , and C_{OUT} is important because they will affect turn-on time, output ripple, and transient performance. Optimum performance will be obtained when low equivalent series resistance (ESR) ceramic capacitors are used; in general, low ESR may be defined as less than 100m Ω . A value of 1 μ F for all four capacitors is a good starting point when choosing capacitors. If the constant current sinks are only programmed for light current levels, then the capacitor size may be decreased.

Capacitor Characteristics

Ceramic composition capacitors are highly recommended over all other types of capacitors for use with the AAT3193. Ceramic capacitors offer many advantages over their tantalum and aluminum electrolytic counterparts. A ceramic capacitor typically has very low ESR, is

lowest cost, has a smaller PCB footprint, and is non-polarized. Low ESR ceramic capacitors help maximizing charge pump transient response. Since ceramic capacitors are non-polarized, they are not prone to incorrect connection damage.

Equivalent Series Resistance

ESR is an important characteristic to consider when selecting a capacitor. ESR is a resistance internal to a capacitor that is caused by the leads, internal connections, size or area, material composition, and ambient temperature. Capacitor ESR is typically measured in milliohms for ceramic capacitors and can range to more than several ohms for tantalum or aluminum electrolytic capacitors.

Ceramic Capacitor Materials

Ceramic capacitors less than 0.1 μ F are typically made from NPO or COG materials. NPO and COG materials generally have tight tolerance and are very stable over temperature. Larger capacitor values are usually composed of X7R, X5R, Z5U, or Y5V dielectric materials. Large ceramic capacitors (i.e., larger than 2.2 μ F) are often available in low cost Y5V and Z5U dielectrics, but capacitors larger than 1 μ F are not typically required for AAT3193 applications.

Capacitor area is another contributor to ESR. Capacitors that are physically large will have a lower ESR when compared to an equivalent material smaller capacitor. These larger devices can improve circuit transient response when compared to an equal value capacitor in a smaller package size.

AAT3193

Three-Channel Charge Pump LED Driver

Evaluation Board Layout

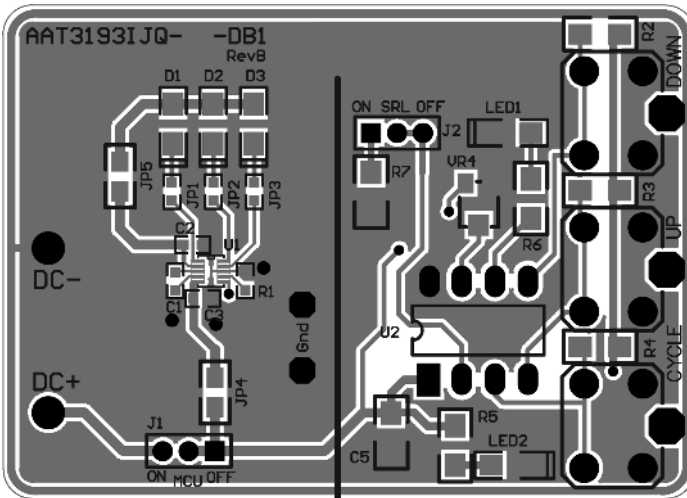

Figure 9: AAT3193 Evaluation Board Component Side Layout.

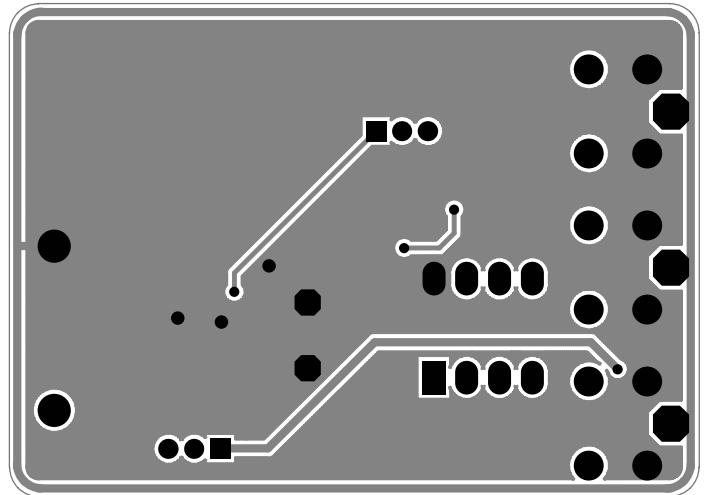

Figure 10: AAT3193 Evaluation Board Solder Side Layout.

AAT3193

Three-Channel Charge Pump LED Driver

Ordering Information

Package	Interface	Current Control, Inverting	Marking ¹	Part Number (Tape and Reel) ²
SC70JW-10	S ² Cwire	16-step	XGXY	AAT3193IJQ-1-T1
SC70JW-10	S ² Cwire	8-step		AAT3193IJQ-2-T1
SC70JW-10	S ² Cwire	4-step		AAT3193IJQ-3-T1
SC70JW-10	PWM	Linear	ZHXY	AAT3193IJQ-4-T1



Skyworks Green™ products are compliant with all applicable legislation and are halogen-free. For additional information, refer to *Skyworks Definition of Green™*, document number SQ04-0074.

Package Information

SC70JW-10

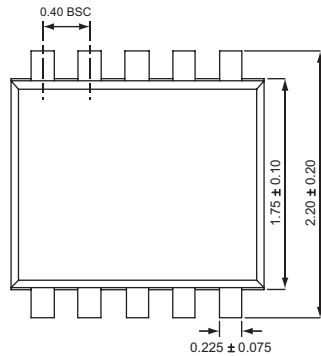

Top View

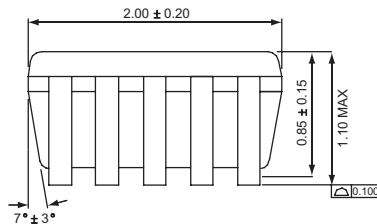

Side View

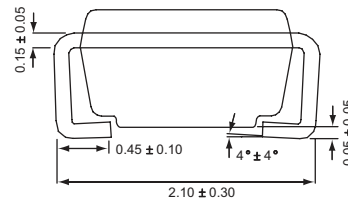

End View

All dimensions in millimeters.

1. XYY = assembly and date code.
2. Sample stock is generally held on part numbers listed in **BOLD**.

Three-Channel Charge Pump LED Driver

Copyright © 2012 Skyworks Solutions, Inc. All Rights Reserved.

Information in this document is provided in connection with Skyworks Solutions, Inc. ("Skyworks") products or services. These materials, including the information contained herein, are provided by Skyworks as a service to its customers and may be used for informational purposes only by the customer. Skyworks assumes no responsibility for errors or omissions in these materials or the information contained herein. Skyworks may change its documentation, products, services, specifications or product descriptions at any time, without notice. Skyworks makes no commitment to update the materials or information and shall have no responsibility whatsoever for conflicts, incompatibilities, or other difficulties arising from any future changes.

No license, whether express, implied, by estoppel or otherwise, is granted to any intellectual property rights by this document. Skyworks assumes no liability for any materials, products or information provided hereunder, including the sale, distribution, reproduction or use of Skyworks products, information or materials, except as may be provided in Skyworks Terms and Conditions of Sale.

THE MATERIALS, PRODUCTS AND INFORMATION ARE PROVIDED "AS IS" WITHOUT WARRANTY OF ANY KIND, WHETHER EXPRESS, IMPLIED, STATUTORY, OR OTHERWISE, INCLUDING FITNESS FOR A PARTICULAR PURPOSE OR USE, MERCHANTABILITY, PERFORMANCE, QUALITY OR NON-INFRINGEMENT OF ANY INTELLECTUAL PROPERTY RIGHT; ALL SUCH WARRANTIES ARE HEREBY EXPRESSLY DISCLAIMED. SKYWORKS DOES NOT WARRANT THE ACCURACY OR COMPLETENESS OF THE INFORMATION, TEXT, GRAPHICS OR OTHER ITEMS CONTAINED WITHIN THESE MATERIALS. SKYWORKS SHALL NOT BE LIABLE FOR ANY DAMAGES, INCLUDING BUT NOT LIMITED TO ANY SPECIAL, INDIRECT, INCIDENTAL, STATUTORY, OR CONSEQUENTIAL DAMAGES, INCLUDING WITHOUT LIMITATION, LOST REVENUES OR LOST PROFITS THAT MAY RESULT FROM THE USE OF THE MATERIALS OR INFORMATION, WHETHER OR NOT THE RECIPIENT OF MATERIALS HAS BEEN ADVISED OF THE POSSIBILITY OF SUCH DAMAGE.

Skyworks products are not intended for use in medical, lifesaving or life-sustaining applications, or other equipment in which the failure of the Skyworks products could lead to personal injury, death, physical or environmental damage. Skyworks customers using or selling Skyworks products for use in such applications do so at their own risk and agree to fully indemnify Skyworks for any damages resulting from such improper use or sale.

Customers are responsible for their products and applications using Skyworks products, which may deviate from published specifications as a result of design defects, errors, or operation of products outside of published parameters or design specifications. Customers should include design and operating safeguards to minimize these and other risks. Skyworks assumes no liability for applications assistance, customer product design, or damage to any equipment resulting from the use of Skyworks products outside of stated published specifications or parameters.

Skyworks, the Skyworks symbol, and "Breakthrough Simplicity" are trademarks or registered trademarks of Skyworks Solutions, Inc., in the United States and other countries. Third-party brands and names are for identification purposes only, and are the property of their respective owners. Additional information, including relevant terms and conditions, posted at www.skyworksinc.com, are incorporated by reference.