



500 MHz LC Bandpass Filter

Part Number: AE500B11158



Electrical Specifications

Center Frequency: 500 MHz
Bandwidth: 150 MHz
Passband at -3dB: 425-575 MHz
Insertion Loss at Fo: 0.8 dB Max
Rejection on Lowside of Pb: 60 dB @ 270 MHz
Rejection on Highside of Pb: 60 dB @ 840 MHz
Power Handling: +33 dBm

Mechanical

Connector Type: SMA (F)
Dimensions: 1.5 x 0.5 x 0.4 Inches

Environmental

Operating Temperature: -30 to +75° C
Storage Temperature: -30 to +85° C

Outline Drawing:

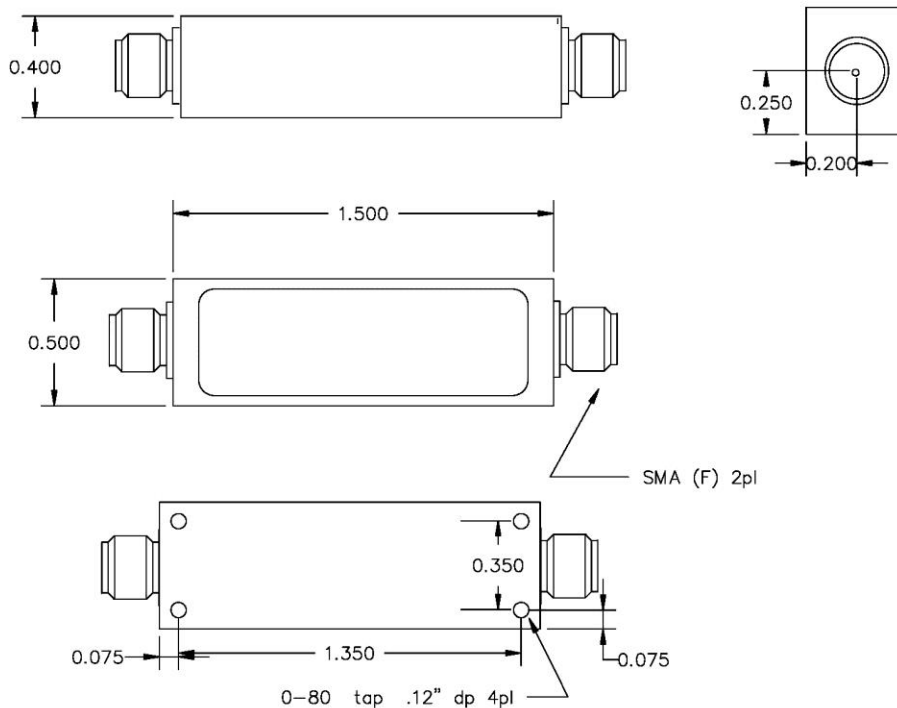

Rev. Date	Anatech Electronics Inc		
	TITLE Case & Cover		
	SIZE	GRADE CODE	DWG NO
	emb 5/20/10	OK0R2	9869790D
	SCALE		REV



500 MHz LC Bandpass Filter

Part Number: AE500B11158



Response Plot:

A435.lad

OCT 12, 2014

Attenuation/Return Loss

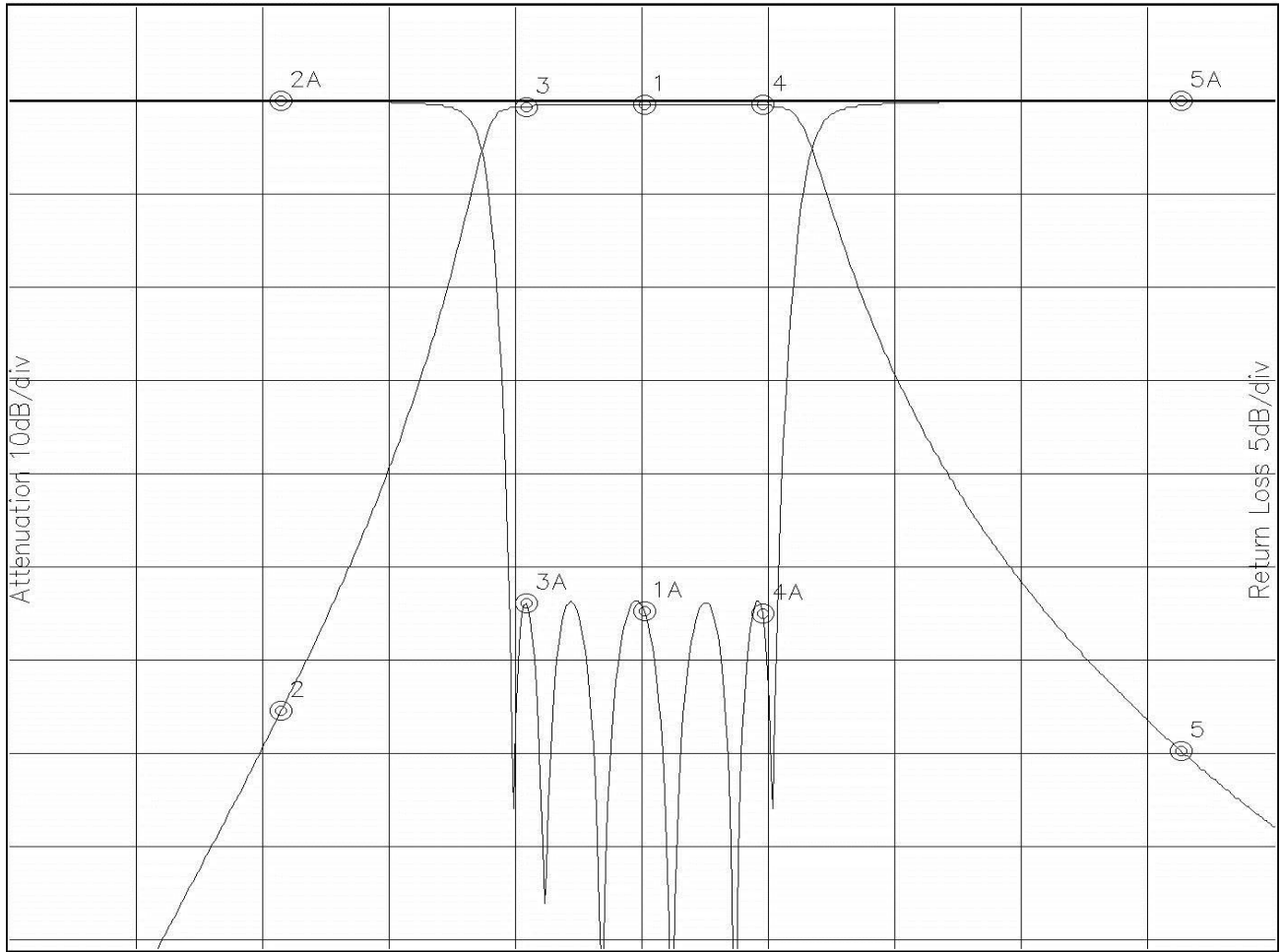

Attenuation Start: 100.0MHz Stop: 900.0MHz

Return Loss Start: 100.0MHz Stop: 900.0MHz

Marker 1 Freq 500.64MHz Atten -0.391dB
 Marker 2 Freq 270.59MHz Atten -65.322dB
 Marker 3 Freq 425.68MHz Atten -0.578dB
 Marker 4 Freq 575.60MHz Atten -0.502dB
 Marker 5 Freq 840.54MHz Atten -69.525dB

Marker 1A Freq 500.64MHz Ret Loss -27.313dB
 Marker 2A Freq 270.59MHz Ret Loss 0.000dB
 Marker 3A Freq 425.68MHz Ret Loss -26.868dB
 Marker 4A Freq 575.60MHz Ret Loss -27.441dB
 Marker 5A Freq 840.54MHz Ret Loss 0.000dB