

REFERENCE SPECIFICATIONS

-NFC 93425 (in compliance with HE 501)

PHYSICAL CHARACTERISTICS

-INSULATOR MATERIAL: THERMOPLASTIC UL94 V-0
 -CONTACT MATERIAL: PHOSPHOR BRONZE
 GOLD OVER NICKEL

-ACCESSORIES: BRASS,cadmium plated yellow passivation
 -SHELLS: STEEL,cadmium plated yellow passivation

ELECTRICAL CHARACTERISTICS

-NOMINAL CURRENT: 7.5A
 -CONTACT RESISTANCE: <= 7.3 m ohms
 -CONTACT/CONTACT : >=1000 V
 -CONTACT/GROUND : >=1200 V
 -INSULATION RESISTANCE: >=5000 MOhms

ENVIRONMENTAL CHARACTERISTICS

- CLIMATIC CATEGORY: 55/125/56
 TEMPERATURE RANGE -55°C TO +125°C
 DAMP HEAT STEADY STATE 56 DAYS
 SALT SPRAY 48 HOURS

MECHANICAL CHARACTERISTICS

- RETENTION AGAINST TORQUE: - Threaded insert: 0.7 N.m minimum
 - Female screw : 0.5 N.m minimum

Series **DBML25S043**

Shell size: **E A B C D**
 see sheet 2

Front accessory definition
 see sheet 2

- Blank** :without accessory
- F** :floating mounting
- L** :threaded insert M3
- O** :threaded insert UNC 4-40
- V** :female screw UNC 4-40
- I** :female screw M3

Contact number (see sheet 2)
9,15,25,37,50

Contacts
S :Socket

Plating
Blank :solder bucket 500 matings/unmatings
043 :solder bucket 500 matings/unmatings
 for harsh environment

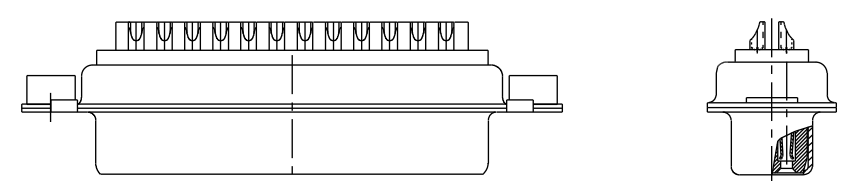

25 WAY for Example

Copyright FCI.



www.fciconnect.com				surface ISO 1302	-	tolerance std ISO 406	ISO 1101	projection ISO 1101	mm	
				TOLERANCES UNLESS OTHERWISE SPECIFIED						
Dr	M PESSON	2006/11/14		ANGULAR		0.X	±0.3	size	A2	
Eng	P LEGARE	2006/11/14		LINEAR		0.XX	±0.1	Scale	2:1	
Chr	P LEGARE	2006/11/14		0° ±2°		0.XXX	±0.05	ECN	LS07-0273	
Appr	P LEGARE	2006/11/14		Product family				- Spec ref		
rev	ecn no	dr	date							
A	LS06-0174	MPE	2006/11/14							
B	LS07-0217	MLE	2007/08/22							
C	LS07-0273	MPE	2007/10/30							
D	F10-0072	LSA	2010/07/20							
				title SUB FEMALE DM HE501 series with solder bucket catalog no				dwg no C01-8637-1733 sheet 1 of 4		Rev. D

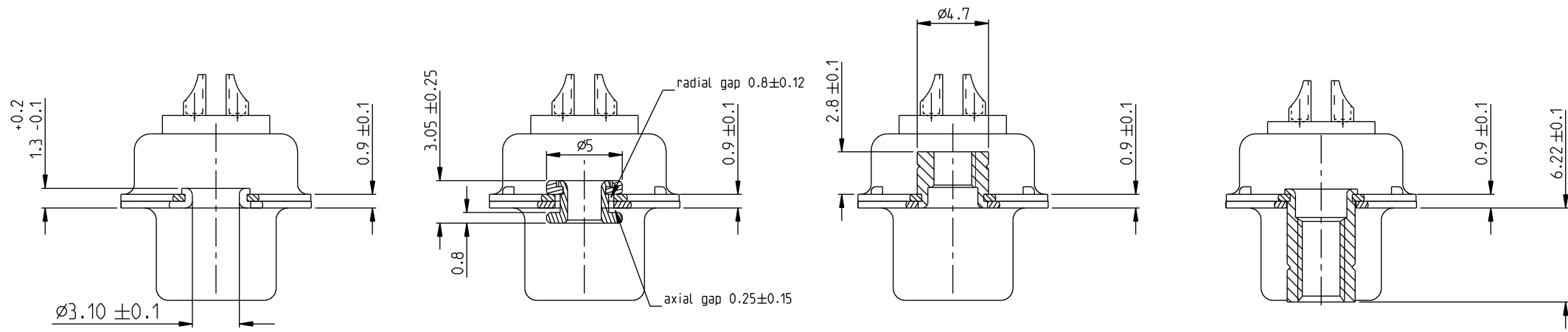

FRONT ACCESSORY	Blank without	F floating mounting	L insert M3 O insert UNC 4.40	V female screw UNC 4.40 I female screw M3
-----------------	----------------------	----------------------------	--	--

PART NUMBER	FRONT ACCESSORY
D*MxxS	without
D*MFxxS	floating mounting
D*MLxxS	insert M3
D*MOxxS	insert UNC 4.40
D*MVxxS	female screw UNC 4.40
D*MIxxS	female screw M3

shell size	Contact number
*	XX
E	09
A	15
B	25
C	37
D	50

PART NUMBER	FRONT ACCESSORY
D*MxxS043	without
D*MFxxS043	floating mounting
D*MLxxS043	insert M3
D*MOxxS043	insert UNC 4.40
D*MVxxS043	female screw UNC 4.40
D*MIxxS043	female screw M3

CROSS REFERENCES HE501 and FC1

HE501 P/N	FC1 P/N	FRONT ACCESSORY
HE501NxxAS	D*MxxS	without
HE501FxxAS	D*MFxxS	floating mounting

www.fciconnect.com		surface ISO 1302	- ✓	tolerance std ISO 406	ISO 1101	projection A2	mm
		TOLERANCES UNLESS OTHERWISE SPECIFIED				Scale 2:1	
Dr	M PESSON	2006/11/14	ANGULAR	0.X	±0.3	size	A2
Eng	P LEGARE	2006/11/14	LINEAR	0.XX	±0.1	ECN	LS07-0273
Chr	P LEGARE	2006/11/14	0° ±2°	0.XXX	±0.05	Product family	- Spec ref
Appr	P LEGARE	2006/11/14					
FCI title		SUB FEMALE DM HE501 series		dwg no		C01-8637-1733	
		with solder bucket		Rev.		D	
catalog no		-		CUSTOMER		sheet 2 of 4	

SCALE:4

Copyright FCI.

DIMENSIONS FOR SHELL E,A,B,C

Dimensions are in millimeters

Shell size	Number of contacts	A ^{+0.76} ₋₀	B ^{+0.25} ₋₀	C ± 0.12	F ^{+0.57} ₋₀	G ^{+0.25} ₋₀	H ^{+0.51} ₋₀
E	09	30.43	16.21	24.99	10.64	6.05	19.02
A	15	38.76	24.54	33.32	10.64	6.05	27.25
B	25	52.65	38.25	47.04	10.64	6.05	41.02
C	37	68.94	54.71	63.50	10.64	6.05	57.45

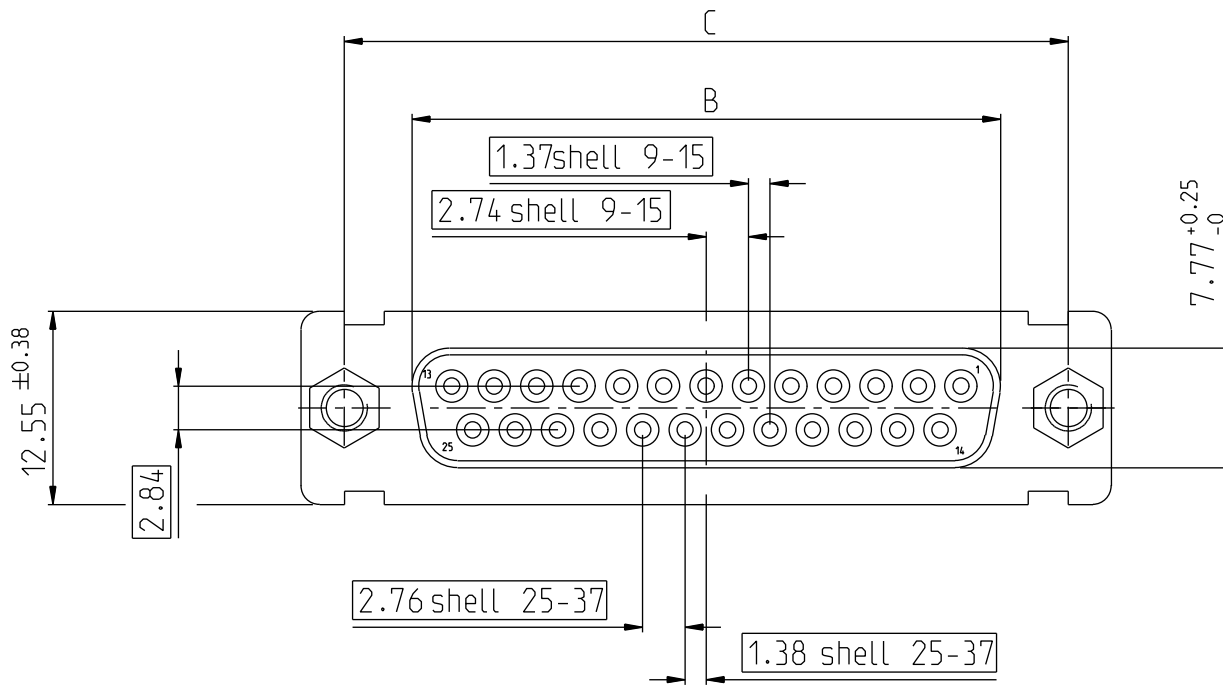
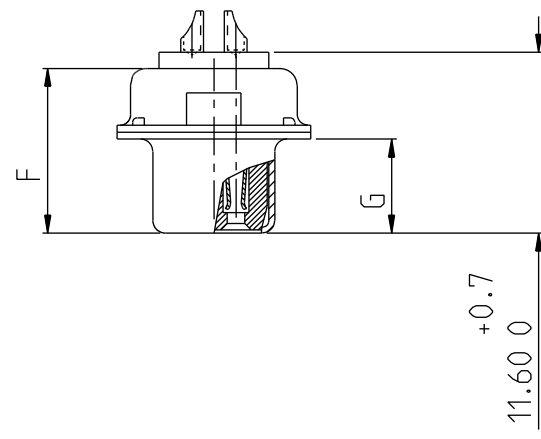
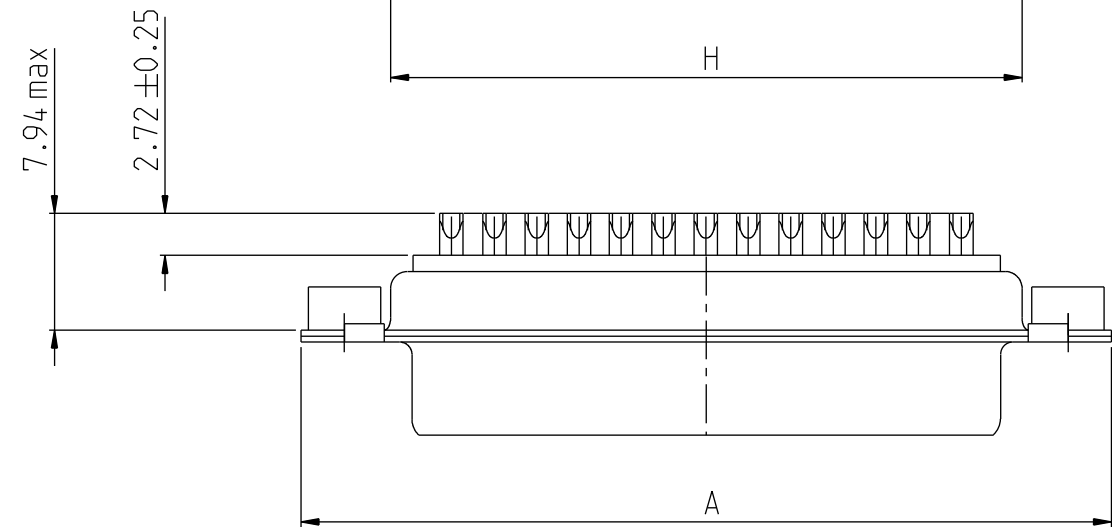
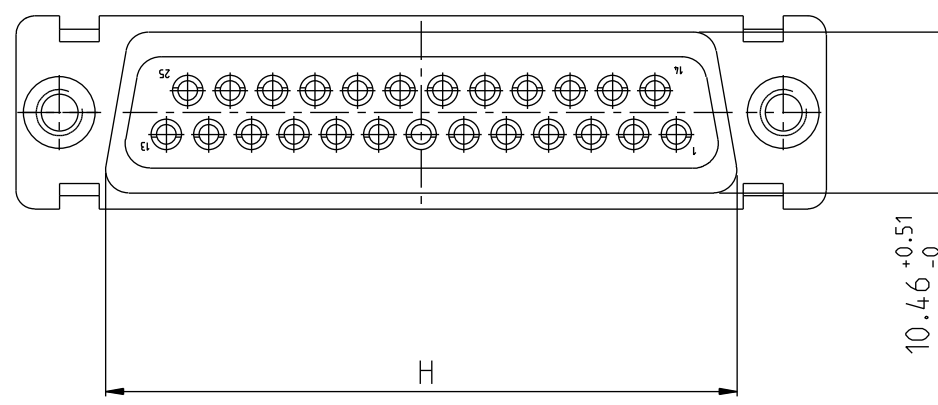

scale 3

Copyright FCI.

www.fciconnect.com		surface ISO 1302	<input checked="" type="checkbox"/>	tolerance std ISO 406	ISO 1101	projection 	mm
		TOLERANCES UNLESS OTHERWISE SPECIFIED					
Dr	M PESSON	2006/11/14	ANGULAR	0.X	± 0.3	size	A2
Eng	P LEGARE	2006/11/14	LINEAR	0.XX	± 0.1	Scale	2:1
Chr	P LEGARE	2006/11/14	0° $\pm 2^\circ$	0.XXX	± 0.05	ECN	LS07-0273
Appr	P LEGARE	2006/11/14	Product family	-		Spec ref	
		title SUB FEMALE DM HE501 series			dwg no	C01-8637-1733	
		with solder bucket				Rev.	D
		catalog no	-		CUSTOMER	sheet 3 of 4	

DIMENSIONS FOR SHELL SIZE D (50 CONTACTS)

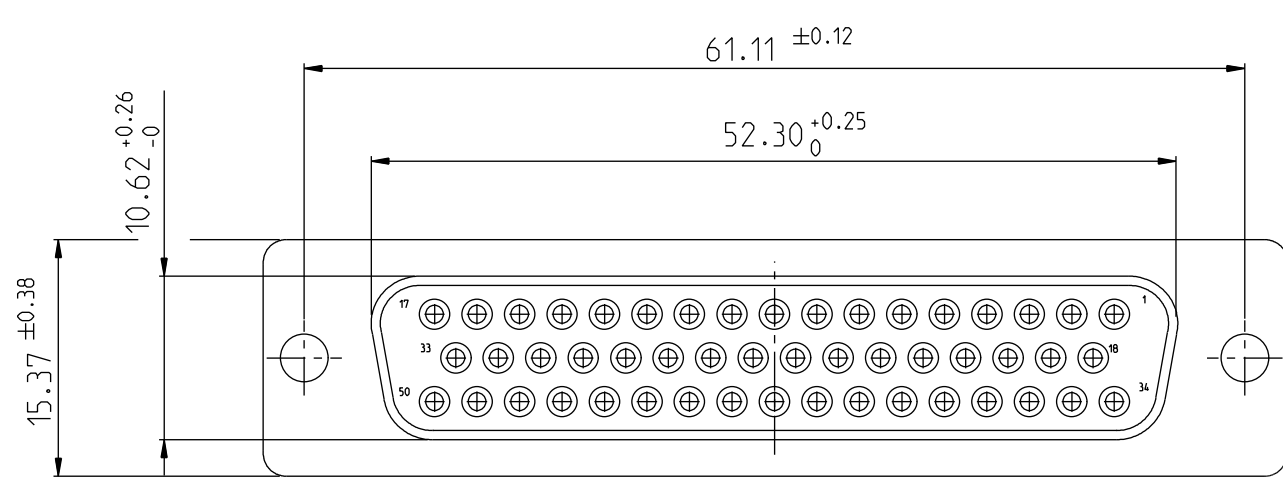
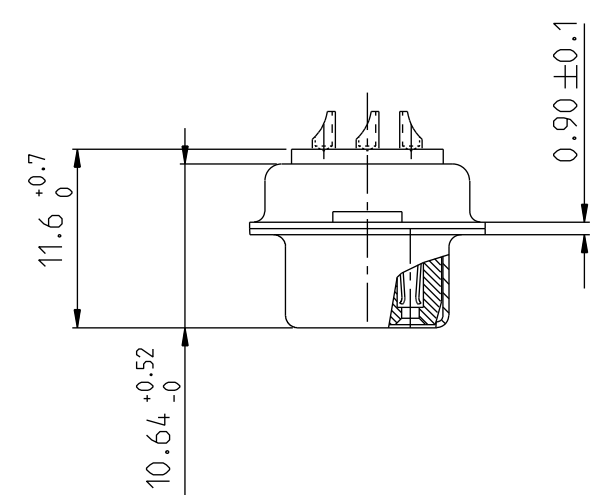
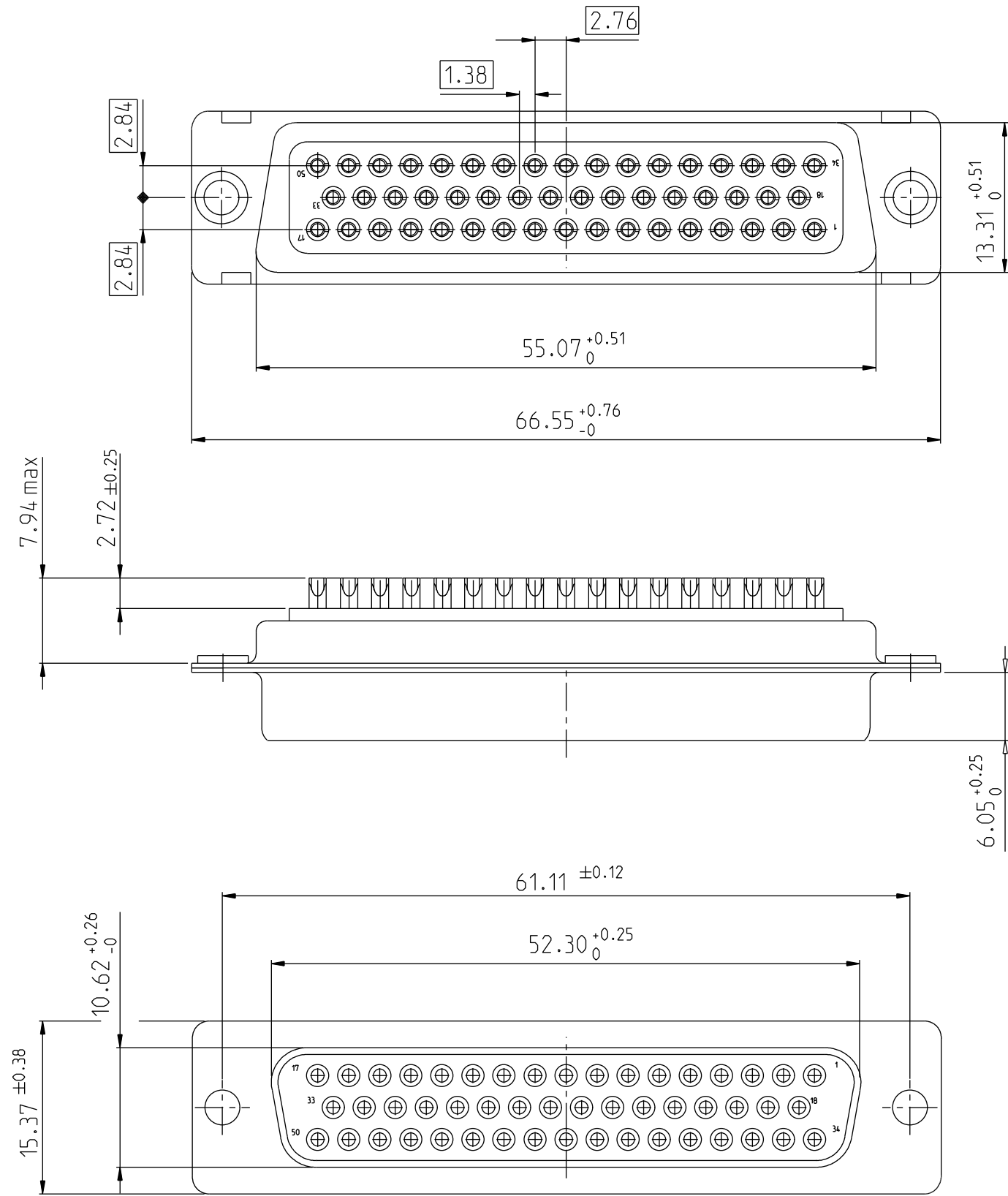

scale 3

www.fciconnect.com		surface ISO 1302	tolerance std ISO 406 ISO 1101	projection mm
		TOLERANCES UNLESS OTHERWISE SPECIFIED		mm
Dr	M PESSON	2006/11/14	ANGULAR	size A2
Eng	P LEGARE	2006/11/14	LINEAR	Scale 2:1
Chr	P LEGARE	2006/11/14	0° ±2°	ECN LS07-0273
Appr	P LEGARE	2006/11/14	Product family	- Spec ref
FCI title SUB FEMALE DM HE501 series		dwg no C01-8637-1733		Rev. D
with solder bucket		CUSTOMER		sheet 4 of 4
catalog no				

Copyright FCI. FCI