

# ON Semiconductor

## Is Now

# onsemi™

To learn more about onsemi™, please visit our website at  
[www.onsemi.com](http://www.onsemi.com)

---

**onsemi** and **onsemi** and other names, marks, and brands are registered and/or common law trademarks of Semiconductor Components Industries, LLC dba "**onsemi**" or its affiliates and/or subsidiaries in the United States and/or other countries. **onsemi** owns the rights to a number of patents, trademarks, copyrights, trade secrets, and other intellectual property. A listing of **onsemi** product/patent coverage may be accessed at [www.onsemi.com/site/pdf/Patent-Marking.pdf](http://www.onsemi.com/site/pdf/Patent-Marking.pdf). **onsemi** reserves the right to make changes at any time to any products or information herein, without notice. The information herein is provided "as-is" and **onsemi** makes no warranty, representation or guarantee regarding the accuracy of the information, product features, availability, functionality, or suitability of its products for any particular purpose, nor does **onsemi** assume any liability arising out of the application or use of any product or circuit, and specifically disclaims any and all liability, including without limitation special, consequential or incidental damages. Buyer is responsible for its products and applications using **onsemi** products, including compliance with all laws, regulations and safety requirements or standards, regardless of any support or applications information provided by **onsemi**. "Typical" parameters which may be provided in **onsemi** data sheets and/or specifications can and do vary in different applications and actual performance may vary over time. All operating parameters, including "Typicals" must be validated for each customer application by customer's technical experts. **onsemi** does not convey any license under any of its intellectual property rights nor the rights of others. **onsemi** products are not designed, intended, or authorized for use as a critical component in life support systems or any FDA Class 3 medical devices or medical devices with a same or similar classification in a foreign jurisdiction or any devices intended for implantation in the human body. Should Buyer purchase or use **onsemi** products for any such unintended or unauthorized application, Buyer shall indemnify and hold **onsemi** and its officers, employees, subsidiaries, affiliates, and distributors harmless against all claims, costs, damages, and expenses, and reasonable attorney fees arising out of, directly or indirectly, any claim of personal injury or death associated with such unintended or unauthorized use, even if such claim alleges that **onsemi** was negligent regarding the design or manufacture of the part. **onsemi** is an Equal Opportunity/Affirmative Action Employer. This literature is subject to all applicable copyright laws and is not for resale in any manner. Other names and brands may be claimed as the property of others.



ON Semiconductor®

# FAN3988

## USB/Charger and Over-Voltage Detection Device

### Features

- Charger/USB Detection Device
- Charger/USB Device Detection Flag
- Over-/Under-Voltage Detection Flag
- V<sub>BUS</sub> Supply: 2.7 V to 20 V
- C<sub>ON</sub> of 1.5 pF
- 6-Lead MicroPak™ MLP Package

### Applications

- Mobile Phones
- Handheld Devices

### Description

The FAN3988 is a USB-connection-monitoring device used to determine if a standard USB device or a battery-charging device is connected.

The FAN3988 sets the FLAG1 pin to logic HIGH or LOW as an indicator to the system controller that a standard USB device or a charger is connected to the USB port. The FAN3988 also monitors the V<sub>BUS</sub> for over- or under-voltage conditions. The FLAG2 pin is set LOW if V<sub>BUS</sub> is less than 3.3 V or greater than 6.0 V.

The FAN3988 is packaged in a very small 6-lead MicroPak™ MLP package suitable for small board space applications, such as mobile phones.

### Ordering Information

Part Number	Operating Temperature Range	Package	Packing Method	Quantity
FAN3988IL6X	-40°C to +85°C	6-Lead MicroPak™ MLP Package	Reel	5000
FAN3988IL6X-F113 <sup>(1)</sup>				

#### Note:

1. Legacy product number; please order FAN3988IL6X for new designs.

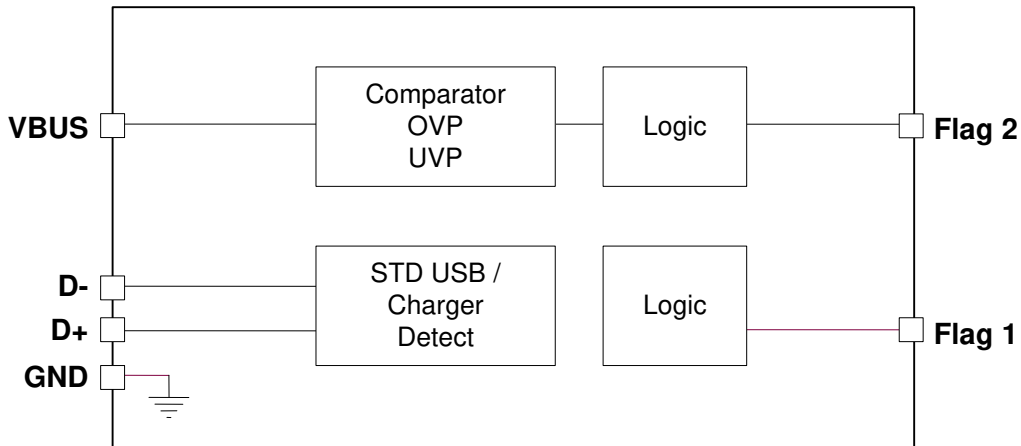

Figure 1. Block Diagram

## Pin Configuration

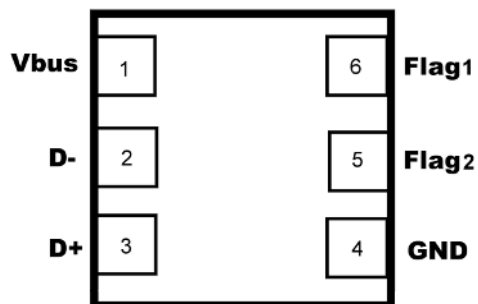

Figure 2. Pin Configuration (Top View)

## Pin Definitions

Pin#	Name	Type	Description
1	Vbus	Input	Power input from charger, USB device, or handheld battery
2	D-	Input	USB data input
3	D+	Input	USB data input
4	Gnd	Input	Device ground
5	Flag2	Output	Over/under-voltage flag output
6	Flag1	Output	Charger/standard USB device detect flag

## Truth Table

Connection State	V <sub>BUS</sub> (V)	D-	D+	FLAG1	FLAG2
STD USB Device <sup>(2)</sup>	0	Open	Open	LOW	LOW
STD USB Device	0	R to GND	R to GND	LOW	LOW
STD USB Device	5	R to GND	R to GND	LOW	HIGH
USB Charger	5	Short to D+	Short to D-	HIGH	HIGH
V <sub>BUS</sub> > 6 V	> 6	Short to D+	Short to D-	HIGH	LOW
V <sub>BUS</sub> < 3.3 V	< 3.3	Short to D+	Short to D-	HIGH	LOW
PC Data/Charger	5	Open	Open	LOW	HIGH

**Note:**

2. See Figure 7.

## Absolute Maximum Ratings

Stresses exceeding the absolute maximum ratings may damage the device. The device may not function or be operable above the recommended operating conditions and stressing the parts to these levels is not recommended. In addition, extended exposure to stresses above the recommended operating conditions may affect device reliability. The absolute maximum ratings are stress ratings only.

Symbol	Parameter	Min.	Max.	Unit
V <sub>BUS</sub>	DC Supply Voltage	-0.3	20.0	V

## Reliability Information

Symbol	Parameter	Min.	Typ.	Max.	Unit
T <sub>J</sub>	Junction Temperature			+150	°C
T <sub>STG</sub>	Storage Temperature Range	-65		+150	°C
θ <sub>JA</sub>	Thermal Resistance, JEDEC Standard, Multi-layer Test Boards, Still Air		41		°C/W

## ESD Information

Symbol	Parameter		Max.	Unit
ESD	Electrostatic Discharge Information	Human Body Model, JESD22-A114	5	kV
		Charged Device Model, JESD22-C101	2	

## Recommended Operating Conditions

The Recommended Operating Conditions table defines the conditions for actual device operation. Recommended operating conditions are specified to ensure optimal performance to the data sheet specifications. ON Semiconductor does not recommend exceeding them or designing to Absolute Maximum Ratings.

Symbol	Parameter	Min.	Typ.	Max.	Unit
T <sub>A</sub>	Operating Temperature Range	-40		+85	°C
V <sub>BUS</sub>	Supply Voltage Range	2.7	5.0	20.0	V

## DC Electrical Characteristics

$T_A = 25^\circ\text{C}$  and  $V_{\text{BUS}} = 5.0\text{ V}$ , unless otherwise noted.

Symbol	Parameter	Condition	Min.	Typ.	Max.	Unit
<b>Supply</b>						
$V_{\text{BUS}}$	Supply Voltage Range	$V_{\text{BUS}}$ Range	2.7	5.0	20.0	V
$I_{\text{BUS}}$	Quiescent Supply Current	$V_{\text{BUS}} = +5.0\text{ V}$ , D+ D- Shorted		1.2	2.0	mA
$t_{\text{SUPPLY}}$	Power-Up Stabilization Time	$V_{\text{BUS}} = +5.0\text{ V}$ , D+ D- Shorted		10		ms
<b>Input Characteristics</b>						
$C_{\text{D+}}$	Input Capacitance			1.5	2.0	pF
$C_{\text{D-}}$	Input Capacitance			1.5	2.0	pF
$I_{\text{off D+}}$	Off Leakage Current	$V_{\text{BUS}} = 0\text{ V}$ or $5\text{ V}$ $V_{\text{IN}}$ on D+ = $5\text{ V}$		1		$\mu\text{A}$
$I_{\text{off D-}}$	Off Leakage Current	$V_{\text{BUS}} = 0\text{ V}$ or $5\text{ V}$ $V_{\text{IN}}$ on D- = $5\text{ V}$		1		$\mu\text{A}$
<b>Output Characteristics</b>						
$OV_{\text{DETECT}}$	Over-Voltage Threshold Detect	$V_{\text{BUS}} = +5.0\text{ V}$ , Flag2 = LOW	5.8	6.0	6.5	V
$OV_{\text{HYST}}$	Over-Voltage Hysteresis	Voltage Sweep through Upper and Lower Trip Points		100		mV
$UV_{\text{DETECT}}$	Under-Voltage Threshold Detect	$V_{\text{BUS}} = +5.0\text{ V}$ , Flag2 = LOW	3.0	3.3	3.6	V
$UV_{\text{HYST}}$	Under-Voltage Hysteresis	Voltage Sweep through Upper and Lower Trip Points		100		mV
$V_{\text{OH FLAG1/FLAG2}}$	Minimum HIGH Output Voltage	$V_{\text{BUS}} = +5.0\text{ V}$ , $I_{\text{OH}} = -20\ \mu\text{A}$	2.4		2.6	V
$V_{\text{OL FLAG1/FLAG2}}$	Maximum LOW Output Voltage	$V_{\text{BUS}} = +5.0\text{ V}$ , $I_{\text{OL}} = 20\ \mu\text{A}$			0.3	V
$I_{\text{OH FLAG1/FLAG2}}$	Minimum HIGH Output Current		-20			$\mu\text{A}$
$I_{\text{OL FLAG1/FLAG2}}$	Maximum HIGH Output Current				20	$\mu\text{A}$
$D_+/D_-$ Threshold	USB SDP (Standard Downstream Port)	D+ = 3V; D- = 0V-3V or 3V-0V D- = 3V; D+ = 0V-3V or 3V-0V	1.025	1.300	1.365	V
	USB DCP (Dedicated Charging Port)	D+/D- = 0V-3V, 3V-0V		1.450		V
$t_{\text{off}}$	Flag2 HIGH to LOW	100 pF Load		10		ns
$t_{\text{on}}$	Flag2 LOW to HIGH	100 pF Load		44		ns

## Typical Performance Characteristics

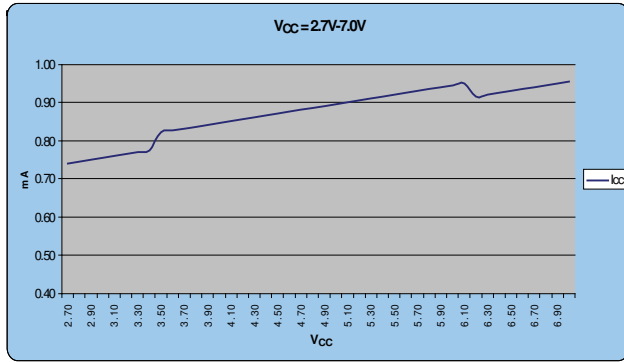

Figure 3. I<sub>Bus</sub> vs. V<sub>Bus</sub> (2.7 V-7.0 V) No Load

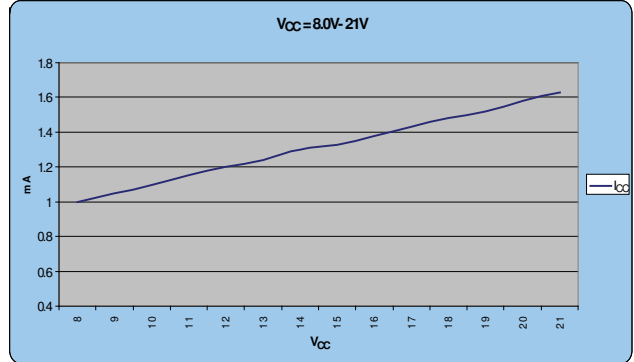

Figure 4. I<sub>Bus</sub> vs. V<sub>Bus</sub> (8.0V-21 V) No Load

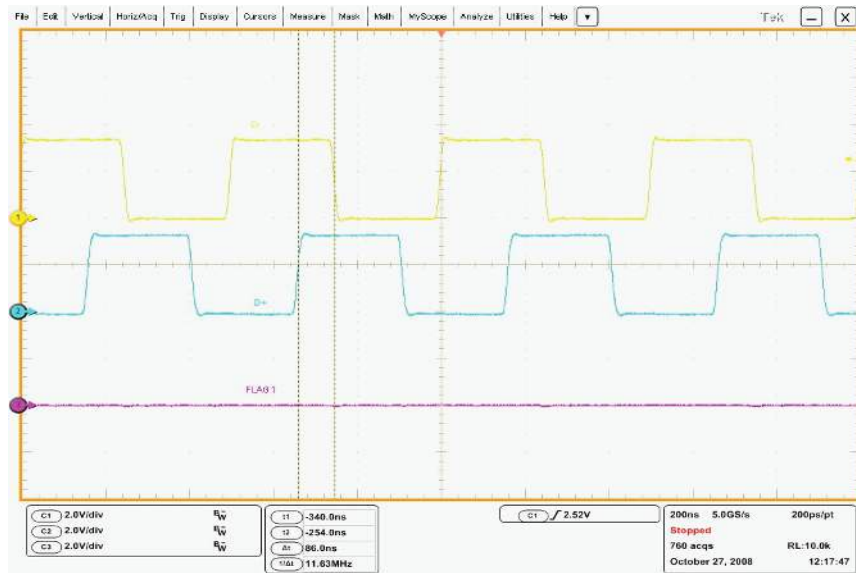

Figure 5. No Fault on Flag 1, Skew=65 ns

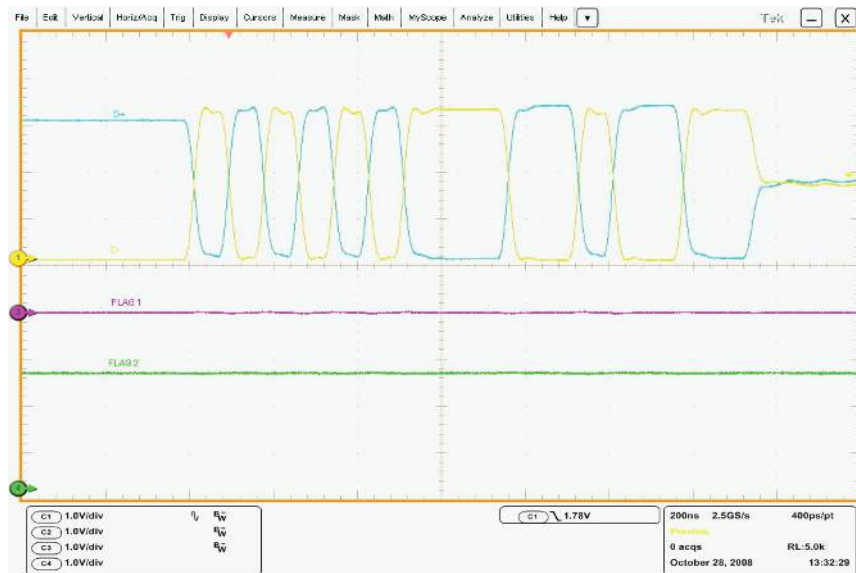

Figure 6. PC Data Running D+/D- (Flag 1 and Flag 2 at Correct Levels)

## Application Information

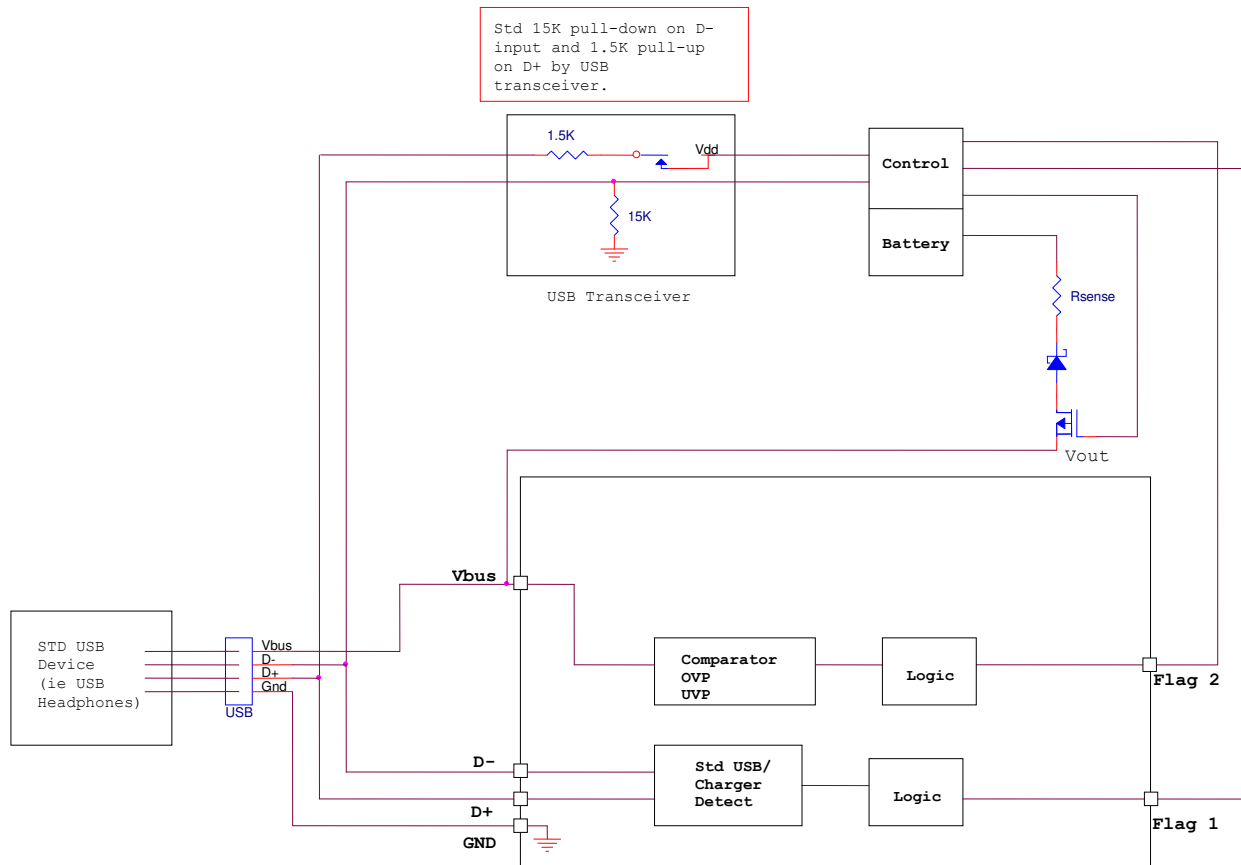

Figure 7. Typical Application System with USB Transceiver

### With USB Transceiver (Figure 7)

The FAN3988 sets the FLAG1 pin to logic HIGH or LOW as an indicator to the system controller that a standard USB device or a charger is connected to the USB port. The FAN3988 also monitors the  $V_{BUS}$  for over- or under-voltage conditions. The FLAG2 pin is set LOW if  $V_{BUS}$  is less than 3.3 V or greater than 6.0 V.

In a standard USB configuration, there is a switch in the USB transceiver that is always ON in the full-speed mode. It is ON during the transition from full-speed mode to high-speed mode and is turned off after enumeration is complete.

In a condition where D+ and D- are shorted when a charger is plugged into the USB port, the USB switch is ON and pulled to  $V_{DD}$ , which is about 3.3 V, making both D+ and D- HIGH and flag1 set HIGH – indicating that a charging device is connected to the port.

In a condition where D+ and D- are connected to a standard USB device, the D+ is pulled to  $V_{DD}$  and D- is set LOW (due to the 15 k $\Omega$  pull-down in the USB transceiver) and flag1 is LOW.

If D+ and D- are open (floating), D+ is pulled to  $V_{DD}$  and D- floats LOW, which makes flag1 LOW.

### Without USB Transceiver (Figure 8)

The FAN3988 sets the FLAG1 pin to logic HIGH or LOW as an indicator to the system controller that a standard USB device or a charger is connected to the USB port. The FAN3988 also monitors the  $V_{BUS}$  for over- or under-voltage conditions. The FLAG2 pin is set LOW if  $V_{BUS}$  is less than 3.3 V or greater than 6.0 V.

In a condition where a USB transceiver is not incorporated or there is a switch between the USB port and the FAN3988, external resistors must be used to set the correct input logic states on the D+ D- inputs. A 5 M $\Omega$  pull-down on the D- line and a 1 M $\Omega$  pull-up on the D+ line are recommended.

When a condition exists where a charger is plugged into the USB port (D+ D- shorted), the voltage divider of 1 M $\Omega$  and 5 M $\Omega$  puts a voltage of 2.75 V on the D+ D- inputs and flag1 is HIGH, indicating a charger is connected to port.

In a condition where the USB port is connected to a standard USB device, the D+ input is pulled up to  $V_{DD}$  (system supply) in parallel with the 1.5 k $\Omega$  on a USB transceiver with a parallel R value of 1.497 k $\Omega$ . The D- input is connected to a 15 k $\Omega$  pull-down by the USB device and in parallel with 5 M $\Omega$  with a parallel R value of 14.955 k $\Omega$ . This condition makes flag1 LOW.

If D+ and D- are open (floating), D+ is pulled to  $V_{DD}$  (system supply) and D- floats LOW, which makes flag1 LOW.

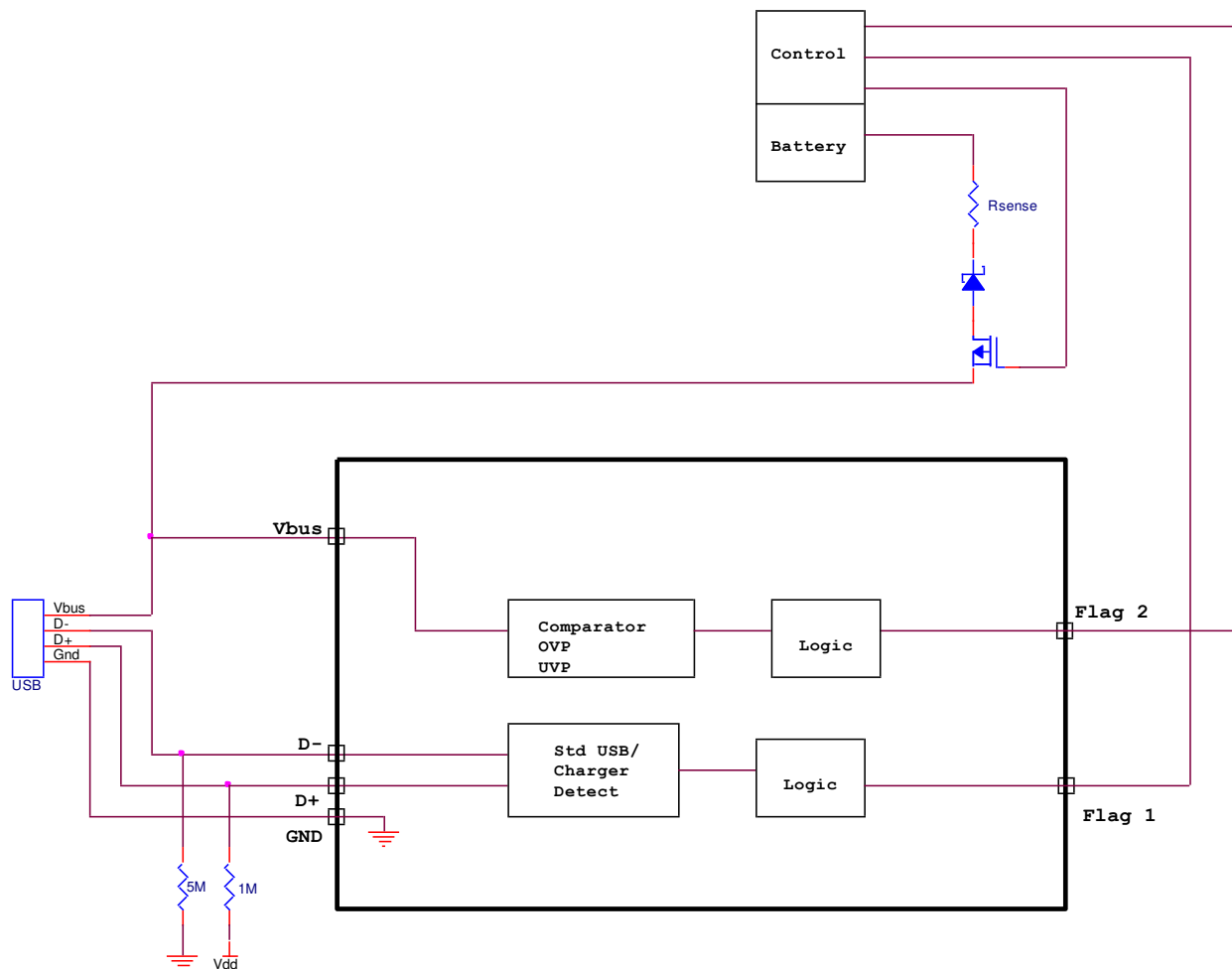

Figure 8. Typical System Application without USB Transceiver



ON Semiconductor and  are trademarks of Semiconductor Components Industries, LLC dba ON Semiconductor or its subsidiaries in the United States and/or other countries. ON Semiconductor owns the rights to a number of patents, trademarks, copyrights, trade secrets, and other intellectual property. A listing of ON Semiconductor's product/patent coverage may be accessed at [www.onsemi.com/site/pdf/Patent-Marking.pdf](http://www.onsemi.com/site/pdf/Patent-Marking.pdf). ON Semiconductor reserves the right to make changes without further notice to any products herein. ON Semiconductor makes no warranty, representation or guarantee regarding the suitability of its products for any particular purpose, nor does ON Semiconductor assume any liability arising out of the application or use of any product or circuit, and specifically disclaims any and all liability, including without limitation special, consequential or incidental damages. Buyer is responsible for its products and applications using ON Semiconductor products, including compliance with all laws, regulations and safety requirements or standards, regardless of any support or applications information provided by ON Semiconductor. "Typical" parameters which may be provided in ON Semiconductor data sheets and/or specifications can and do vary in different applications and actual performance may vary over time. All operating parameters, including "Typicals" must be validated for each customer application by customer's technical experts. ON Semiconductor does not convey any license under its patent rights nor the rights of others. ON Semiconductor products are not designed, intended, or authorized for use as a critical component in life support systems or any FDA Class 3 medical devices or medical devices with a same or similar classification in a foreign jurisdiction or any devices intended for implantation in the human body. Should Buyer purchase or use ON Semiconductor products for any such unintended or unauthorized application, Buyer shall indemnify and hold ON Semiconductor and its officers, employees, subsidiaries, affiliates, and distributors harmless against all claims, costs, damages, and expenses, and reasonable attorney fees arising out of, directly or indirectly, any claim of personal injury or death associated with such unintended or unauthorized use, even if such claim alleges that ON Semiconductor was negligent regarding the design or manufacture of the part. ON Semiconductor is an Equal Opportunity/Affirmative Action Employer. This literature is subject to all applicable copyright laws and is not for resale in any manner.

## PUBLICATION ORDERING INFORMATION

### LITERATURE FULFILLMENT:

Literature Distribution Center for ON Semiconductor  
19521 E. 32nd Pkwy, Aurora, Colorado 80011 USA  
**Phone:** 303-675-2175 or 800-344-3860 Toll Free USA/Canada  
**Fax:** 303-675-2176 or 800-344-3867 Toll Free USA/Canada  
**Email:** [orderlit@onsemi.com](mailto:orderlit@onsemi.com)

**N. American Technical Support:** 800-282-9855 Toll Free  
USA/Canada  
**Europe, Middle East and Africa Technical Support:**  
Phone: 421 33 790 2910  
**Japan Customer Focus Center**  
Phone: 81-3-5817-1050

**ON Semiconductor Website:** [www.onsemi.com](http://www.onsemi.com)  
**Order Literature:** <http://www.onsemi.com/orderlit>  
For additional information, please contact your local  
Sales Representative