

Silicon Standard Recovery Diode

$V_{RRM} = 200\text{ V} - 800\text{ V}$

$I_F = 100\text{ A}$

Features

- High Surge Capability
- Types from 200 V to 800 V V_{RRM}
- Not ESD Sensitive

Note:

1. Standard polarity: Stud is cathode.
2. Reverse polarity (R): Stud is anode.
3. Stud is base.

DO-8 Package

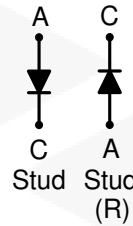

Maximum ratings, at $T_j = 25\text{ }^\circ\text{C}$, unless otherwise specified ("R" devices have leads reversed)

Parameter	Symbol	Conditions	1N3289A(R)	1N3291A(R)	1N3293A(R)	1N3294A(R)	Unit
Repetitive peak reverse voltage	V_{RRM}		200	400	600	800	V
DC blocking voltage	V_{DC}		200	400	600	800	V
Continuous forward current	I_F	$T_C \leq 130\text{ }^\circ\text{C}$	100	100	100	100	A
Surge non-repetitive forward current, Half Sine Wave	$I_{F,SM}$	$T_C = 25\text{ }^\circ\text{C}$, $t_p = 8.3\text{ ms}$	2300	2300	2300	2300	A
I_2t for fusing	I_2t	60 Hz Half wave	22000	22000	22000	22000	A^2sec
Operating temperature	T_j		-55 to 150	-55 to 150	-55 to 150	-55 to 150	$^\circ\text{C}$
Storage temperature	T_{stg}		-55 to 150	-55 to 150	-55 to 150	-55 to 150	$^\circ\text{C}$

Electrical characteristics, at $T_j = 25\text{ }^\circ\text{C}$, unless otherwise specified

Parameter	Symbol	Conditions	1N3289A(R)	1N3291A(R)	1N3293A(R)	1N3294A(R)	Unit
Diode forward voltage	V_F	$I_F = 100\text{ A}$, $T_j = 130\text{ }^\circ\text{C}$	1.5	1.5	1.5	1.5	V
Reverse current	I_R	$V_R = V_{RRM}$, $T_j = 130\text{ }^\circ\text{C}$	24	24	17	13	mA

Thermal characteristics

Parameter	Symbol	Conditions	1N3289A(R)	1N3291A(R)	1N3293A(R)	1N3294A(R)	Unit
Thermal resistance, junction - case	R_{thJC}		0.40	0.40	0.40	0.40	$^\circ\text{C/W}$

Electrical Characteristics

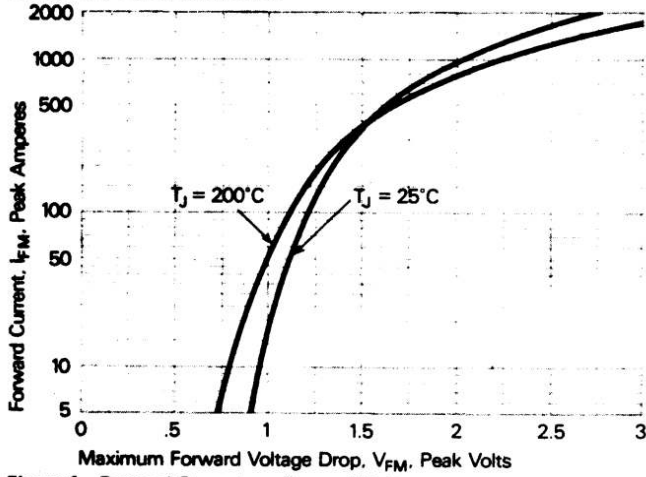

Figure 1. Forward Current vs. Forward Voltage.

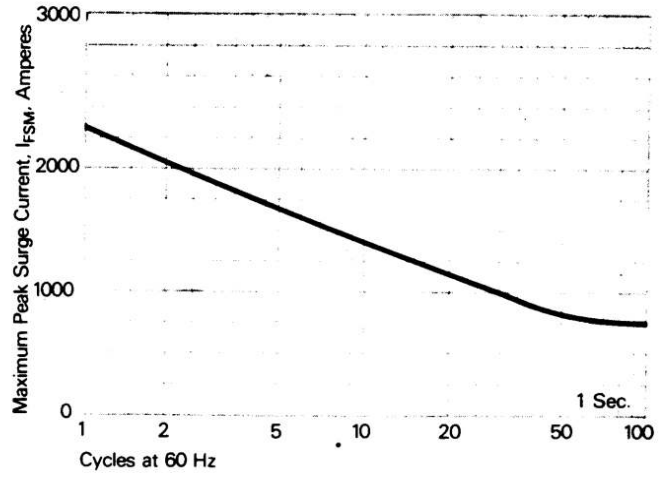

Figure 2. Maximum allowable surge current at rated load conditions.

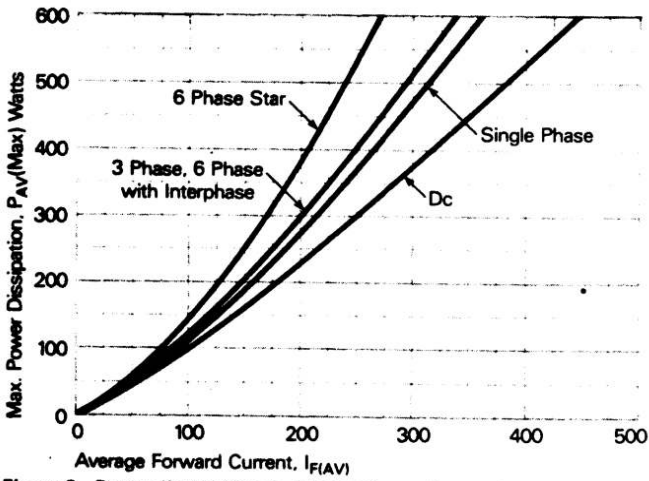

Figure 3. Power dissipation vs. Average forward current.

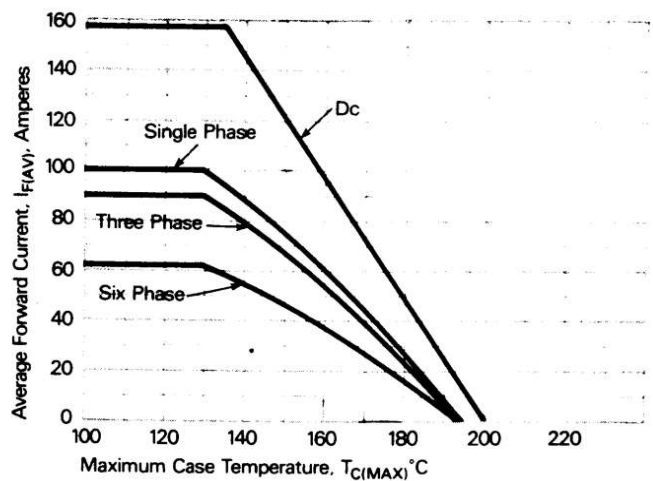
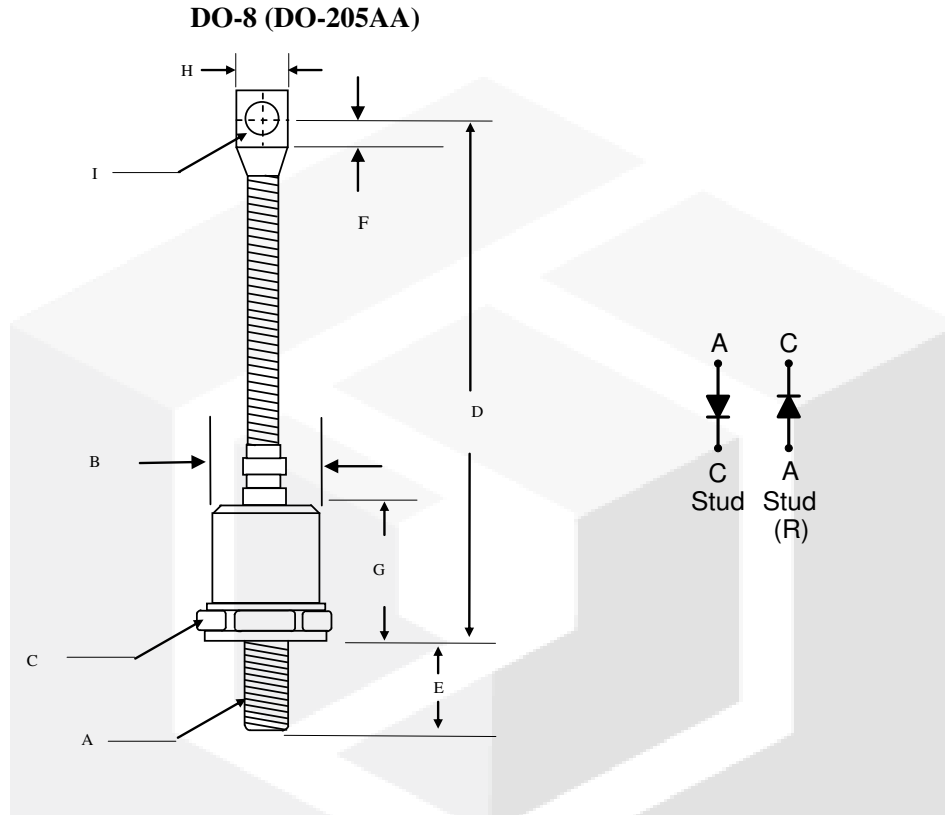

Figure 4. Forward Current vs. Case Temperature.



Package dimensions and terminal configuration

Product is marked with part number and terminal configuration.



	Inches		Millimeters	
	Min	Max	Min	Max
A	3/8-24 UNF			
B	----	φ0.930	----	φ23.5
C	1.050	1.060	26.67	26.92
D	4.300	4.700	109.22	119.38
E	----	0.690	----	17.00
F	0.260	----	6.50	----
G	----	0.940	----	24.00
H	----	0.600	----	15.23
I	0.276	0.286	7.010	7.260