

GPy 1.0

With WiFi, BLE and cellular LTE-CAT M1/NB1, the GPy is the latest Pycom triple-bearer MicroPython enabled micro controller on the market today – the perfect enterprise grade IoT platform for your connected Things. Create and connect your things everywhere, fast.

GPy Features

- Powerful CPU
- 1KM Wifi Range
- MicroPython enabled
- Fits in a standard breadboard (with headers)
- Ultra-low power usage: a fraction compared to other connected micro controllers

LTE-M Operating Frequencies

- 34 bands supported from 699Mhz to 2690Mhz (Total world-wide support)

LTE-M Specification

- One single chip for both CAT M1 and NB1 (yes, only one chip)
- 3GPP release 13 LTE Advanced Pro
- Supports narrowband LTE UE categories M1/NB1
- Integrated baseband, RF, RAM memory and power management
- Reduced Tx power class option
- Peak power estimations: TX current = 420mA peak @1.5Watt
RX current = 330mA peak @1.2Watt
- Data rates:
 - 300 kbps DL
 - 375 kbps UL (LTE Cat M1 in 1.4 Mhz, HD-FDD)
 - 40 kbps DL
 - 55 kbps UL (LTE Cat M2 in 200 kHz, HD-FDD)

Interfaces

- 2 x UART, 2 x SPI, I2C, I2S, micro SD card
- Analog channels: 8x12 bit ADCs, 2x8 bit DAC
- Timers: 2x64 bit with PWM with up to 16 channels
- DMA on all peripherals

Power

- Voltage Input: 3.3V - 5.5V
- 3v3 output capable of sourcing up to 400mA

Mechanical

Size: 55mm x 20mm x 3.5mm

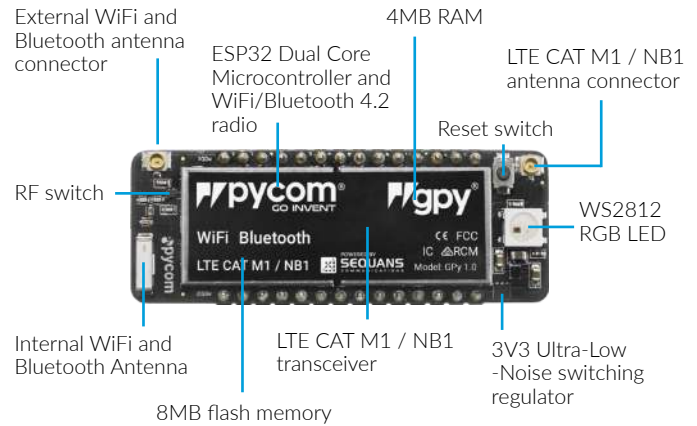

Processing

- Espressif ESP32 SoC
- Dual processor + WiFi radio System on Chip.
- Network processor handles the WiFi connectivity and the IPv6 stack
- Main processor is entirely free to run the user application
- An extra ULP-coprocessor that can monitor GPIOs, the ADC channels and control most of the internal peripherals during deep-sleep mode while only consuming 25uA

Security & Certifications

- SSL/TLS support up to 1.2
- WPA Enterprise security
- AES encryption engine

Hash / encryption

SHA, MD5, DES, AES

WiFi Networking

802.11b/g/n 16mbps

Bluetooth

Low energy and classic

RTC

Running at 32KHz

Memory

- RAM: 4MB
- Flash Memory: 8MB
- GPIO: Up to 22
- Hardware floating point acceleration
- Python multi-threading

Use the Pymakr IDE

Super easy code editor to write your Python scripts

Easy Upload

Upload your scripts, and any other files you want to the GPy via the FTP server

Locally or remotely

Reset the GPy (you can do it locally, or remotely via Telnet)

EU Regulatory Conformance

Hereby, Pycom Ltd declares that this device is in compliance with the essential requirements and other relevant provisions of Directive 1999/5/EC

Federal Communication Commission Interference Statement

This device complies with Part 15 of the FCC Rules. Operation is subject to the following two conditions:

- (1) This device may not cause harmful interference.
- (2) This device must accept any interference received, including interference that may cause undesired operation.

CAUTION: Changes or modifications not expressly approved by the party responsible for compliance could void the user's authority to operate the equipment.

NOTE: This equipment has been tested and found to comply with the limits for a Class B digital device, pursuant to Part 15 of the FCC Rules. These limits are designed to provide reasonable protection against harmful interference in a residential installation. This equipment generates uses and can radiate radio frequency energy and, if not installed and used in accordance with the instructions, may cause harmful interference to radio communications. However, there is no guarantee that interference will not occur in a particular installation. If this equipment does cause harmful interference to radio or television reception, which can be determined by turning the equipment off and on, the user is encouraged to try to correct the interference by one or more of the following measures:

- Reorient or relocate the receiving antenna.
- Increase the separation between the equipment and receiver.
- Connect the equipment into an outlet on a circuit different from that to which the receiver is connected.
- Consult the dealer or an experienced radio/TV technician for help.

RF Warning Statement

To comply with FCC RF exposure compliance requirements, the antennas used for this transmitter must be installed to provide a separation distance of at least 20 cm from all persons and must not be co-located or operating in conjunction with any other antenna or transmitter.

This device is intended only for OEM integrators under the following conditions:

- 1) The antenna must be installed such that 20 cm is maintained between the antenna and users, and
- 2) The transmitter module may not be co-located with any other transmitter or antenna.

As long as two conditions above are met, further transmitter test will not be required. However, the OEM integrator is still responsible for testing their end-product for any additional compliance requirements required with this module installed. To ensure compliance with all non-transmitter functions the host manufacturer is responsible for ensuring compliance with the

module(s) installed and fully operational. For example, if a host was previously authorized as an unintentional radiator under the Declaration of Conformity procedure without a transmitter certified module and a module is added, the host manufacturer is responsible for ensuring that after the module is installed and operational the host continues to be compliant with the Part 15B unintentional radiator requirements.

The module is limited to OEM installation ONLY.

The module is limited to installation in mobile or fixed application. We hereby acknowledge our responsibility to provide guidance to the host manufacturer in the event that they require assistance for ensuring compliance with the Part 15 Subpart B requirements.

IMPORTANT NOTE: In the event that these conditions cannot be met (for example certain laptop configurations or co-location with another transmitter), then the FCC authorization is no longer considered valid and the FCC ID cannot be used on the final product. In these circumstances, the OEM integrator will be responsible for reevaluating the end product (including the transmitter) and obtaining a separate FCC authorization.

End Product Labeling

This transmitter module is authorized only for use in device where the antenna may be installed such that 20 cm may be maintained between the antenna and users. The final end product must be labeled in a visible area with the following: "Contains FCC ID: 2AJMTGPY2R". The grantee's FCC ID can be used only when all FCC compliance requirements are met.

The following FCC part 15.19 statement has to also be available on the label:

This device complies with Part 15 of FCC rules. Operation is subject to the following two conditions:

- (1) this device may not cause harmful interference and
- (2) this device must accept any interference received, including interference that may cause undesired operation.

Manual Information to the End User

The OEM integrator has to be aware not to provide information to the end user regarding how to install or remove this RF module in the user's manual of the end product which integrates this module.

In the user manual of the end product, the end user has to be informed that the equipment complies with FCC radio-frequency exposure guidelines set forth for an uncontrolled environment.

The end user has to also be informed that any changes or modifications not expressly approved by the manufacturer could void the user's authority to operate this equipment.

The end user manual shall include all required regulatory information/warning as show in this manual.

The maximum operating ambient temperature of the equipment declared by the manufacturer is
-20~+85C

Receiver category 3