

CKT. SIZE	MATERIAL NUMBER	DIM. "A"	DIM. "B"	DIM. "C"	DIM. "D"	DIM. "E"	DIM. "F"	DIM. "G"	DIM. "H"	DIM. "J"	DIM. "K"	DIM. "L"	DIM. "M"	MATERIAL	PACKAGING SPECIFICATION
4	44516-0002	25.9 (1.02)	9.60 (.378)	4.20 (.165)	N/A	4.50 (.177)	N/A	N/A	4.50 (.177)	N/A	4.80 (.189)	18.00 (.709)	7.60 (.299)	UNFILLED NYLON 6/6 UL94V-0	PK-44516-002
6	44516-0003	30.10 (1.185)	13.80 (.543)	8.40 (.331)	N/A	4.50 (.177)	N/A	N/A	4.50 (.177)	N/A	6.90 (.272)	22.20 (.874)	11.80 (.465)	UNFILLED NYLON 6/6 UL94V-0	PK-44516-002
8	X 44516-0004	34.3 (1.35)	18.00 (.709)	12.60 (.496)	N/A	6.11 (.240)	N/A	4.50 (.177)	N/A	4.50 (.177)	9.00 (.354)	26.40 (1.039)	16.00 (.630)	UNFILLED NYLON 6/6 UL94V-0	PK-44516-002
10	X 44516-0005	38.5 (1.52)	22.20 (.874)	16.80 (.661)	N/A	6.11 (.240)	N/A	4.50 (.177)	N/A	4.50 (.177)	11.10 (.437)	30.60 (1.205)	20.20 (.795)	UNFILLED NYLON 6/6 UL94V-0	PK-44516-002
14	44516-0007	46.9 (1.85)	30.60 (1.205)	25.20 (.992)	6.11 (.240)	3.59 (.141)	6.11 (.240)	4.50 (.177)	3.59 (.141)	4.50 (.177)	15.30 (.602)	39.00 (1.535)	28.60 (1.126)	UNFILLED NYLON 6/6 UL94V-0	PK-44516-005
16	X 44516-0008	51.1 (2.01)	34.80 (1.370)	29.40 (1.157)	6.11 (.240)	4.50 (.177)	6.11 (.240)	4.50 (.177)	4.50 (.177)	4.50 (.177)	17.40 (.685)	43.20 (1.701)	32.80 (1.291)	UNFILLED NYLON 6/6 UL94V-0	PK-44516-002

"X" = NOT TOOLED

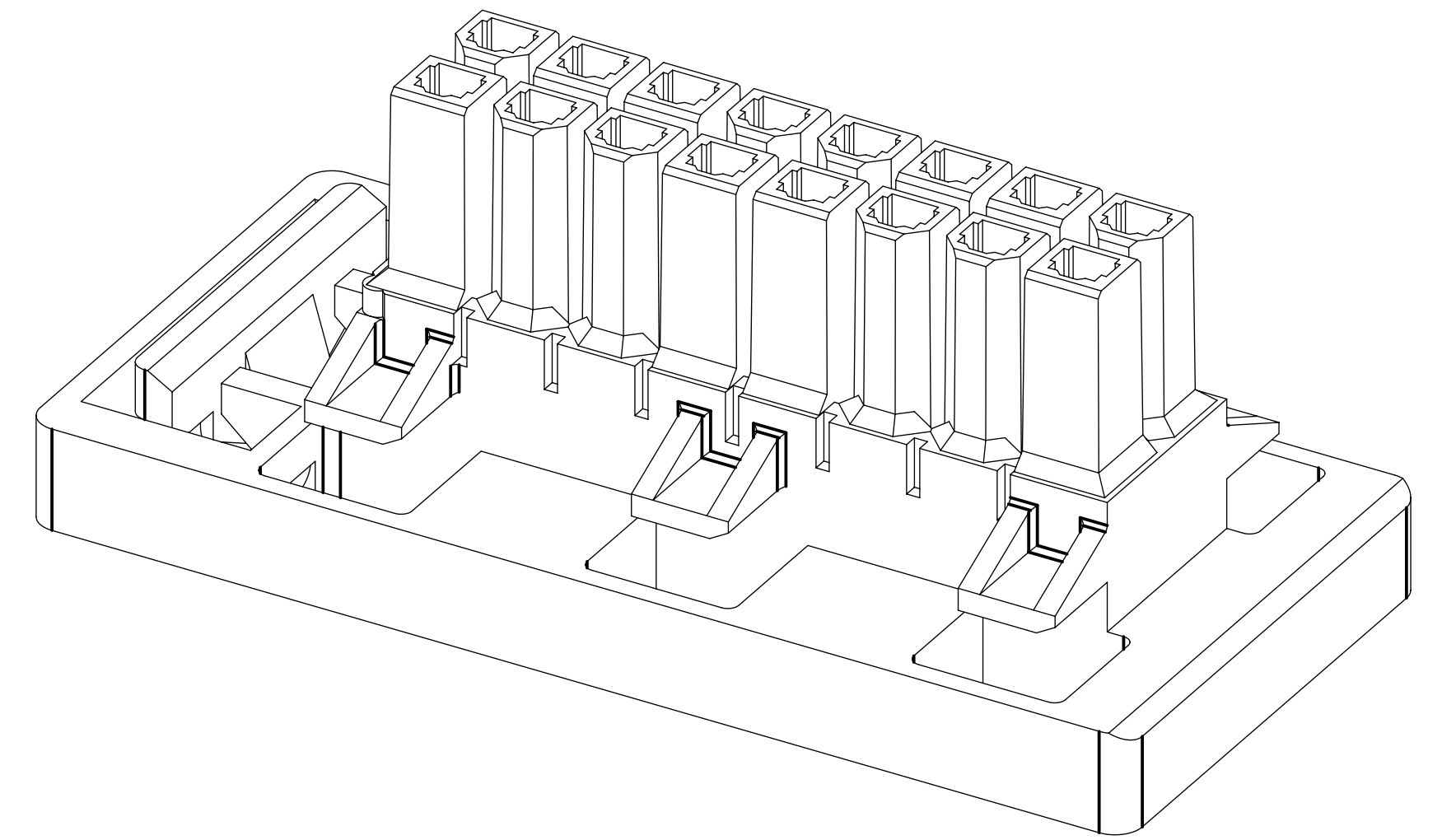
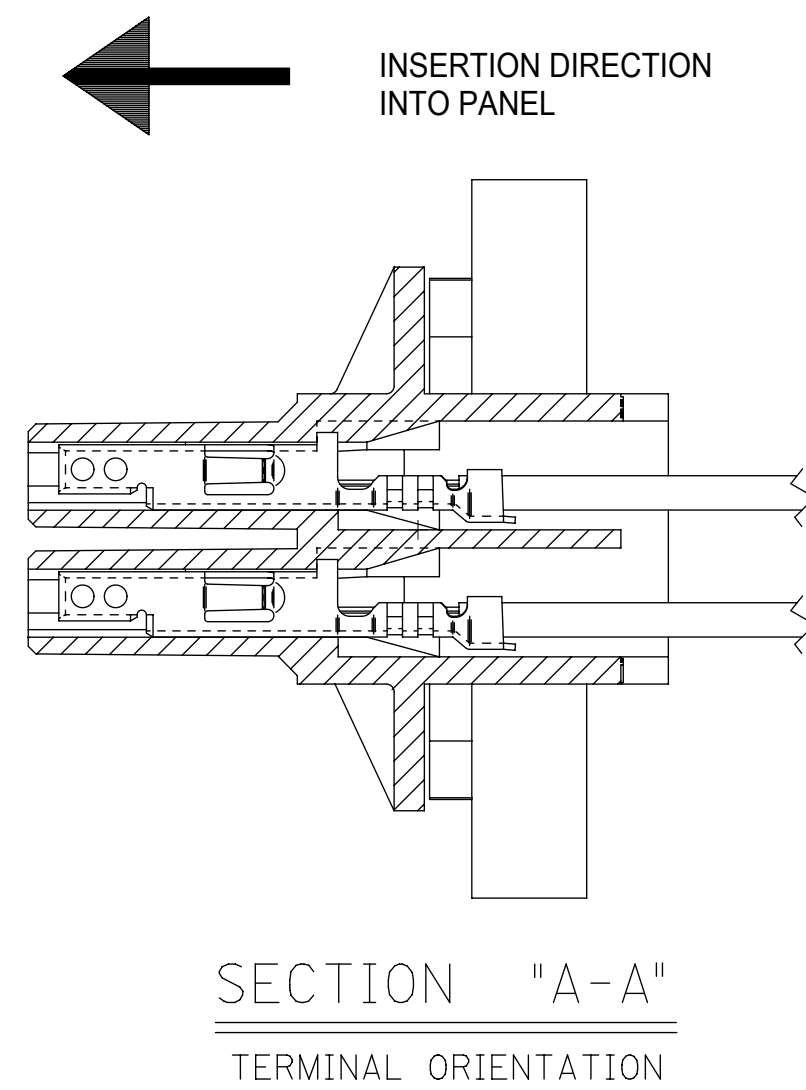
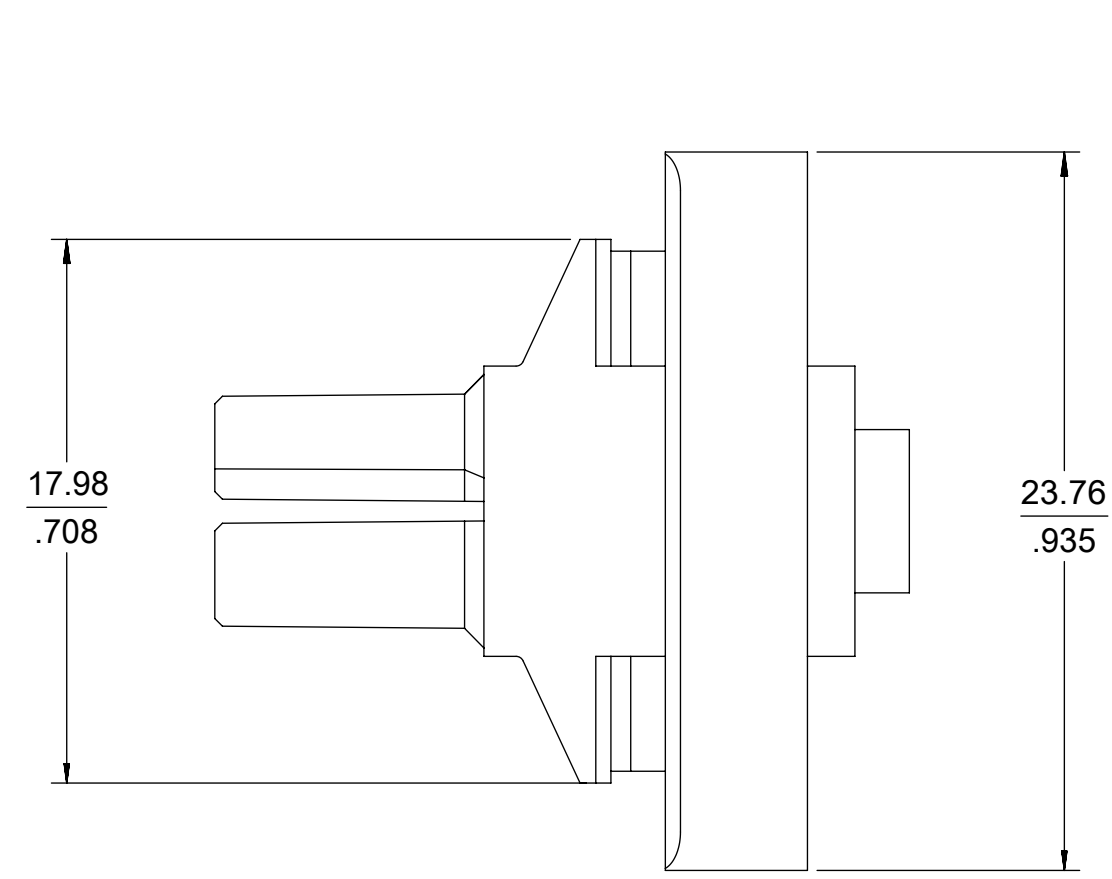
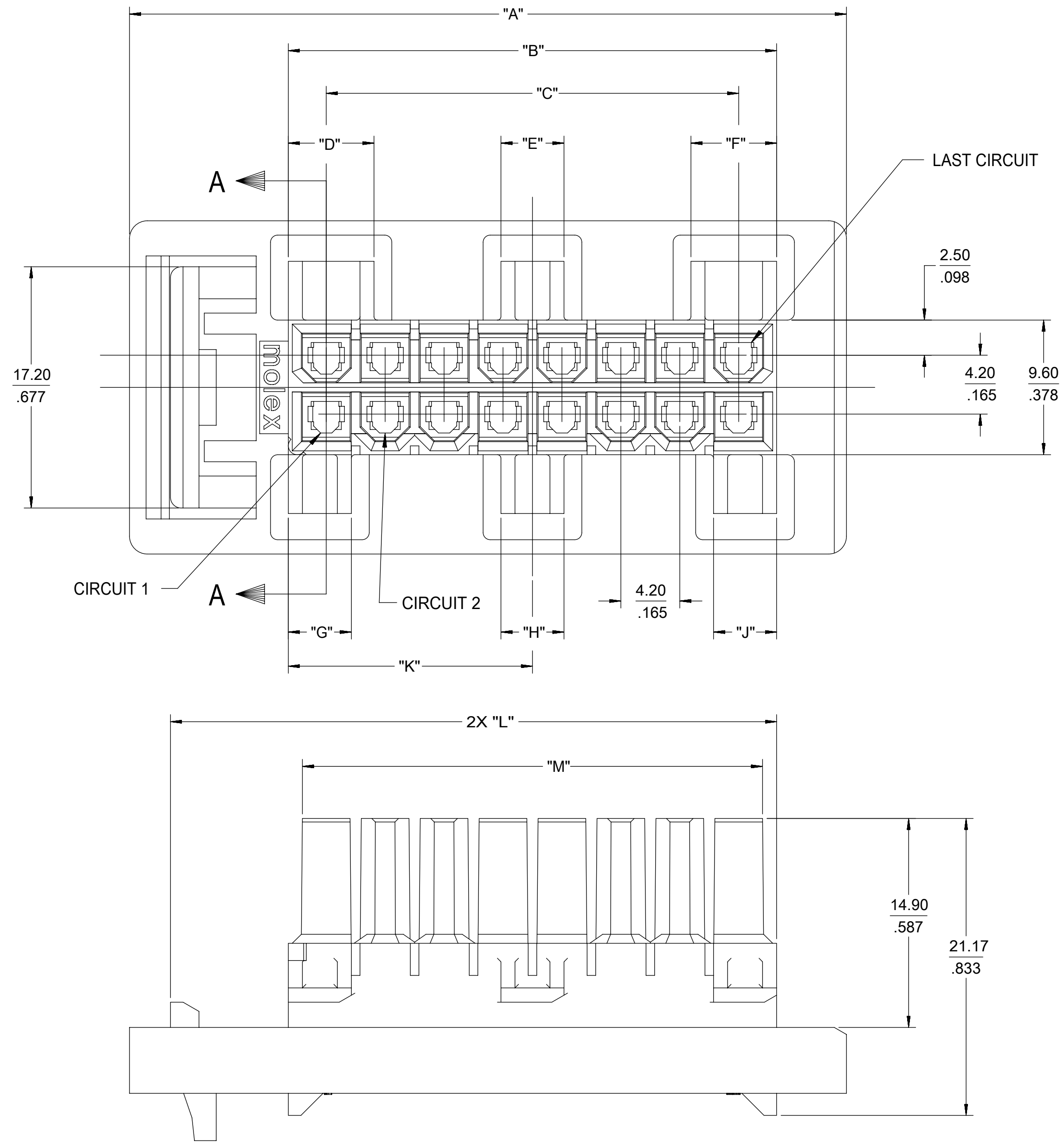

NOTES:

- MATERIAL: SEE CHART, COLOR: BLACK
- FINISH: N/A
- PRODUCT SPECIFICATION: PS-5556-002
- PACKAGING SPECIFICATION: SEE CHART

5. PART MATES WITH MINI-FIT B.M.I. PLUG #42475, AND HEADERS 42404, 42440, 44068, 43879, 43810.

6. A MAXIMUM TOLERANCE OF 1.27/(.050) ALLOWS FOR 2 POINTS OF ELECTRICAL CONTACT. A MAXIMUM TOLERANCE OF .51/(.020) ALLOWS FOR 4 POINTS OF CONTACT.

7. PART TO BE USED WITH MOLEX FEMALE TERMINAL #5556 OR 45750.

8. WIRES TO BE DRESSED IN SUCH A MANNER TO ALLOW THE TERMINALS TO FLOAT FREELY IN THE POCKETS AND THE CONNECTOR TO FLOAT FREELY IN THE PANEL.

9. CONNECTOR ASSEMBLIES ARE NOT TO BE MATED OR UNMATED WHILE CIRCUITS ARE LIVE.

10. PANEL SHOULD BE PUNCHED IN THE DIRECTION OPPOSITE OF CONNECTOR INSERTION.

11. THIS PART IS NOT INTENDED TO PROVIDE ANY ALIGNMENT OF CUSTOMER COMPONENTS OR MODULES, SUCH AS POWER SUPPLIES AND CHASSIS.

12. SEE SHEET 2 FOR PANEL CUTOUT DIMENSIONS. PANEL CUTOUT DIMENSIONS HAVE A TOLERANCE OF .076/(.003).

13. MOLEX RECOMMENDS 1.57/1.19/(.062/.047) MAX./MIN. PANEL THICKNESS.

14. IT IS THE RESPONSIBILITY OF THE CUSTOMER TO ENSURE THAT THE PANEL TO WHICH THE RECEPTACLE IS MOUNTED IS SUFFICIENTLY SUPPORTED SO THAT FLEXING OF THE PANEL DURING MATING DOES NOT PREVENT THE CONNECTOR SYSTEM FROM BEING FULLY MATED.

15. THIS PART IS NOT INTENDED TO ACT AS A HARD STOP FOR CUSTOMER COMPONENTS.

16. THIS CONNECTOR ALLOWS FOR 1.27/(.050) MAX. MISALIGNMENT IN ANY DIRECTION.

17. PART CONFORMS TO CLASS "B" REQUIREMENTS OF COSMETIC SPECIFICATION PS-45499-002 WITH THE EXCEPTION OF SINK & FLASH MEETS CLASS "C" REQUIREMENTS.

THIS DRAWING CONTAINS INFORMATION THAT IS PROPRIETARY TO MOLEX ELECTRONIC TECHNOLOGIES, LLC AND SHOULD NOT BE USED WITHOUT WRITTEN PERMISSION

DIMENSION UNITS	SCALE	CURRENT REV DESC: OBSOLETE PART NO	
MM/IN	4:1		
GENERAL TOLERANCES (UNLESS SPECIFIED)			
	MM	INCH	
4 PLACES	±	±	
3 PLACES	±	± 0.01	
2 PLACES	±	± 0.014	
1 PLACE	±	± 0.035	
0 PLACES	±	±	
ANGULAR TOL	±	± 0.5°	
DRAFT WHERE APPLICABLE MUST REMAIN WITHIN DIMENSIONS		THIRD ANGLE PROJECTION	DRAWING
			D-SIZE
		SERIES	44516
		MATERIAL NUMBER	SEE TABLE
		CUSTOMER	GENERAL MARKET
		SHEET NUMBER	1 OF 2

molex

PANEL-MOUNT RECEPTACLE, 4-16 CKT. BLIND MATE, MINI-FIT SLIDE 'N' LOCK

PRODUCT CUSTOMER DRAWING

DOCUMENT NUMBER: SD-44516-004
DOC TYPE: PSD
DOC PART: 000
REVISION: C

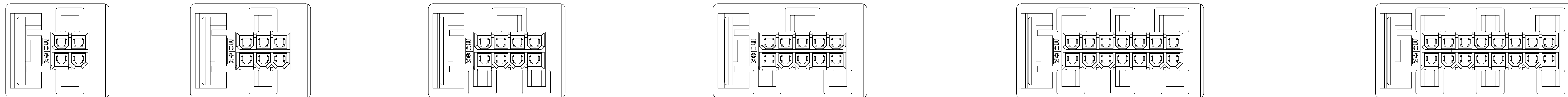

4 CIRCUIT

6 CIRCUIT

8 CIRCUIT

10 CIRCUIT

14 CIRCUIT

16 CIRCUIT

RECOMMENDED PANEL CUTOUTS
VIEWED FROM MATING SIDE

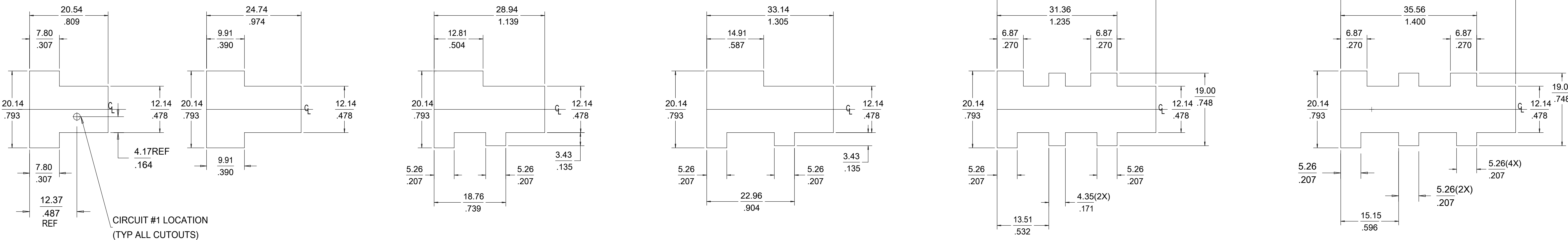
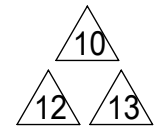

CIRCUIT #1 LOCATION
(TYP ALL CUTOUTS)

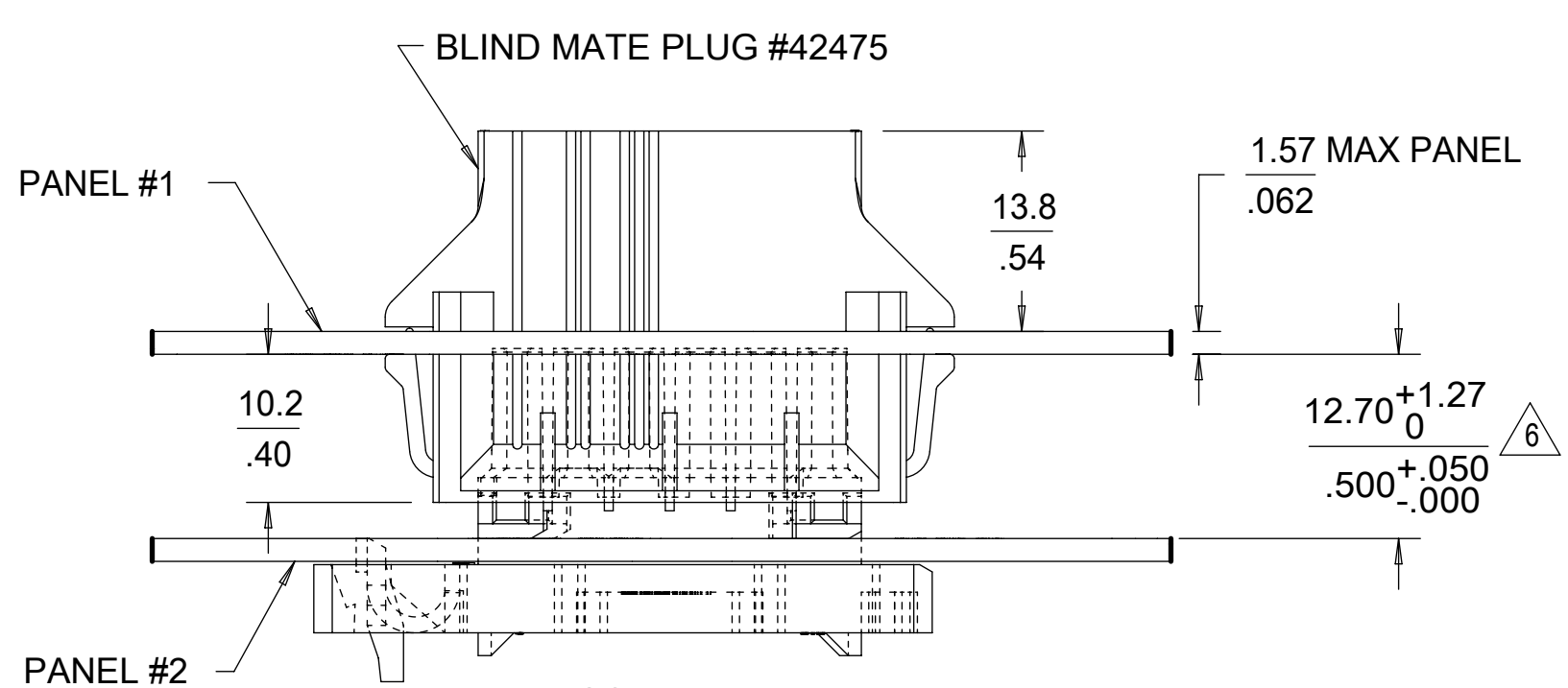

SCALE 2:1
PANEL-TO-PANEL
APPLICATION #1

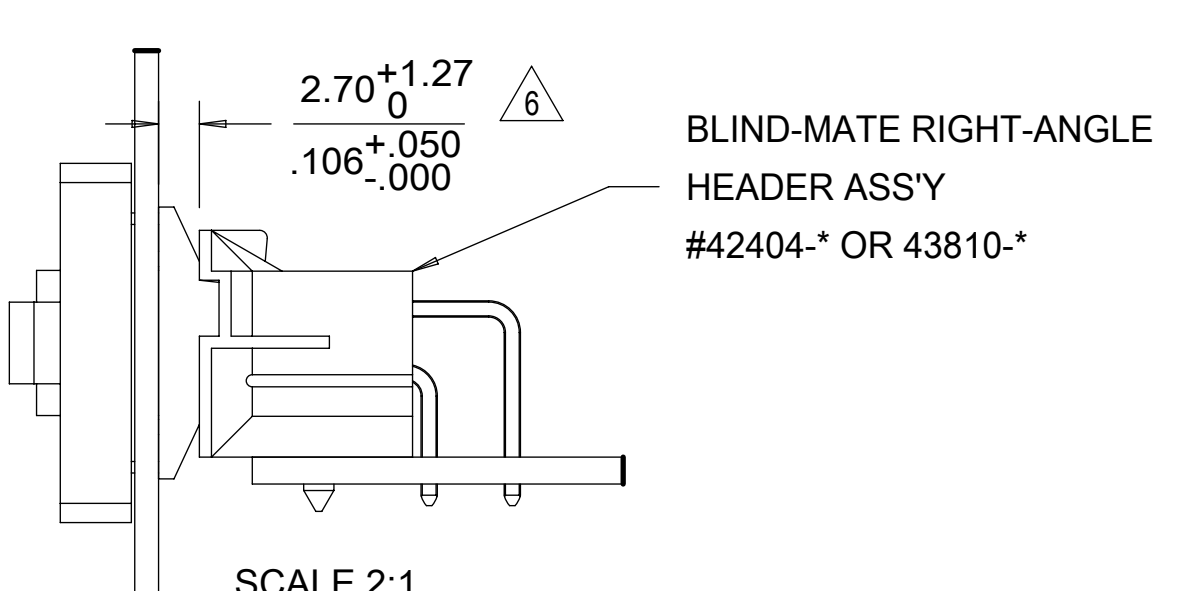

SCALE 2:1
PANEL-TO-P.C. BOARD
APPLICATION #3

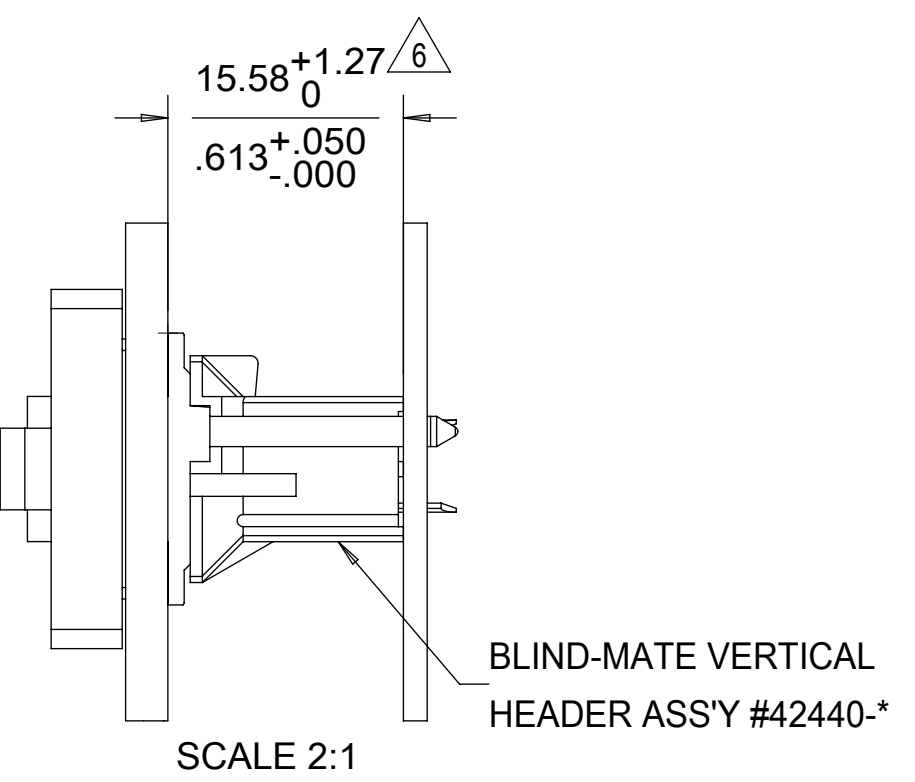
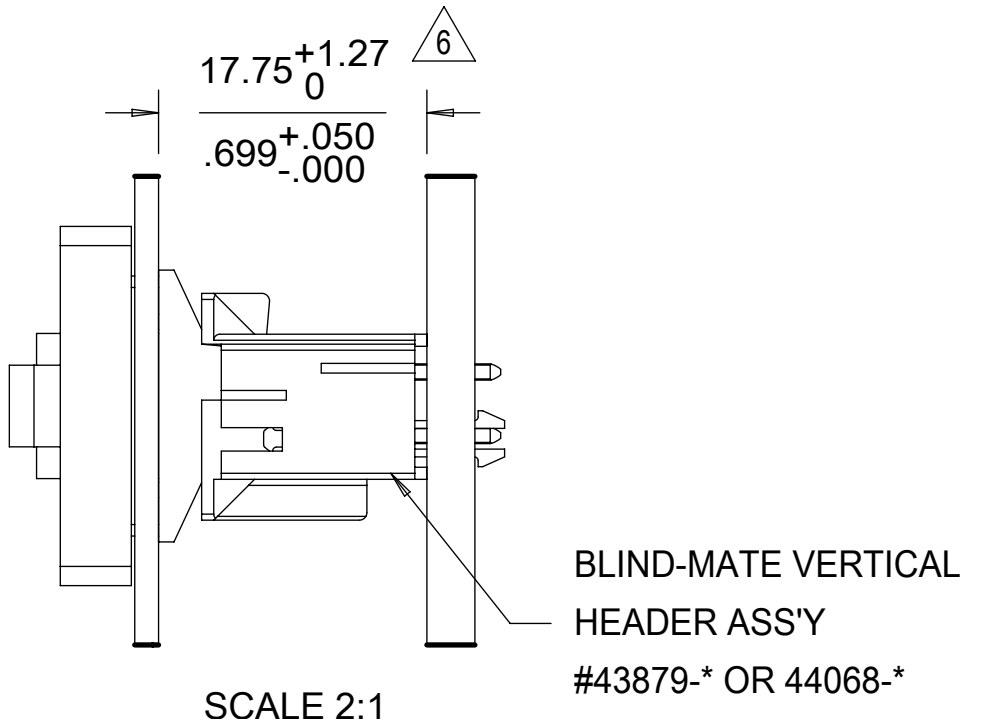
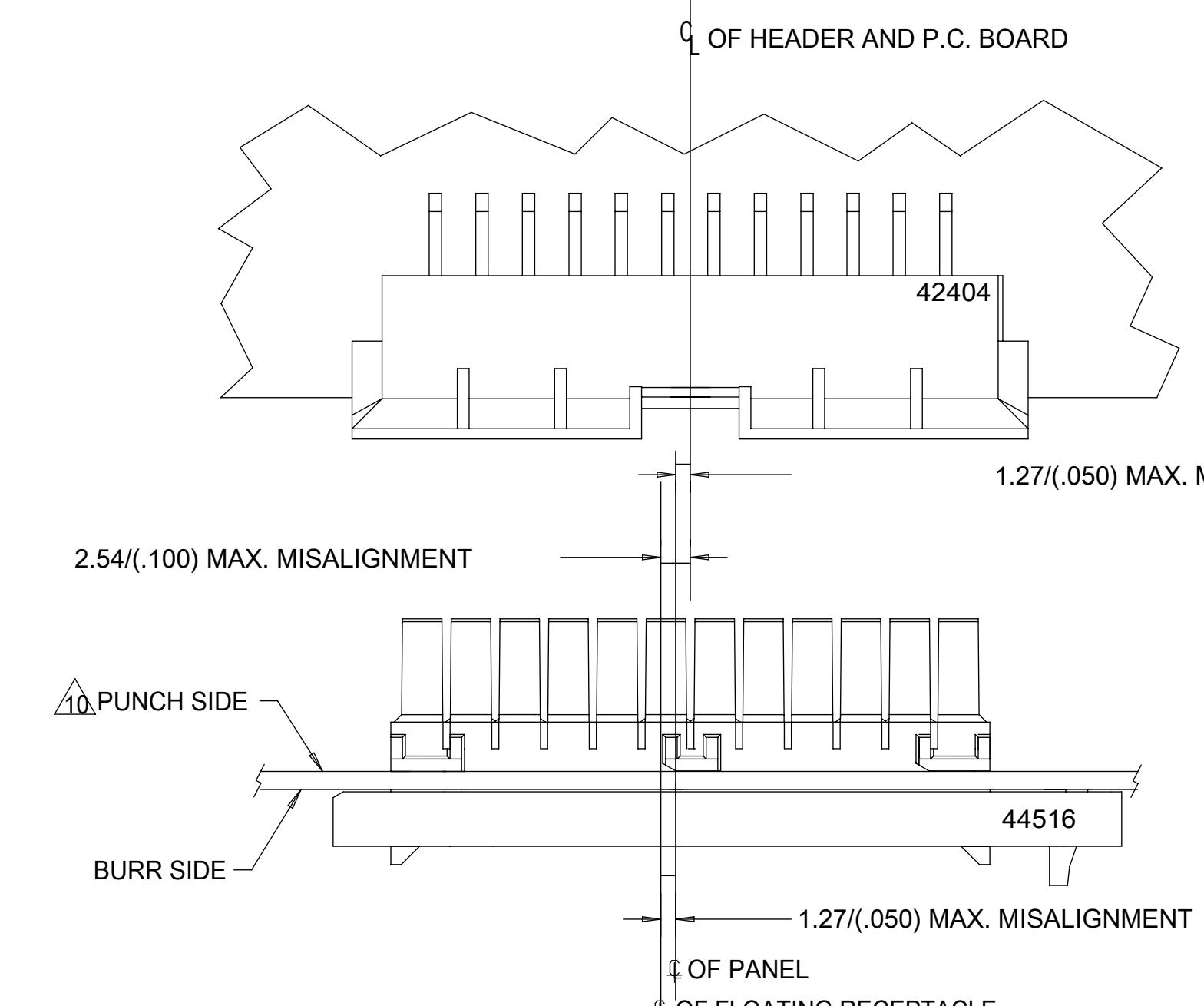

SCALE 2:1
PANEL-TO-P.C. BOARD
APPLICATION #2

SCALE 2:1
PANEL-TO-P.C. BOARD
APPLICATION #4

ALIGNMENT TOLERANCES FOR 1.27/(.050) MAX. BOARD TO PANEL MISALIGNMENT
±1.27/(.050) RECEPTACLE FLOAT.

THIS DRAWING CONTAINS INFORMATION THAT IS PROPRIETARY TO MOLEX ELECTRONIC TECHNOLOGIES, LLC AND SHOULD NOT BE USED WITHOUT WRITTEN PERMISSION			
DIMENSION UNITS	SCALE	CURRENT REV DESC: OBSOLETE PART NO	
MM/IN	2:1		
GENERAL TOLERANCES (UNLESS SPECIFIED)			
	MM	INCH	
4 PLACES	±	±	EC NO: 608605
3 PLACES	±	± 0.01	DRWN: AKUMAR19 2018/11/26
2 PLACES	± 0.25	± 0.014	CHK'D: GGA 2019/06/06
1 PLACE	± 0.35	±	APPR: GGA 2019/06/06
0 PLACES	±	±	INITIAL REVISION:
ANGULAR TOL	± 0.5°		DRWN: HRIBAR 2001/08/21
			APPR: MARGULIS 2001/08/21
DRAFT WHERE APPLICABLE MUST REMAIN WITHIN DIMENSIONS	THIRD ANGLE PROJECTION	DRAWING	SERIES
		D-SIZE	44516
DOCUMENT NUMBER		DOC TYPE	DOC PART
SD-44516-004		PSD	000
CUSTOMER		REVISION	
GENERAL MARKET		C	
MATERIAL NUMBER		SHEET NUMBER	
SEE TABLE		2 OF 2	