



900 MHz Cavity Bandpass Filter

Part Number: AB915B528



ANATECH ELECTRONICS INC
RF & Microwave Filters & Products

Electrical specifications

- Center Frequency:** 910-920 MHz
- Insertion loss :** ≤ 1.5 dB
- Return loss:** ≥ 16 dB
- Out of band rejection 1:** 75 dB@850-894 MHz
- Out of band rejection 2:** 75 dB@935-950 MHz
- Power Handling:** 20 Watts

Mechanical

- Mounting Method:** Threaded Mounting Holes
- Connector Type:** N Female
- Dimensions:** 4.72" X 2.36" X 1.89" in

Environmental

- Operating Temperature:** -45 to +85° C
- Storage Temperature:** -55 to +95° C
- Shock:** 20 G. 11ms
- Vibration:** 20 G. 5 to 200 MHz

Outline Drawing:

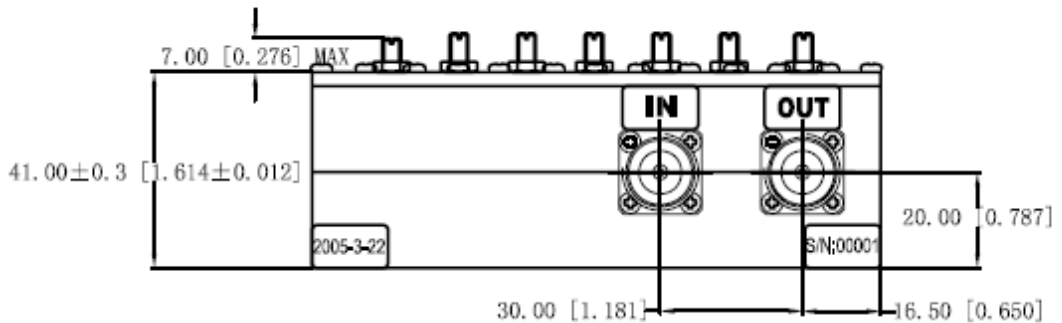
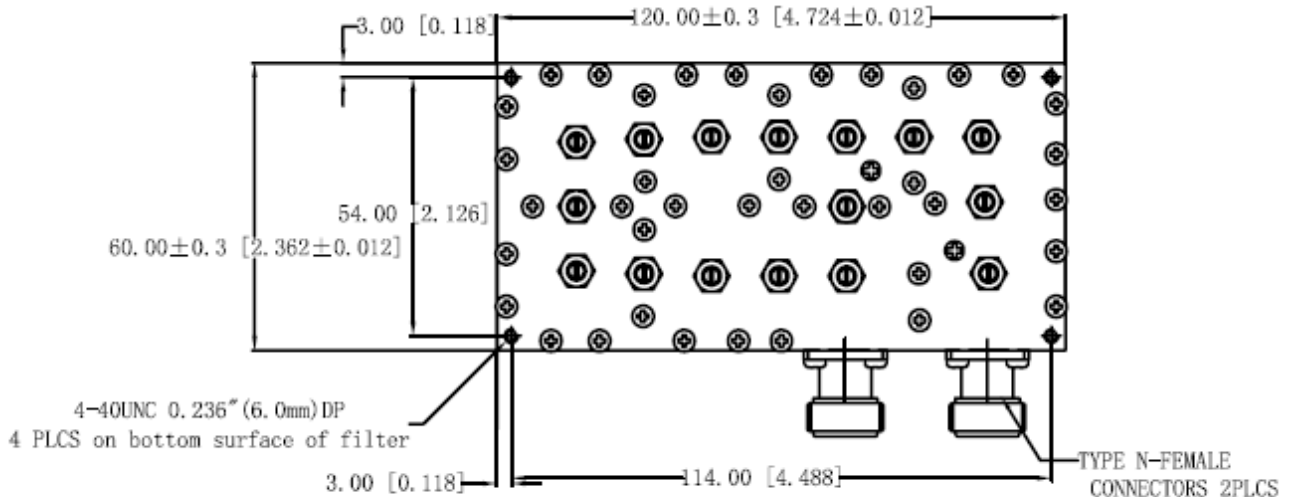



900 MHz Cavity Bandpass Filter

Part Number: AB915B528



Plot:

