



# STS17NH3LL

N-channel 30 V - 0.004  $\Omega$  - 17 A - SO-8  
STripFET™ Power MOSFET for DC-DC conversion

## Features

Type	V <sub>DSS</sub>	R <sub>DS(on)</sub>	I <sub>D</sub>
STS17NH3LL	30V	<0.0057 $\Omega$	17A <sup>(1)</sup>

1. This value is rated according to R<sub>thj-pcb</sub>

- Optimal R<sub>DS(on)</sub> x Q<sub>g</sub> trade-off @ 4.5 V
- Conduction losses reduced
- Improved junction-case thermal resistance
- Low threshold device

## Applications

- Switching application

## Description

This device utilizes the latest advanced design rules of ST's proprietary STripFET™ technology. This process coupled to unique metallization techniques realizes the most advanced low voltage Power MOSFET in SO-8 ever produced.

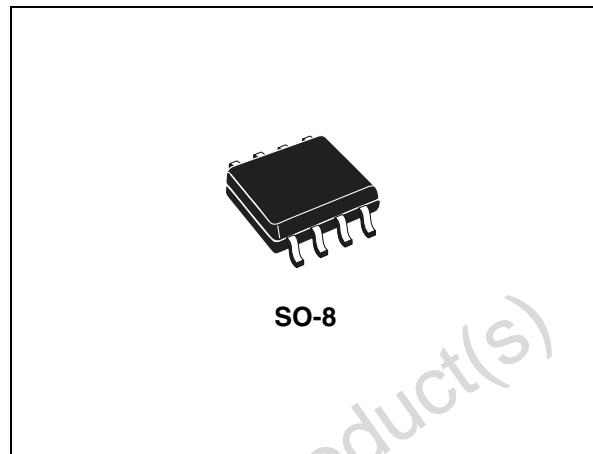

Figure 1. Internal schematic diagram

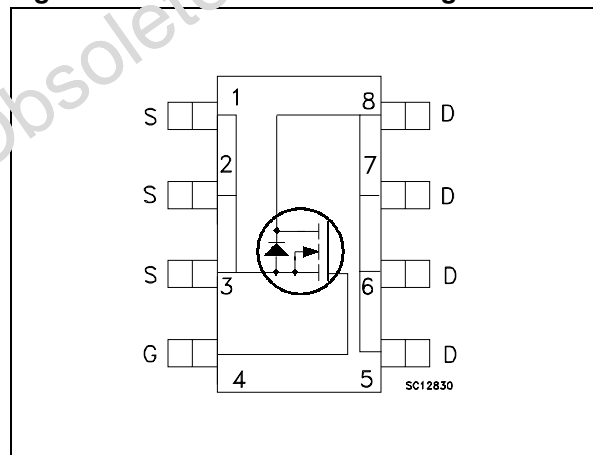

Table 1. Device summary

Order code	Marking	Package	Packaging
STS17NH3LL	17H3LL-	SO-8	Tape & reel

# Contents

<b>1</b>	<b>Electrical ratings</b> .....	<b>3</b>
<b>2</b>	<b>Electrical characteristics</b> .....	<b>4</b>
	2.1 Electrical characteristics (curves) .....	6
<b>3</b>	<b>Test circuit</b> .....	<b>8</b>
<b>4</b>	<b>Package mechanical data</b> .....	<b>9</b>
<b>5</b>	<b>Revision history</b> .....	<b>11</b>

Obsolete Product(s) - Obsolete Product(s)

# 1 Electrical ratings

**Table 2. Absolute maximum ratings**

Symbol	Parameter	Value	Unit
$V_{DS}$	Drain-source voltage ( $V_{GS} = 0$ )	30	V
$V_{GS}$	Gate- source voltage	$\pm 16$	V
$I_D^{(1)}$	Drain current (continuous) at $T_C = 25^\circ\text{C}$	17	A
$I_D$	Drain current (continuous) at $T_C = 100^\circ\text{C}$	10.6	A
$I_{DM}^{(2)}$	Drain current (pulsed)	68	A
$P_{tot}^{(1)}$	Total dissipation at $T_C = 25^\circ\text{C}$	2.7	W
$T_{stg}$	Storage temperature	-55 to 150	$^\circ\text{C}$
$T_j$	Operating junction temperature		

1. This value is rated according to  $R_{thj-pcb}$
2. Pulse width limited by safe operating area

**Table 3. Thermal resistance**

Symbol	Parameter	Value	Unit
$R_{thj-pcb}^{(1)}$	Thermal resistance junction-ambient max	47	$^\circ\text{C}/\text{W}$

1. When mounted on 1inch<sup>2</sup> FR-4 board, 2oz of Cu and  $t < 10\text{sec}$

**Table 4. Avalanche data**

Symbol	Parameter	Value	Unit
$I_{AV}$	Not-repetitive avalanche current	7.5	A
$E_{AS}$	Single pulse avalanche energy (starting $T_j=25^\circ\text{C}$ , $I_d=I_{AV}$ )	150	mJ

## 2 Electrical characteristics

( $T_{CASE}=25^{\circ}C$  unless otherwise specified)

**Table 5. On/off states**

Symbol	Parameter	Test conditions	Min	Typ.	Max	Unit
$V_{(BR)DSS}$	Drain-source breakdown voltage	$I_D = 250 \mu A, V_{GS} = 0$	30			V
$I_{DSS}$	Zero gate voltage drain current ( $V_{GS} = 0$ )	$V_{DS} = \text{Max rating}$ $V_{DS} = \text{Max rating @ } 125^{\circ}C$			1 10	$\mu A$ $\mu A$
$I_{GSS}$	Gate-body leakage current ( $V_{DS} = 0$ )	$V_{GS} = \pm 16 V$			$\pm 100$	nA
$V_{GS(th)}$	Gate threshold voltage	$V_{DS} = V_{GS}, I_D = 250 \mu A$	1			V
$R_{DS(on)}$	Static drain-source on resistance	$V_{GS} = 10 V, I_D = 8.5 A$ $V_{GS} = 4.5 V, I_D = 8.5 A$		0.004 0.005	0.0057 0.0075	$\Omega$ $\Omega$

**Table 6. Dynamic**

Symbol	Parameter	Test conditions	Min	Typ.	Max	Unit
$C_{iss}$ $C_{oss}$ $C_{rss}$	Input capacitance Output capacitance Reverse transfer capacitance	$V_{DS}=25 V, f=1 \text{ MHz}$ $V_{GS} = 0$		1810 565 41		pF pF pF
$Q_g$ $Q_{gs}$ $Q_{gd}$	Total gate charge Gate-source charge Gate-drain charge	$V_{DD}=15 V, I_D=17 A$ $V_{GS}=4.5 V$ (see Figure 14)		18 4.8 5.3	24	nC nC nC
$R_G$	Gate input resistance	f=1 MHz Gate DC Bias = 0 Test signal level = 20 mV open drain	0.5	1.5	3	$\Omega$

**Table 7. Switching times**

Symbol	Parameter	Test conditions	Min	Typ.	Max	Unit
$t_{d(on)}$ $t_r$	Turn-on delay time Rise time	$V_{DD} = 15\text{ V}$ , $I_D = 8.5\text{ A}$ $R_G = 4.7\ \Omega$ , $V_{GS} = 10\text{ V}$ (see Figure 16)		8 65		ns ns
$t_{d(off)}$ $t_f$	Turn-off delay time Fall time	$V_{DD} = 15\text{ V}$ , $I_D = 8.5\text{ A}$ $R_G = 4.7\ \Omega$ , $V_{GS} = 10\text{ V}$ (see Figure 16)		38 20		ns ns

**Table 8. Source drain diode**

Symbol	Parameter	Test conditions	Min	Typ.	Max	Unit
$I_{SD}$	Source-drain current				17	A
$I_{SDM}$	Source-drain current (pulsed)				68	A
$V_{SD}^{(1)}$	Forward on voltage	$I_{SD} = 17\text{ A}$ , $V_{GS} = 0$			1.3	V
$t_{rr}$	Reverse recovery time	$I_{SD} = 17\text{ A}$ , $di/dt = 100\text{ A}/\mu\text{s}$		22		ns
$Q_{rr}$	Reverse recovery charge	$V_{DD} = 15\text{ V}$ , $T_j = 25^\circ\text{C}$ (see Figure 15)		32		nC
$I_{RRM}$	Reverse recovery current			1.9		A

1. Pulsed: pulse duration=300 $\mu\text{s}$ , duty cycle 1.5%

## 2.1 Electrical characteristics (curves)

Figure 2. Safe operating area

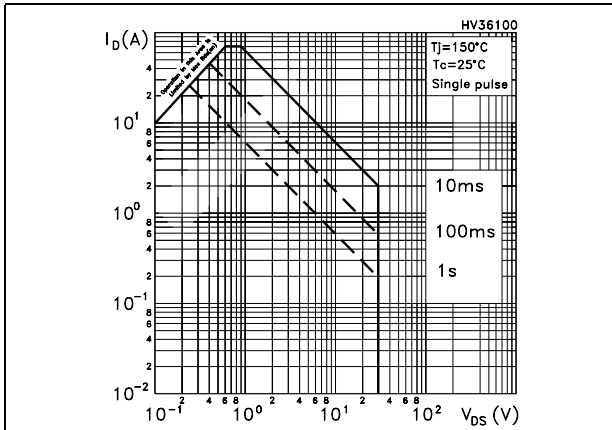

Figure 3. Thermal impedance

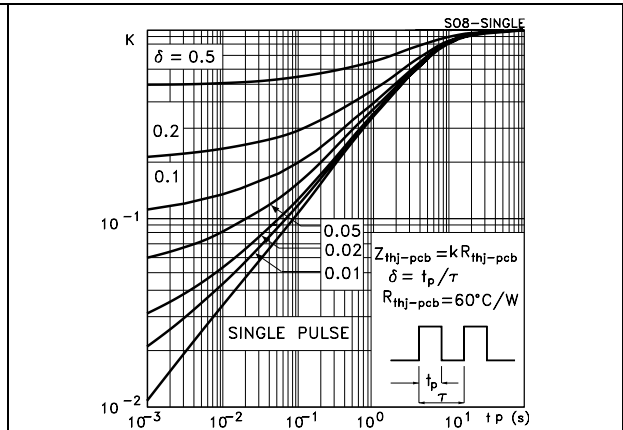

Figure 4. Output characteristics

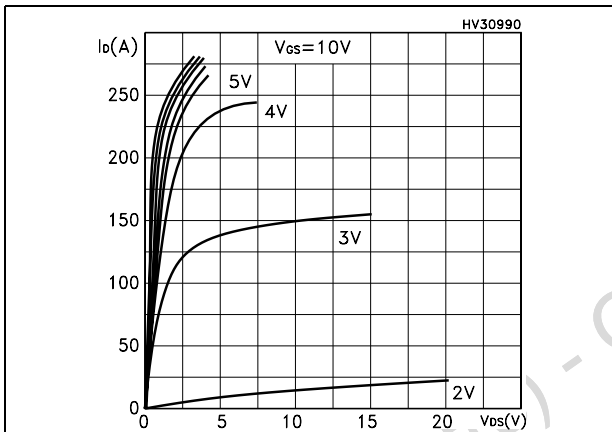

Figure 5. Transfer characteristics

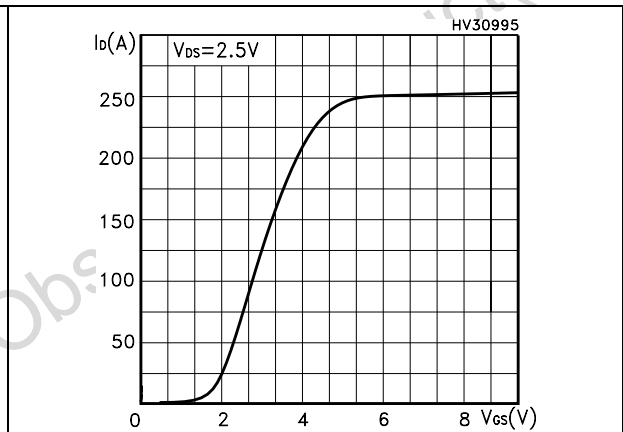

Figure 6. Normalized  $B_{V_{DS}}$  vs temperature

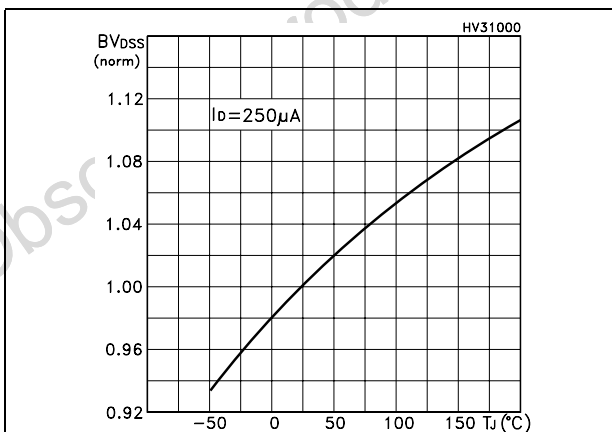

Figure 7. Static drain-source on resistance

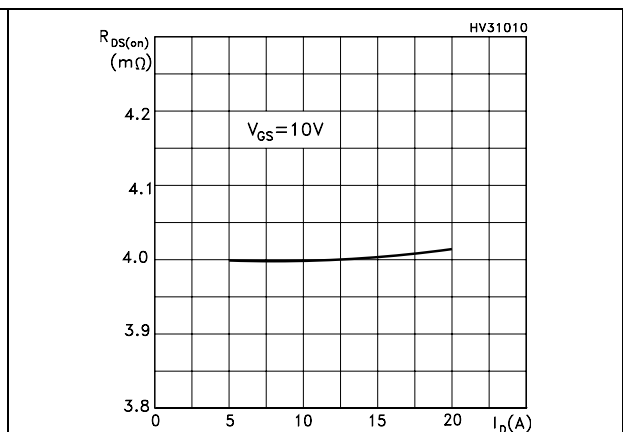

Figure 8. Gate charge vs gate-source voltage Figure 9. Capacitance variations

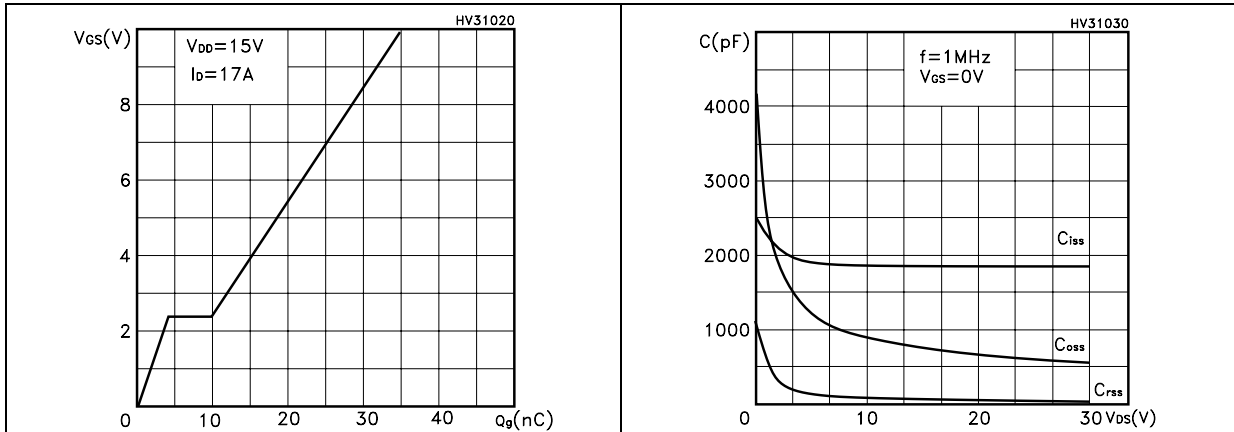

Figure 10. Normalized gate threshold voltage vs temperature Figure 11. Normalized on resistance vs temperature

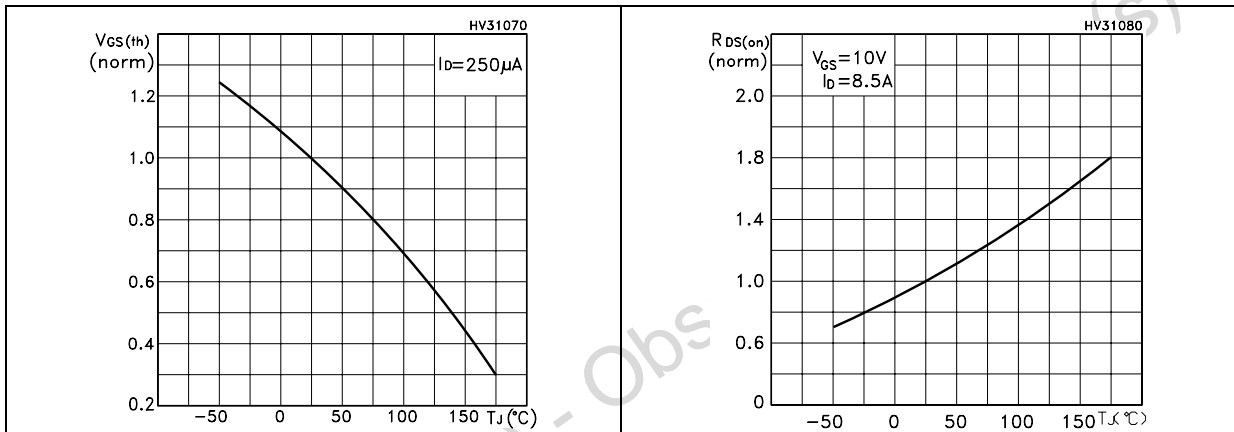
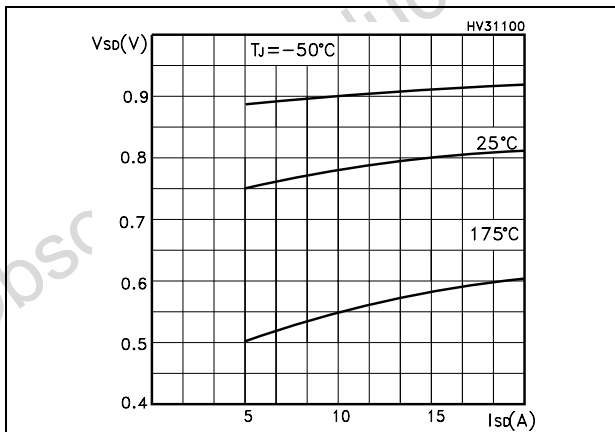

Figure 12. Source-drain diode forward characteristics



### 3 Test circuit

Figure 13. Switching times test circuit for resistive load

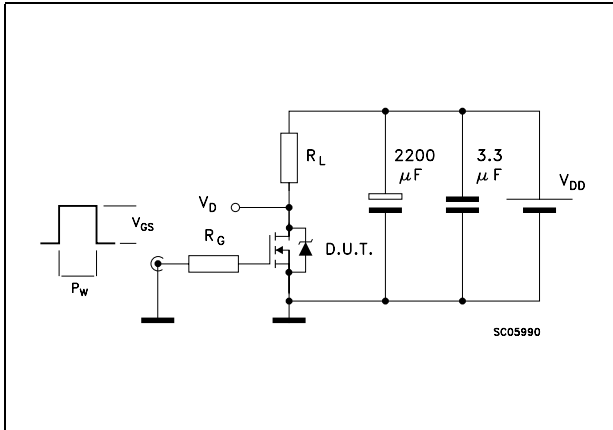

Figure 14. Gate charge test circuit

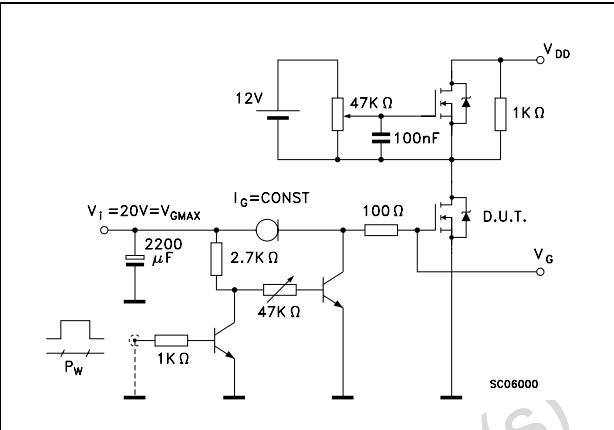

Figure 15. Test circuit for inductive load switching and diode recovery times

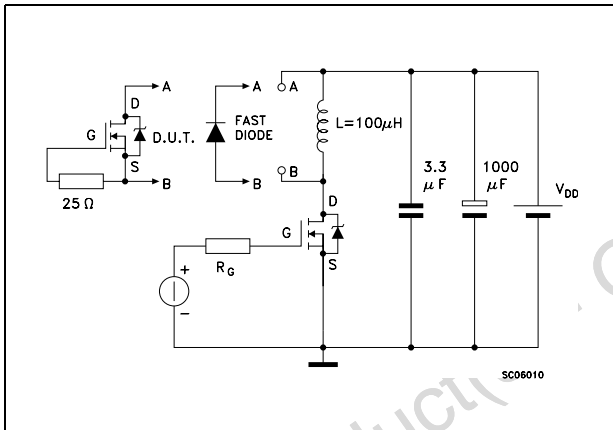

Figure 16. Unclamped inductive load test circuit

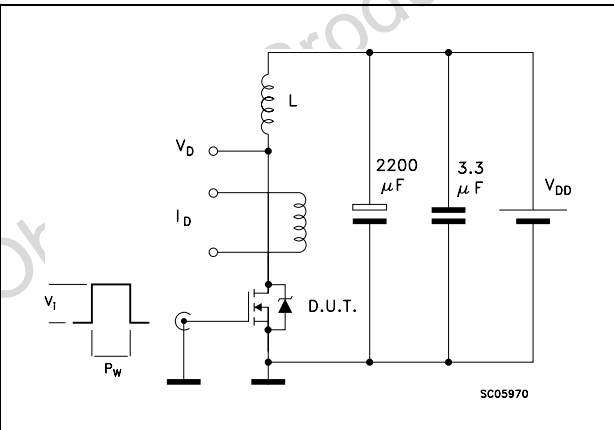

Figure 17. Unclamped inductive waveform

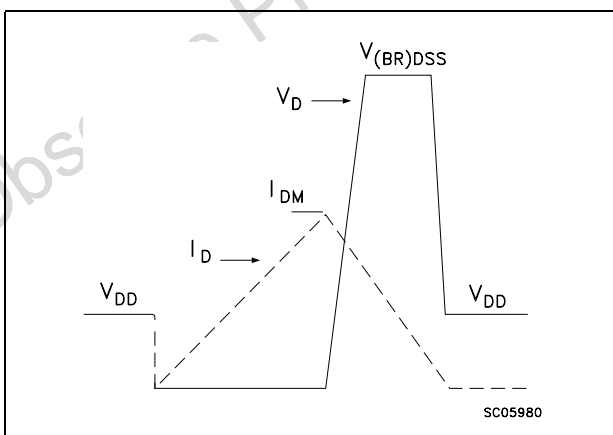
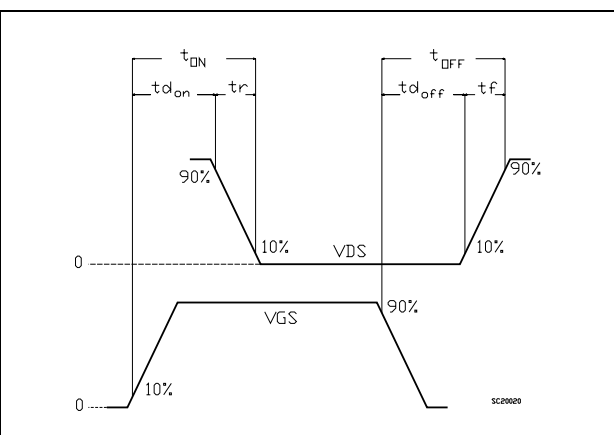

Figure 18. Switching time waveform





## 4 Package mechanical data

In order to meet environmental requirements, ST offers these devices in ECOPACK® packages. These packages have a lead-free second level interconnect . The category of second level interconnect is marked on the package and on the inner box label, in compliance with JEDEC Standard JESD97. The maximum ratings related to soldering conditions are also marked on the inner box label. ECOPACK is an ST trademark. ECOPACK specifications are available at: [www.st.com](http://www.st.com)

Obsolete Product(s) - Obsolete Product(s)

**SO-8 MECHANICAL DATA**

DIM.	mm.			inch		
	MIN.	TYP.	MAX.	MIN.	TYP.	MAX.
A			1.75			0.068
a1	0.1		0.25	0.003		0.009
a2			1.65			0.064
a3	0.65		0.85	0.025		0.033
b	0.35		0.48	0.013		0.018
b1	0.19		0.25	0.007		0.010
C	0.25		0.5	0.010		0.019
c1	45 (typ.)					
D	4.8		5.0	0.188		0.196
E	5.8		6.2	0.228		0.244
e		1.27			0.050	
e3		3.81			0.150	
F	3.8		4.0	0.14		0.157
L	0.4		1.27	0.015		0.050
M			0.6			0.023
S	8 (max.)					

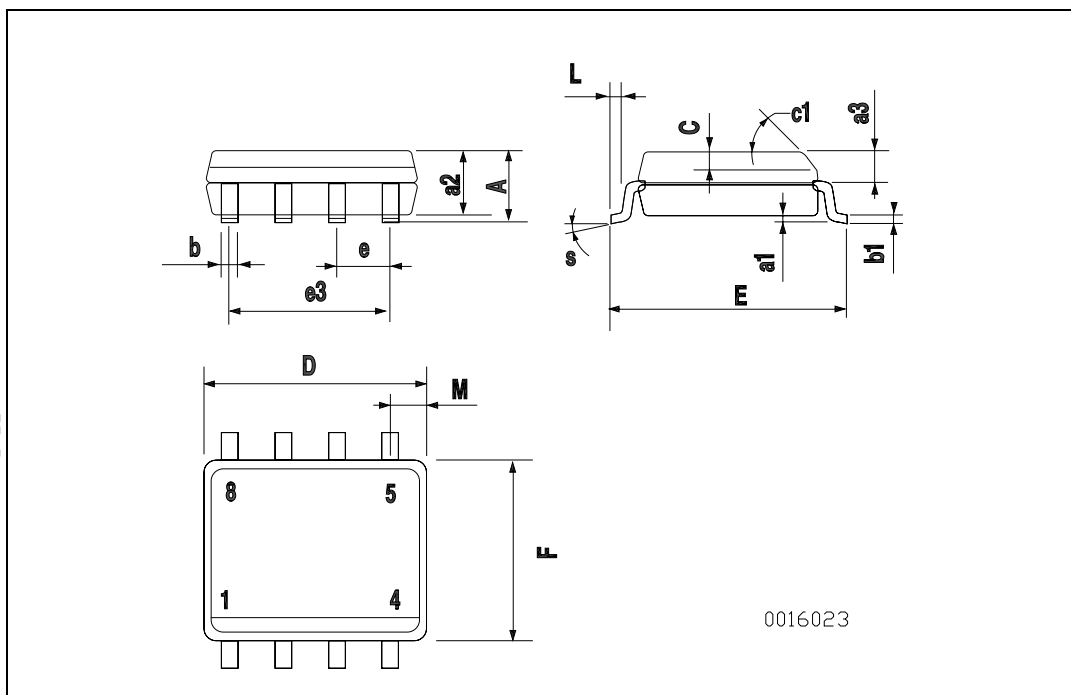

0016023

## 5 Revision history

**Table 9. Document revision history**

Date	Revision	Changes
01-Aug-2006	1	First release
09-Jan-2007	2	Complete version
12-Dec-2007	3	Inserted new <a href="#">Table 4: Avalanche data</a>

Obsolete Product(s) - Obsolete Product(s)

**Please Read Carefully:**

Information in this document is provided solely in connection with ST products. STMicroelectronics NV and its subsidiaries ("ST") reserve the right to make changes, corrections, modifications or improvements, to this document, and the products and services described herein at any time, without notice.

All ST products are sold pursuant to ST's terms and conditions of sale.

Purchasers are solely responsible for the choice, selection and use of the ST products and services described herein, and ST assumes no liability whatsoever relating to the choice, selection or use of the ST products and services described herein.

No license, express or implied, by estoppel or otherwise, to any intellectual property rights is granted under this document. If any part of this document refers to any third party products or services it shall not be deemed a license grant by ST for the use of such third party products or services, or any intellectual property contained therein or considered as a warranty covering the use in any manner whatsoever of such third party products or services or any intellectual property contained therein.

**UNLESS OTHERWISE SET FORTH IN ST'S TERMS AND CONDITIONS OF SALE ST DISCLAIMS ANY EXPRESS OR IMPLIED WARRANTY WITH RESPECT TO THE USE AND/OR SALE OF ST PRODUCTS INCLUDING WITHOUT LIMITATION IMPLIED WARRANTIES OF MERCHANTABILITY, FITNESS FOR A PARTICULAR PURPOSE (AND THEIR EQUIVALENTS UNDER THE LAWS OF ANY JURISDICTION), OR INFRINGEMENT OF ANY PATENT, COPYRIGHT OR OTHER INTELLECTUAL PROPERTY RIGHT.**

**UNLESS EXPRESSLY APPROVED IN WRITING BY AN AUTHORIZED ST REPRESENTATIVE, ST PRODUCTS ARE NOT RECOMMENDED, AUTHORIZED OR WARRANTED FOR USE IN MILITARY, AIR CRAFT, SPACE, LIFE SAVING, OR LIFE SUSTAINING APPLICATIONS, NOR IN PRODUCTS OR SYSTEMS WHERE FAILURE OR MALFUNCTION MAY RESULT IN PERSONAL INJURY, DEATH, OR SEVERE PROPERTY OR ENVIRONMENTAL DAMAGE. ST PRODUCTS WHICH ARE NOT SPECIFIED AS "AUTOMOTIVE GRADE" MAY ONLY BE USED IN AUTOMOTIVE APPLICATIONS AT USER'S OWN RISK.**

Resale of ST products with provisions different from the statements and/or technical features set forth in this document shall immediately void any warranty granted by ST for the ST product or service described herein and shall not create or extend in any manner whatsoever, any liability of ST.

ST and the ST logo are trademarks or registered trademarks of ST in various countries.

Information in this document supersedes and replaces all information previously supplied.

The ST logo is a registered trademark of STMicroelectronics. All other names are the property of their respective owners.

© 2007 STMicroelectronics - All rights reserved

STMicroelectronics group of companies

Australia - Belgium - Brazil - Canada - China - Czech Republic - Finland - France - Germany - Hong Kong - India - Israel - Italy - Japan - Malaysia - Malta - Morocco - Singapore - Spain - Sweden - Switzerland - United Kingdom - United States of America

[www.st.com](http://www.st.com)