

2:1 MIPI D-PHY (1.5 Gbps) 4 Data Lane Switch

FSA634

Description

The FSA634 is configured as a 4 data lane, MIPI D-PHY switch. This single pole double throw (SPDT) switch is optimized for switching between two high speed or low power MIPI sources. The FSA634 is designed for the MIPI specification and allows connection to a CSI or DSI module.

Features

- Switch Type: SPDT (10x)
- Signal Type: MIPI, D-PHY
- V_{CC} : 1.65 to 4.5 V
- Input Signal: 0 V to V_{CC}
- R_{ON} :
 - ◆ 5 Ω Typical HS MIPI
 - ◆ 5 Ω Typical LP MIPI
- ΔR_{ON} : 0.1 Ω Typical
- R_{ON_FLAT} : 0.06 Ω Typical
- I_{CCZ} : 0.5 μ A Maximum
- I_{CC} : 32 μ A Maximum
- O_{IRR} : -30 dB Typical
- Bandwidth: 1.9 GHz Typical
- Xtalk: -38 dB Typical
- C_{ON} : 4.3 pF Typical
- Skew: 3 ps Typical

Applications

- Cellular Phones, Smart Phones
- Tablets
- Laptops
- Displays



ON Semiconductor[®]

www.onsemi.com

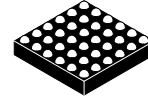

(Bottom View)

**WLCSP36,
2.06x2.06x0.432
CASE 567XU**

MARKING DIAGRAM



VJ = Specific Device Code
KK = Assembly Lot
X = Year
Y = Work Week
Z = Assembly Location

ORDERING INFORMATION

See detailed ordering and shipping information on page 7 of this data sheet.

FSA634

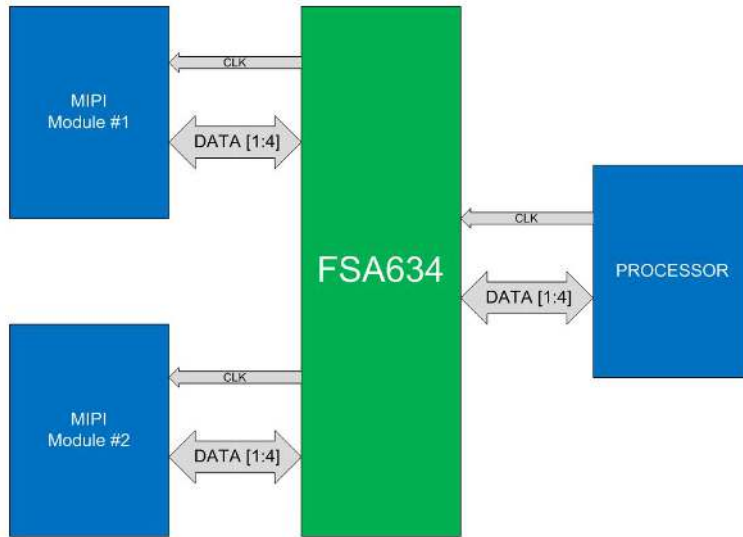
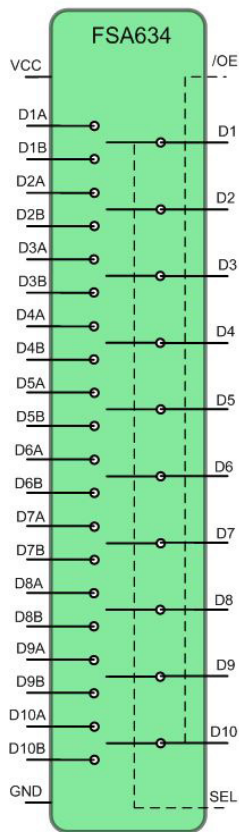

Figure 1. Typical Application

PIN DESCRIPTIONS



PIN NAME	DESCRIPTION		
Dn	Common Data Path		
DnA	Data Path A		
DnB	Data Path B		
/OE	Output Enable		
SEL	Control Pin	SEL=0	$\underline{Dn} = \underline{DnA}$
		SEL=1	$\underline{Dn} = \underline{DnB}$
VCC	Power		
GND	Ground		
NC	No Connect		

Figure 2. Analog Symbol

FSA634

PIN DEFINITIONS

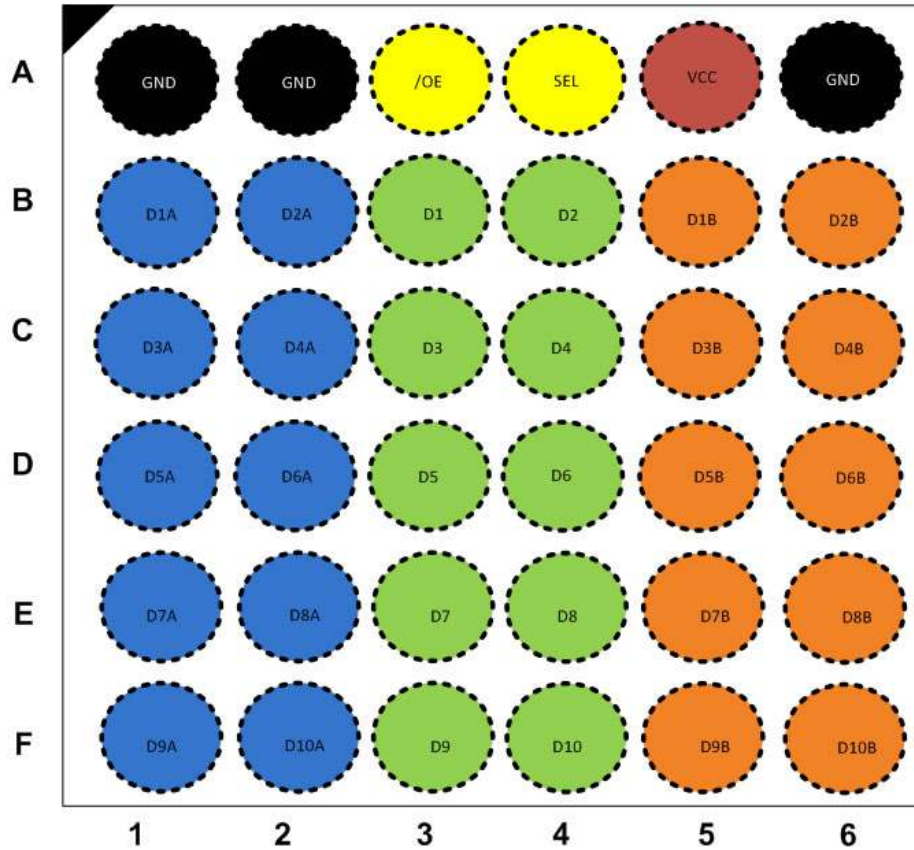

Figure 3. Top Through View

Table 1. BALL-TO-PIN MAPPINGS

Ball	Pin Name	Ball	Pin Name	Ball	Pin Name
A1	GND	C1	D3A	E1	D7A
A2	GND	C2	D4A	E2	D8A
A3	/OE	C3	D3	E3	D7
A4	SEL	C4	D4	E4	D8
A5	VCC	C5	D3B	E5	D7B
A6	GND	C6	D4B	E6	D8B
B1	D1A	D1	D5A	F1	D9A
B2	D2A	D2	D6A	F2	D10A
B3	D1	D3	D5	F3	D9
B4	D2	D4	D6	F4	D10
B5	D1B	D5	D5B	F5	D9B
B6	D2B	D6	D6B	F6	D10B

FSA634

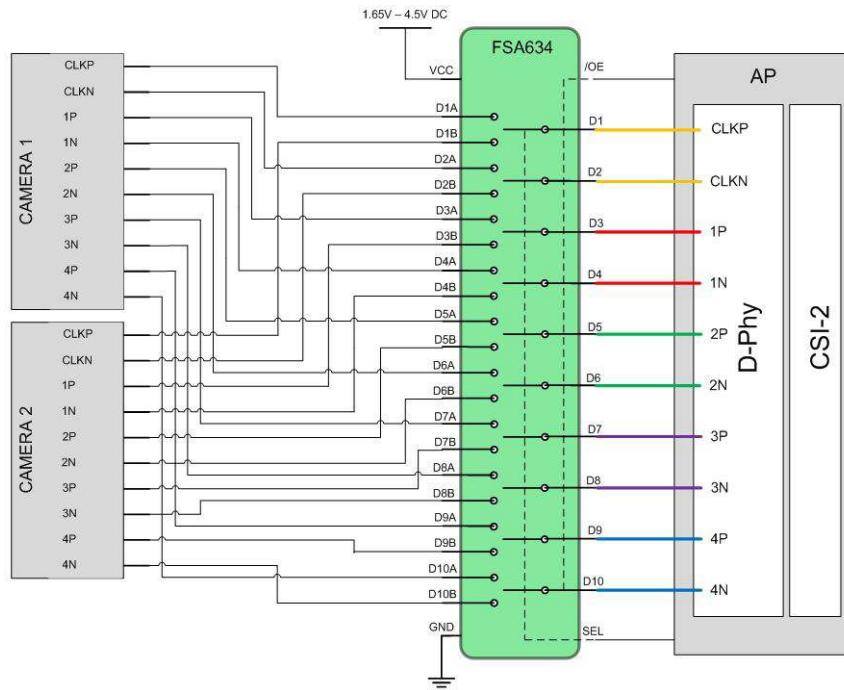

Figure 4. Suggested Configuration for 4 Lane D-PHY

TRUTH TABLE

SEL	/OE	Function
LOW	LOW	Dn = DnA
HIGH	LOW	Dn = DnB
X	HIGH	All Ports High Impedance

ABSOLUTE MAXIMUM RATINGS

Symbol	Parameter	Min	Max	Unit
V _{CC}	Supply Voltage	-0.5	5.25	V
V _{CNTRL}	DC Input Voltage (/OE, SEL)	-0.5	V _{CC}	V
V _{SW}	DC Switch I/O Voltage	-0.3	V _{CC}	V
I _{IK}	DC Input Diode Current	-50		mA
I _{OUT}	DC Output Current		50	mA
T _{STG}	Storage Temperature	-65	+150	°C
ESD	Human Body Model, JEDEC: JESD22-A114	All Pins		kV
	Charged Device Model, JEDEC: JESD22-C101	1.5		

Stresses exceeding those listed in the Maximum Ratings table may damage the device. If any of these limits are exceeded, device functionality should not be assumed, damage may occur and reliability may be affected.

1. The input and output negative ratings may be exceeded if the input and output diode current ratings are observed.
2. V_{SW} refers to analog data switch paths.

FSA634

RECOMMENDED OPERATING CONDITIONS

Symbol	Parameter	Min	Max	Unit	
V _{CC}	Supply Voltage	1.65	4.50	V	
V _{CNTRL}	Control Input Voltage (SEL, /OE) (Note 3)	0	V _{CC}	V	
V _{SW}	Switch I/O Voltage (Dn, DAn, DBn)	HS Mode	0	0.425	V
		LP Mode	0	1.3	V
T _A	Operating Temperature	-40	+85	°C	

Functional operation above the stresses listed in the Recommended Operating Ranges is not implied. Extended exposure to stresses beyond the Recommended Operating Ranges limits may affect device reliability.

3. The control inputs must be held HIGH or LOW; they must not float.

ELECTRICAL SPECIFICATION TABLE Typical values are at T_A = 25°C, V_{CC} = 3.3 V unless otherwise specified.

Symbol	Parameter	Conditions	Min	Typ	Max	Units
--------	-----------	------------	-----	-----	-----	-------

DC ELECTRICAL PARAMETERS

V _{IK}	Clamp Diode Voltage	I _{IN} = -18 mA, V _{CC} = 1.8 V			-1.2	V
V _{IH}	Input Voltage High	V _{CC} = 1.65 V to 4.50 V	1.0			V
V _{IL}	Input Voltage Low	V _{CC} = 1.65 V to 4.50 V			0.4	V
I _{IN}	Control Input Leakage (SEL, /OE)	V _{SW} = 0 V to V _{CC} , V _{CC} = 1.65 V to 4.50 V	-500		500	nA
I _{NO(OFF)} , I _{NC(OFF)}	Off Leakage Current of Port Dn, DnA, DnB	Dn = 0.3 V to V _{CC} - 0.3 V; DnA or DnB = Floating, 0.3 V, or V _{CC} - 0.3 V; /OE = 0 V; V _{CC} = 1.65 V to 4.5 V	-500		500	nA
I _{A(ON)}	On Leakage Current of Common Ports (Dn)	Dn = 0.3 V to V _{CC} - 0.3 V; DnA or DnB = Floating, 0.3 V, or V _{CC} - 0.3 V; /OE = 0 V; V _{CC} = 1.65 V to 4.5 V	-500		500	nA
I _{OFF}	Power-Off Leakage Current	Dn, DnA or DnB; V _{IN} = 0 V to 4.5 V; V _{CC} = 0 V	-500		500	nA
I _{OZ}	Off-State Leakage	0 ≤ Dn, DnA, DnB ≤ 3.6 V, /OE = High, V _{CC} = 4.5 V	-500		500	nA
R _{ON_MIPI_HS_1p8}	Switch On Resistance for HS MIPI Applications (Note 5)	I _{ON} = -10 mA, /OE = 0 V, SEL = V _{CC} or 0 V, DnA or DnB = 0.1 V, 0.2 V, 0.3 V, V _{CC} = 1.8 V		5	12	Ω
R _{ON_MIPI_HS_2p5}		I _{ON} = -10 mA, /OE = 0 V, SEL = V _{CC} or 0 V, DnA or DnB = 0.1 V, 0.2 V, 0.3 V, V _{CC} = 2.5 V		5	9	Ω
R _{ON_MIPI_HS_3p6}		I _{ON} = -10 mA, /OE = 0 V, SEL = V _{CC} or 0 V, DnA or DnB = 0.1 V, 0.2 V, 0.3 V, V _{CC} = 3.6 V		5	9	Ω
R _{ON_MIPI_HS_4p5}		I _{ON} = -10 mA, /OE = 0 V, SEL = V _{CC} or 0 V, DnA or DnB = 0.1 V, 0.2 V, 0.3 V, V _{CC} = 4.5 V		5	9	Ω
R _{ON_MIPI_LP_1p8}	Switch On Resistance for LP MIPI Applications (Note 5)	I _{ON} = -10 mA, /OE = 0 V, SEL = V _{CC} or 0 V, DnA or DnB = 0 V, 0.6 V, 1.2 V, V _{CC} = 1.8 V		5	12	Ω
R _{ON_MIPI_LP_2p5}		I _{ON} = -10 mA, /OE = 0 V, SEL = V _{CC} or 0 V, DnA or DnB = 0 V, 0.6 V, 1.2 V, V _{CC} = 2.5 V		5	9	Ω
R _{ON_MIPI_LP_3p6}		I _{ON} = -10 mA, /OE = 0 V, SEL = V _{CC} or 0 V, DnA or DnB = 0 V, 0.6 V, 1.2 V, V _{CC} = 3.6 V		5	9	Ω
R _{ON_MIPI_LP_4p5}		I _{ON} = -10 mA, /OE = 0 V, SEL = V _{CC} or 0 V, DnA or DnB = 0 V, 0.6 V, 1.2 V, V _{CC} = 4.5 V		5	9	Ω

FSA634

ELECTRICAL SPECIFICATION TABLE Typical values are at $T_A = 25^\circ\text{C}$, $V_{CC} = 3.3\text{ V}$ unless otherwise specified.

Symbol	Parameter	Conditions	Min	Typ	Max	Units
DC ELECTRICAL PARAMETERS						
$\Delta R_{ON_MIPI_HS_1p8}$	On Resistance Matching Between HS MIPI Channels	$I_{ON} = -10\text{ mA}$, $/OE = 0\text{ V}$, $SEL = V_{CC}$ or 0 V , DnA or $DnB = 0.1\text{ V}, 0.2\text{ V}, 0.3\text{ V}$, $V_{CC} = 1.8\text{ V}$		0.10		Ω
$\Delta R_{ON_MIPI_HS_2p5}$		$I_{ON} = -10\text{ mA}$, $/OE = 0\text{ V}$, $SEL = V_{CC}$ or 0 V , DnA or $DnB = 0.1\text{ V}, 0.2\text{ V}, 0.3\text{ V}$, $V_{CC} = 2.5\text{ V}$		0.10		Ω
$\Delta R_{ON_MIPI_HS_3p6}$		$I_{ON} = -10\text{ mA}$, $/OE = 0\text{ V}$, $SEL = V_{CC}$ or 0 V , DnA or $DnB = 0.1\text{ V}, 0.2\text{ V}, 0.3\text{ V}$, $V_{CC} = 3.6\text{ V}$		0.10		Ω
$\Delta R_{ON_MIPI_HS_4p5}$		$I_{ON} = -10\text{ mA}$, $/OE = 0\text{ V}$, $SEL = V_{CC}$ or 0 V , DnA or $DnB = 0.1\text{ V}, 0.2\text{ V}, 0.3\text{ V}$, $V_{CC} = 4.5\text{ V}$		0.10		Ω
$\Delta R_{ON_MIPI_LP_1p8}$	On Resistance Matching Between LP MIPI Channels	$I_{ON} = -10\text{ mA}$, $/OE = 0\text{ V}$, $SEL = V_{CC}$ or 0 V , DnA or $DnB = 0.0\text{ V}, 0.6\text{ V}, 1.2\text{ V}$, $V_{CC} = 1.8\text{ V}$		0.12		Ω
$\Delta R_{ON_MIPI_LP_2p5}$		$I_{ON} = -10\text{ mA}$, $/OE = 0\text{ V}$, $SEL = V_{CC}$ or 0 V , DnA or $DnB = 0.0\text{ V}, 0.6\text{ V}, 1.2\text{ V}$, $V_{CC} = 2.5\text{ V}$		0.12		Ω
$\Delta R_{ON_MIPI_LP_3p6}$		$I_{ON} = -10\text{ mA}$, $/OE = 0\text{ V}$, $SEL = V_{CC}$ or 0 V , DnA or $DnB = 0.0\text{ V}, 0.6\text{ V}, 1.2\text{ V}$, $V_{CC} = 3.6\text{ V}$		0.12		Ω
$\Delta R_{ON_MIPI_LP_4p5}$		$I_{ON} = -10\text{ mA}$, $/OE = 0\text{ V}$, $SEL = V_{CC}$ or 0 V , DnA or $DnB = 0.0\text{ V}, 0.6\text{ V}, 1.2\text{ V}$, $V_{CC} = 4.5\text{ V}$		0.12		Ω
$R_{ON_FLAT_MIPI_HS_1p8}$	On Resistance Flatness for HS MIPI Signals	$I_{ON} = -10\text{ mA}$, $/OE = 0\text{ V}$, $SEL = V_{CC}$ or 0 V , DnA or $DnB = 0.1\text{ V}, 0.2\text{ V}, 0.3\text{ V}$, $V_{CC} = 1.8\text{ V}$		0.04		Ω
$R_{ON_FLAT_MIPI_HS_2p5}$		$I_{ON} = -10\text{ mA}$, $/OE = 0\text{ V}$, $SEL = V_{CC}$ or 0 V , DnA or $DnB = 0.1\text{ V}, 0.2\text{ V}, 0.3\text{ V}$, $V_{CC} = 2.5\text{ V}$		0.06		Ω
$R_{ON_FLAT_MIPI_HS_3p6}$		$I_{ON} = -10\text{ mA}$, $/OE = 0\text{ V}$, $SEL = V_{CC}$ or 0 V , DnA or $DnB = 0.1\text{ V}, 0.2\text{ V}, 0.3\text{ V}$, $V_{CC} = 3.6\text{ V}$		0.06		Ω
$R_{ON_FLAT_MIPI_HS_4p5}$		$I_{ON} = -10\text{ mA}$, $/OE = 0\text{ V}$, $SEL = V_{CC}$ or 0 V , DnA or $DnB = 0.1\text{ V}, 0.2\text{ V}, 0.3\text{ V}$, $V_{CC} = 4.5\text{ V}$		0.06		Ω
$R_{ON_FLAT_MIPI_LP_1p8}$	On Resistance Flatness for LP MIPI Signals	$I_{ON} = -10\text{ mA}$, $/OE = 0\text{ V}$, $SEL = V_{CC}$ or 0 V , DnA or $DnB = 0.0\text{ V}, 0.6\text{ V}, 1.2\text{ V}$, $V_{CC} = 1.8\text{ V}$		0.18		Ω
$R_{ON_FLAT_MIPI_LP_2p5}$		$I_{ON} = -10\text{ mA}$, $/OE = 0\text{ V}$, $SEL = V_{CC}$ or 0 V , DnA or $DnB = 0.0\text{ V}, 0.6\text{ V}, 1.2\text{ V}$, $V_{CC} = 2.5\text{ V}$		0.28		Ω
$R_{ON_FLAT_MIPI_LP_3p6}$		$I_{ON} = -10\text{ mA}$, $/OE = 0\text{ V}$, $SEL = V_{CC}$ or 0 V , DnA or $DnB = 0.0\text{ V}, 0.6\text{ V}, 1.2\text{ V}$, $V_{CC} = 3.6\text{ V}$		0.28		Ω
$R_{ON_FLAT_MIPI_LP_4p5}$		$I_{ON} = -10\text{ mA}$, $/OE = 0\text{ V}$, $SEL = V_{CC}$ or 0 V , DnA or $DnB = 0.0\text{ V}, 0.6\text{ V}, 1.2\text{ V}$, $V_{CC} = 4.5\text{ V}$		0.28		Ω
I_{CCZ}	Quiescent Hi-Z Supply Current	$V_{IN} = 0\text{ V}$ or V_{CC} , $I_{OUT} = 0\text{ A}$, $V_{CC} = 4.5\text{ V}$			0.5	μA
I_{CC}	Quiescent Supply Current	$V_{IN} = 0$ or V_{CC} , $I_{OUT} = 0\text{ A}$, $V_{CC} = 2.5\text{ V}$ to 4.5 V		16	32	μA
I_{CC_1p8}		$V_{IN} = 0$ or V_{CC} , $I_{OUT} = 0\text{ A}$, $V_{CC} = 1.8\text{ V}$		15	25	μA
I_{CCT_4p5}	Increase in I_{CC} Current Per Control Voltage and V_{CC}	$V_{SEL} = 1.65\text{ V}$, $/OE = 1.65\text{ V}$, $V_{CC} = 4.5\text{ V}$			4	μA
I_{CCT_2p5}		$V_{SEL} = 1.65\text{ V}$, $/OE = 1.65\text{ V}$, $V_{CC} = 2.5\text{ V}$			0.1	μA

AC ELECTRICAL PARAMETERS

t_{INIT}	Initialization Time V_{CC} to Output	$R_L = 50\ \Omega$, $C_L = 5\text{ pF}$, $V_{SW} = 1.2\text{ V}$, $V_{CC} = 2.5\text{ V}$ to 4.5 V			100	μs
t_{INIT_1p8}		$R_L = 50\ \Omega$, $C_L = 5\text{ pF}$, $V_{SW} = 1.2\text{ V}$, $V_{CC} = 1.8\text{ V}$			150	μs
t_{EN}	Enable Turn-On Time, $/OE$ to Output	$R_L = 50\ \Omega$, $C_L = 5\text{ pF}$, $V_{SW} = 1.2\text{ V}$, $V_{CC} = 2.5\text{ V}$ to 4.5 V		120	200	ns
t_{EN_1p8}		$R_L = 50\ \Omega$, $C_L = 5\text{ pF}$, $V_{SW} = 1.2\text{ V}$, $V_{CC} = 1.8\text{ V}$		250	500	ns
t_{DIS}	Disable Turn-Off Time, $/OE$ to Output	$R_L = 50\ \Omega$, $C_L = 5\text{ pF}$, $V_{SW} = 1.2\text{ V}$, $V_{CC} = 2.5\text{ V}$ to 4.5 V		25	50	ns
t_{DIS_1p8}		$R_L = 50\ \Omega$, $C_L = 5\text{ pF}$, $V_{SW} = 1.2\text{ V}$, $V_{CC} = 1.8\text{ V}$		50	90	ns

FSA634

ELECTRICAL SPECIFICATION TABLE Typical values are at $T_A = 25^\circ\text{C}$, $V_{CC} = 3.3\text{ V}$ unless otherwise specified.

Symbol	Parameter	Conditions	Min	Typ	Max	Units
AC ELECTRICAL PARAMETERS						
t_{ON}	Turn-On Time, SEL to Output	$R_L = 50\ \Omega$, $C_L = 5\ \text{pF}$, $V_{SW} = 1.2\ \text{V}$, $V_{CC} = 2.5\ \text{V}$ to $4.5\ \text{V}$, SEL = H to L, SEL = L to H			200	ns
t_{ON_1p8}		$R_L = 50\ \Omega$, $C_L = 5\ \text{pF}$, $V_{SW} = 1.2\ \text{V}$, $V_{CC} = 1.8\ \text{V}$, SEL = H to L, SEL = L to H			300	ns
t_{OFF}	Turn-Off Time SEL to Output	$R_L = 50\ \Omega$, $C_L = 5\ \text{pF}$, $V_{SW} = 1.2\ \text{V}$, $V_{CC} = 2.5\ \text{V}$ to $4.5\ \text{V}$, SEL = H to L, SEL = L to H			200	ns
t_{OFF_1p8}		$R_L = 50\ \Omega$, $C_L = 5\ \text{pF}$, $V_{SW} = 1.2\ \text{V}$, $V_{CC} = 1.8\ \text{V}$, SEL = H to L, SEL = L to H			300	
t_{BBM}	Break-Before-Make Time	$R_L = 50\ \Omega$, $C_L = 5\ \text{pF}$, $V_{SW} = 1.2\ \text{V}$, $V_{CC} = 1.65\ \text{V}$ to $4.5\ \text{V}$	10	50		ns
OIRR	Off Isolation for MIPI (Note 5)	$R_L = 50\ \Omega$, $f = 750\ \text{MHz}$, $/OE = V_{CC}$, $V_{SW} = -1\ \text{dBm}$ (200 mV _{PP}), $V_{CC} = 1.65\ \text{V}$ to $4.5\ \text{V}$		-30		dB
XTALK	Crosstalk for MIPI (Note 5)	$R_L = 50\ \Omega$, $f = 750\ \text{MHz}$, $V_{SW} = -1\ \text{dBm}$ (200 mV _{PP}), $V_{CC} = 1.65\ \text{V}$ to $4.5\ \text{V}$		-38		dB
BW	Bandwidth at -3dB (Note 5)	$R_L = 50\ \Omega$, $C_L = 0\ \text{pF}$, $V_{CC} = 3\ \text{V}$		1.9		GHz
$t_{SK(O)}$	Channel-to-Channel Single-Ended Skew (Note 5)	TDR-Based Method ($V_{SW} = 0.2\ V_{PP}$, $C_L = C_{ON}$), $V_{CC} = 3.3\ \text{V}$		3	20	ps
$t_{SK(P)}$	Skew of Opposite Transitions of the Same Output (Note 5)	TDR-Based Method ($V_{SW} = 0.2\ V_{PP}$, $C_L = C_{ON}$), $V_{CC} = 3.3\ \text{V}$		3	20	ps

CAPACITANCE

C_{IN}	Control Pin Input Capacitance (Note 5)	$V_{CC} = 0\ \text{V}$, $f = 1\ \text{MHz}$		2.7		pF
C_{ON}	Out On Capacitance (Note 5)	$V_{CC} = 3.3\ \text{V}$, $/OE = 0\ \text{V}$, $f = 1\ \text{MHz}$		4.3		pF
C_{OFF}	Out Off Capacitance (Note 5)	V_{CC} and $/OE = 3.3\ \text{V}$, $f = 1\ \text{MHz}$		1.9		pF

Product parametric performance is indicated in the Electrical Characteristics for the listed test conditions, unless otherwise noted. Product performance may not be indicated by the Electrical Characteristics if operated under different conditions.

NOTE: Guarantee Levels:

4. Guaranteed by Design. Characterized on the ATE or Bench.
5. Guaranteed by Design and Characterization, not Production Tested.

The table below pertains to the Packaging information on the following page.

ORDERING INFORMATION

Part Number	Operating Temperature Range	Package	Top Mark
FSA634UCX	-40 to +85°C	36-Ball WLCSP, Non-JEDEC 2.06 x 2.06 mm, 0.35 mm Pitch	VJ



WLCSP36 2.06x2.06x0.432
CASE 567XU
ISSUE O

DATE 26 APR 2019

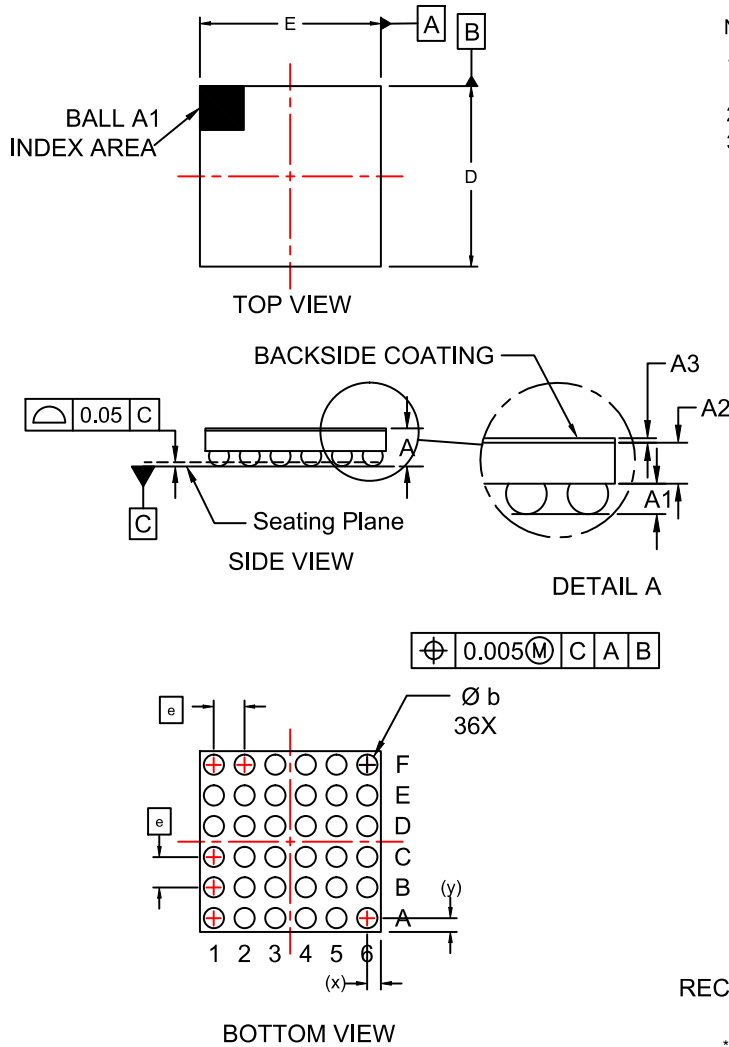

NOTES:

1. DIMENSIONING AND TOLERANCING PER ASME Y14.5M, 2009.
2. CONTROLLING DIMENSION: MILLIMETERS
3. DATUM C APPLIES TO THE SPHERICAL CROWN OF THE SOLDER BALLS

DIM	MILLIMETERS		
	MIN.	NOM.	MAX.
A	0.391	0.432	0.473
A1	0.154	0.174	0.194
A2	0.215	0.233	0.251
A3	0.022	0.025	0.028
b	0.211	0.231	0.251
D	2.03	2.06	2.09
E	2.03	2.06	2.09
e	0.35 BSC		
x	0.140	0.155	0.170
y	0.140	0.155	0.170

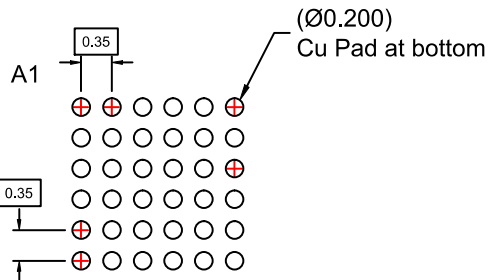

RECOMMENDED MOUNTING FOOTPRINT*
(NSMD PAD TYPE)

*FOR ADDITIONAL INFORMATION ON OUR Pb-FREE STRATEGY AND SOLDERING DETAILS, PLEASE DOWNLOAD THE ON SEMICONDUCTOR SOLDERING AND MOUNTING TECHNIQUES REFERENCE MANUAL, SOLDERRM/D.

DOCUMENT NUMBER:	98AON06820H	Electronic versions are uncontrolled except when accessed directly from the Document Repository. Printed versions are uncontrolled except when stamped "CONTROLLED COPY" in red.
DESCRIPTION:	WLCSP36 2.06x2.06x0.432	PAGE 1 OF 1

ON Semiconductor and ON are trademarks of Semiconductor Components Industries, LLC dba ON Semiconductor or its subsidiaries in the United States and/or other countries. ON Semiconductor reserves the right to make changes without further notice to any products herein. ON Semiconductor makes no warranty, representation or guarantee regarding the suitability of its products for any particular purpose, nor does ON Semiconductor assume any liability arising out of the application or use of any product or circuit, and specifically disclaims any and all liability, including without limitation special, consequential or incidental damages. ON Semiconductor does not convey any license under its patent rights nor the rights of others.

onsemi, **Onsemi**, and other names, marks, and brands are registered and/or common law trademarks of Semiconductor Components Industries, LLC dba "**onsemi**" or its affiliates and/or subsidiaries in the United States and/or other countries. **onsemi** owns the rights to a number of patents, trademarks, copyrights, trade secrets, and other intellectual property. A listing of **onsemi**'s product/patent coverage may be accessed at www.onsemi.com/site/pdf/Patent-Marking.pdf. **onsemi** reserves the right to make changes at any time to any products or information herein, without notice. The information herein is provided "as-is" and **onsemi** makes no warranty, representation or guarantee regarding the accuracy of the information, product features, availability, functionality, or suitability of its products for any particular purpose, nor does **onsemi** assume any liability arising out of the application or use of any product or circuit, and specifically disclaims any and all liability, including without limitation special, consequential or incidental damages. Buyer is responsible for its products and applications using **onsemi** products, including compliance with all laws, regulations and safety requirements or standards, regardless of any support or applications information provided by **onsemi**. "Typical" parameters which may be provided in **onsemi** data sheets and/or specifications can and do vary in different applications and actual performance may vary over time. All operating parameters, including "Typicals" must be validated for each customer application by customer's technical experts. **onsemi** does not convey any license under any of its intellectual property rights nor the rights of others. **onsemi** products are not designed, intended, or authorized for use as a critical component in life support systems or any FDA Class 3 medical devices or medical devices with a same or similar classification in a foreign jurisdiction or any devices intended for implantation in the human body. Should Buyer purchase or use **onsemi** products for any such unintended or unauthorized application, Buyer shall indemnify and hold **onsemi** and its officers, employees, subsidiaries, affiliates, and distributors harmless against all claims, costs, damages, and expenses, and reasonable attorney fees arising out of, directly or indirectly, any claim of personal injury or death associated with such unintended or unauthorized use, even if such claim alleges that **onsemi** was negligent regarding the design or manufacture of the part. **onsemi** is an Equal Opportunity/Affirmative Action Employer. This literature is subject to all applicable copyright laws and is not for resale in any manner.

ADDITIONAL INFORMATION

TECHNICAL PUBLICATIONS:

Technical Library: www.onsemi.com/design/resources/technical-documentation
onsemi Website: www.onsemi.com

ONLINE SUPPORT: www.onsemi.com/support

For additional information, please contact your local Sales Representative at www.onsemi.com/support/sales