

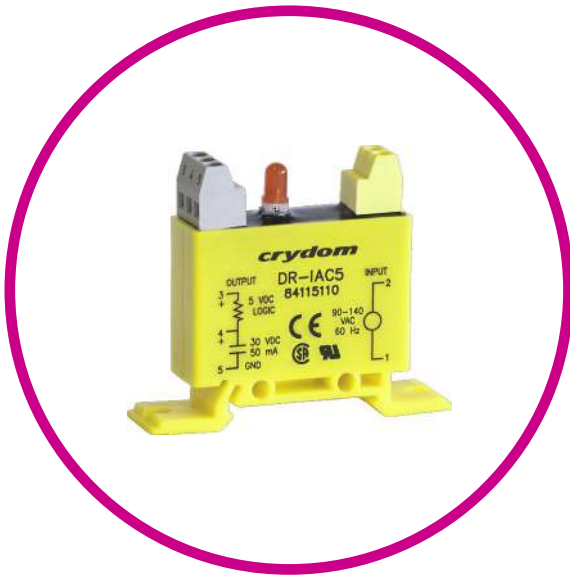

DR INPUT MODULE

I/O MODULE



Features

- DIN Rail Mountable Single Point Input Modules
- AC Inputs (Yellow Case)
- DC Inputs (White Case)
- kV Optical isolation
- Input and Output Barrier Strips Accept 14 to 2 AWG Wire
- Configured for Panel Mounting
- Open-Collector Output, with LED Status Indicator



SPECIFICATIONS ⁽¹⁾

Input

Part Number	DR-IAC5	DR-IAC5A	DR-IAC24	DR-IAC24A
Voltage Range	90-140 VAC/DC	180-280 VAC/DC	90-140 VAC/DC	180-280 VAC/DC
Maximum Current [mA] ⁽⁴⁾	6	5	6	5
Resistance [Ohms] ^{(2) (3)}	28 k	75 k	28 k	75 k
Drop-Out Current [mA] ⁽⁵⁾	2	1.5	2	1.5
Voltage for No Output [VAC/VDC] ⁽⁵⁾	50	50	50	50
Allowable Current [mA]	2.5	2	2.5	2

Output

Part Number	DR-IAC5	DR-IAC5A	DR-IAC24	DR-IAC24A
Maximum Voltage [VDC] ⁽⁹⁾	30	30	30	30
Maximum Voltage Drop [VDC] ⁽¹²⁾	0.2	0.2	0.2	0.2
Nominal Logic Supply Voltage [VDC]	5.0	5.0	5.0	5.0
Logic Supply Voltage Range [VDC]	3.0 - 6.0	3.0 - 6.0	20 - 30	20 - 30
Maximum Current [mA] ⁽¹⁰⁾	50	50	50	50
Maximum Logic Supply Current [mA] ⁽⁷⁾	28	28	28	28
Maximum Supply Leakage Current [μA] ⁽⁸⁾	10.0	10.0	10.0	10.0
Maximum Leakage Current [μA] ⁽¹¹⁾	10.0	10.0	10.0	10.0
Maximum Turn-On Time [msec] ⁽¹³⁾	20	20	20	20
Maximum Turn-Off Time [msec] ⁽¹³⁾	30	30	30	30

Input

Part Number	DR-IDC5	DR-IDC5A	DR-IDC24	DR-IDC24A
Voltage Range	4-32 VAC/DC	10-48 VAC/DC	4-32 VAC/DC	10-48 VAC/DC
Maximum Current [mA] ⁽⁴⁾	34	34	34	34
Resistance [Ohms] ^{(2) (3)}	1 k	2 k	1 k	2 k
Drop-Out Current [mA] ⁽⁵⁾	1	1	1	1
Voltage for No Output [VAC/VDC] ⁽⁵⁾	2	4	2	4
Allowable Current [mA]	1.5	1.5	1.5	1.5

Output

Part Number	DR-IDC5	DR-IDC5A	DR-IDC24	DR-IDC24A
Maximum Voltage [VDC] ⁽⁹⁾	30	30	30	30
Maximum Voltage Drop [VDC] ⁽¹²⁾	0.2	0.2	0.2	0.2
Nominal Logic Supply Voltage [VDC]	5.0	5.0	5.0	5.0
Logic Supply Voltage Range [VDC]	3.0 - 6.0	3.0 - 6.0	20 - 30	20 - 30
Maximum Current [mA] ⁽¹⁰⁾	50	50	50	50
Maximum Logic Supply Current [mA] ⁽⁷⁾	28	28	28	28
Maximum Supply Leakage Current [μA] ⁽⁸⁾	10.0	10.0	10.0	10.0
Maximum Leakage Current [μA] ⁽¹¹⁾	10.0	10.0	10.0	10.0
Maximum Turn-On Time [msec] ⁽¹³⁾	1.0	1.0	1.0	1.0
Maximum Turn-Off Time [msec] ⁽¹³⁾	1.0	1.0	1.0	1.0

General Specifications

Description	Parameters
Input / Output Isolation Voltage ⁽¹⁴⁾	4000 Vrms
Input / Output Capacitance	8 pF
Operating Temperature Range	-30 to 80°C
Storage Temperature Range	-40 to 100°C
Line Frequency Range	47 to 63 Hz
Weight (typical)	1.1 oz. (31.2g)



EQUIVALENT CIRCUIT BLOCK DIAGRAMS

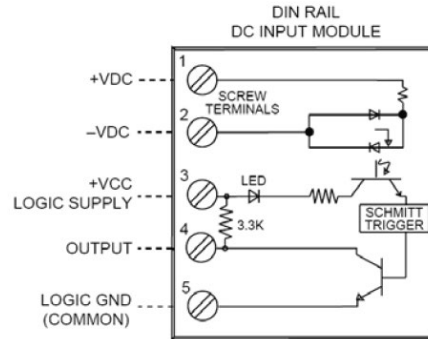
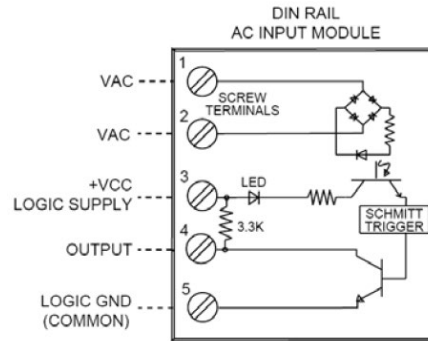

MECHANICAL SPECIFICATIONS

Tolerances: ± 0.02 in / 0.5 mm

All dimensions are in inches [millimeters]

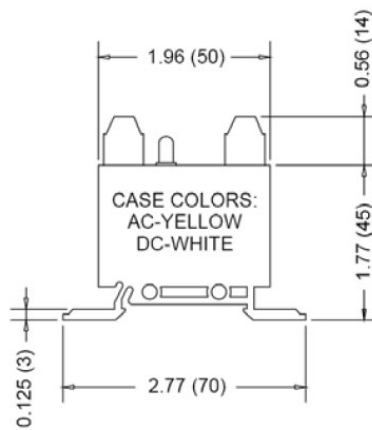
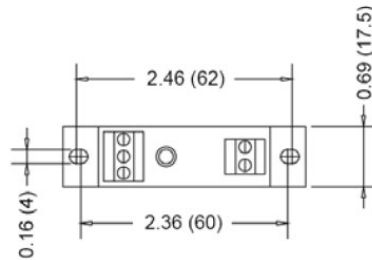



GENERAL NOTES

- (1) Specifications apply to an ambient temperature of -30 to 80 °C unless otherwise noted.
- (2) Resistance values for IAC modules are effective impedance values at 25 °C.
- (3) Resistance values are ±10% at 25 °C.
- (4) Measured at maximum specified input voltage, 25°C.
- (5) Defined as the maximum current allowed through the module's input to guarantee that the output will switch from "on" to "off".
Higher currents may result in the output remaining in the "on" state.
- (6) Defined as the maximum current allowed through the module's input that will not switch the module's output state from "off" to "on".
- (7) With external LED status indicator at maximum specified logic supply voltage and 25°C. 18mA without external LED.
- (8) At maximum specified logic voltage and 25°C.
- (9) Applied across open collector output transistor.
- (10) Sinking current through the open collector output transistor.
- (11) At maximum output voltage and 25°C.
- (12) At maximum output current and 25°C.
- (13) At nominal logic supply voltage, 25mA output sinking current, nominal input voltage and 25°C
- (14) At 25°C for 1 second maximum duration.

For additional information or specific questions, contact Sensata Technical Support.



AGENCY APPROVALS & CERTIFICATIONS



WARNINGS



RISK OF MATERIAL DAMAGE AND HOT ENCLOSURE

- The product's side panels may be hot, allow the product to cool before touching
- Follow proper mounting instructions including torque values
- Do not allow liquids or foreign objects to enter this product

Failure to follow these instructions can result in serious injury, or equipment damage.



HAZARD OF ELECTRIC SHOCK, EXPLOSION OR ARC FLASH

- Disconnect all power before installing or working with this equipment
- Verify all connections and replace all covers before turning on power

Failure to follow these instructions will result in death or serious injury.

Sensata Technologies, Inc. ("Sensata") data sheets are solely intended to assist designers ("Buyers") who are developing systems that incorporate Sensata products (also referred to herein as "components"). Buyer understands and agrees that Buyer remains responsible for using its independent analysis, evaluation and judgment in designing Buyer's systems and products. Sensata data sheets have been created using standard laboratory conditions and engineering practices. Sensata has not conducted any testing other than that specifically described in the published documentation for a particular data sheet. Sensata may make corrections, enhancements, improvements and other changes to its data sheets or components without notice.

Buyers are authorized to use Sensata data sheets with the Sensata component(s) identified in each particular data sheet. HOWEVER, NO OTHER LICENSE, EXPRESS OR IMPLIED, BY ESTOPPEL OR OTHERWISE TO ANY OTHER SENSATA INTELLECTUAL PROPERTY RIGHT, AND NO LICENSE TO ANY THIRD PARTY TECHNOLOGY OR INTELLECTUAL PROPERTY RIGHT, IS GRANTED HEREIN. SENSATA DATA SHEETS ARE PROVIDED "AS IS". SENSATA MAKES NO WARRANTIES OR REPRESENTATIONS WITH REGARD TO THE DATA SHEETS OR USE OF THE DATA SHEETS, EXPRESS, IMPLIED OR STATUTORY, INCLUDING ACCURACY OR COMPLETENESS. SENSATA DISCLAIMS ANY WARRANTY OF TITLE AND ANY IMPLIED WARRANTIES OF MERCHANTABILITY, FITNESS FOR A PARTICULAR PURPOSE, QUIET ENJOYMENT, QUIET POSSESSION, AND NON-INFRINGEMENT OF ANY THIRD PARTY INTELLECTUAL PROPERTY RIGHTS WITH REGARD TO SENSATA DATA SHEETS OR USE THEREOF.

All products are sold subject to Sensata's terms and conditions of sale supplied at www.sensata.com SENSATA ASSUMES NO LIABILITY FOR APPLICATIONS ASSISTANCE OR THE DESIGN OF BUYERS' PRODUCTS. BUYER ACKNOWLEDGES AND AGREES THAT IT IS SOLELY RESPONSIBLE FOR COMPLIANCE WITH ALL LEGAL, REGULATORY AND SAFETY-RELATED REQUIREMENTS CONCERNING ITS PRODUCTS, AND ANY USE OF SENSATA COMPONENTS IN ITS APPLICATIONS, NOTWITHSTANDING ANY APPLICATIONS-RELATED INFORMATION OR SUPPORT THAT MAY BE PROVIDED BY SENSATA.

Mailing Address: Sensata Technologies, Inc., 529 Pleasant Street, Attleboro, MA 02703, USA.

CONTACT US

Americas

+1 (877) 502 5500 – Option 2
sales.crydom@sensata.com

Europe, Middle East & Africa

+44 (1202) 416170
ssr-info.eu@sensata.com

Asia Pacific

sales.isasia@list.sensata.com
 China +86 (21) 2306 1500
 Japan +81 (45) 277 7117
 Korea +82 (31) 601 2004
 India +91 (80) 67920890
 Rest of Asia +886 (2) 27602006
 ext 2808