

- ① HOUSING: NYLON OR POLYESTER, FLAME RETARDANT 94V-0 RATED, GLASS FILLED, BLACK.
SHELLS: CARBON STEEL.
CONTACTS: BRASS.
BOARDLOCKS: COPPER ALLOY.
EYELETS: BRASS.
- ② SHELLS: 2.54μm[.000100] MIN TIN OVER 1.27μm[.000050] MIN COPPER.
EYELETS: 5.08μm[.000200] MIN TIN OVER COPPER FLASH.
CONTACTS AND BOARDLOCKS: SEE TABLE.
INSERTS AND BOARDLOCKS: CLEAR CHROMATE.
- ③ GOLD FLASH ON THE MATING SURFACES, 2.54μm[.000100] MIN TIN OR TIN-LEAD PLATE ON THE SOLDER END, 1.27μm[.000050] MIN NICKEL UNDERPLATE ON THE ENTIRE CONTACT.
- ④ 0.76μm[.000030] MIN GOLD PLATE ON THE MATING SURFACES, 2.54μm[.000100] MIN TIN OR TIN-LEAD PLATE ON THE SOLDER END, 1.27μm[.000050] MIN NICKEL UNDERPLATE ON THE ENTIRE CONTACT
-OR-
GOLD FLASH OVER PALLADIUM-NICKEL PLATE, 0.76μm[.000030] MIN TOTAL ON THE MATING SURFACES, 2.54μm[.000100] MIN TIN OR TIN-LEAD PLATE ON THE SOLDER END, 1.27μm[.000050] MIN NICKEL UNDERPLATE ON THE ENTIRE CONTACT.
- ⑤ 5.08μm[.000200] MIN TIN-LEAD OVER 1.27μm[.000050] MIN NICKEL.
- ⑥ 5.08μm[.000200] MIN TIN OVER 1.27μm[.000050] MIN NICKEL.
- ⑦ DIMENSION APPLIES FROM CENTER OF CONTACTS.
- ⑧ OBSOLETE PARTS: OBSOLETE CIS STREAMLINING PER D.RENAUD/D.SINISI

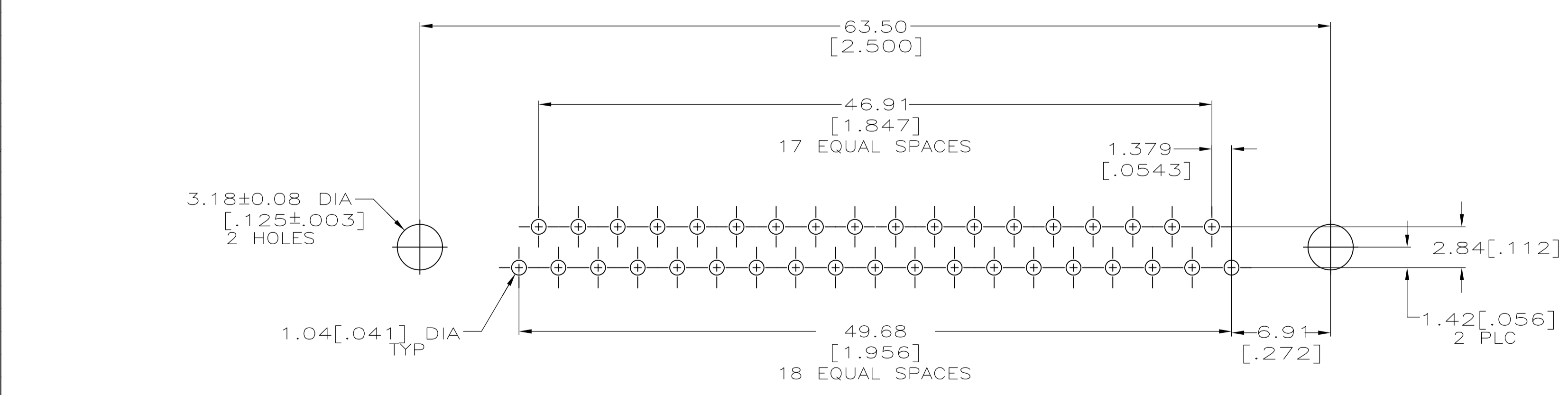
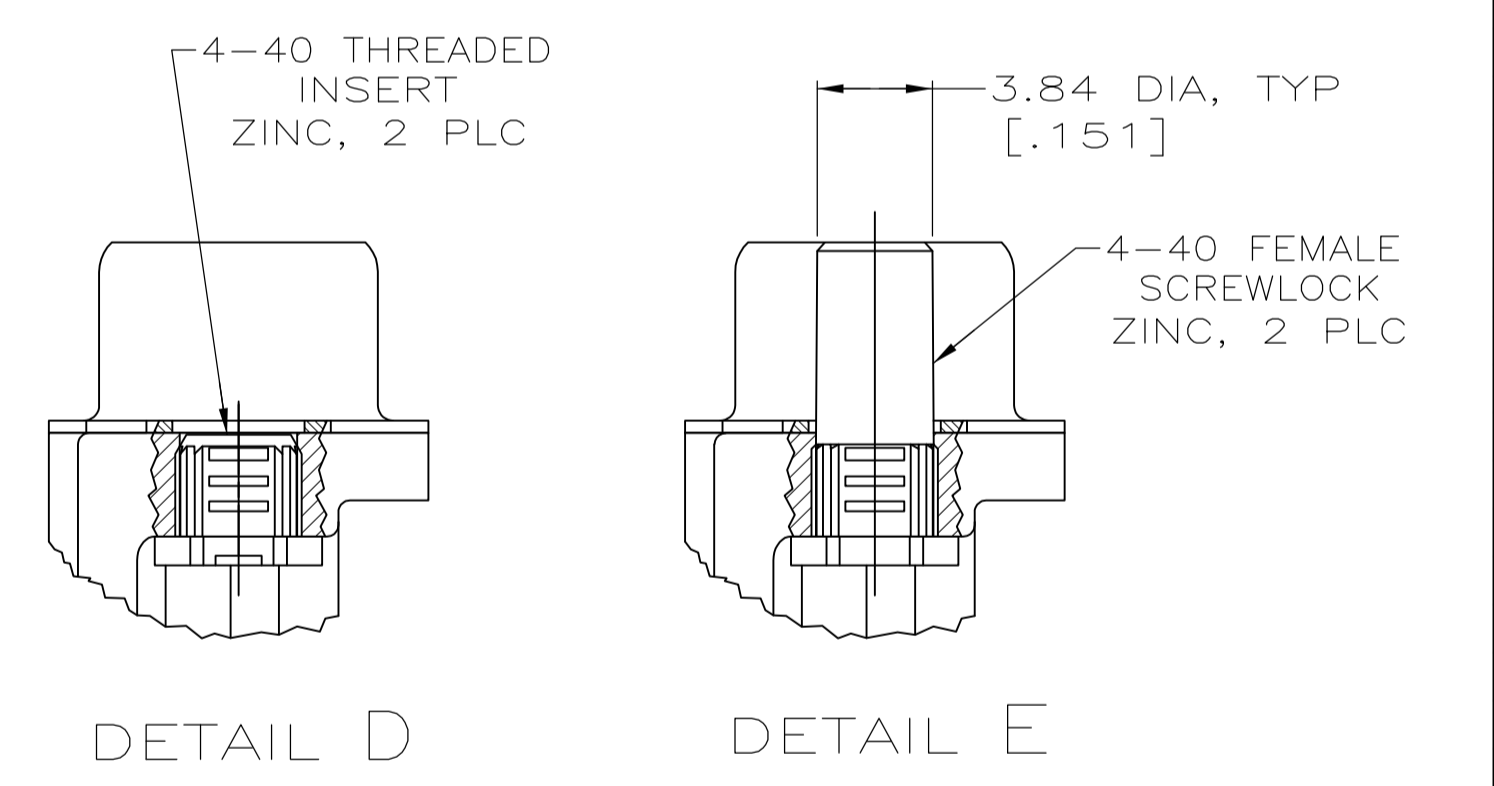
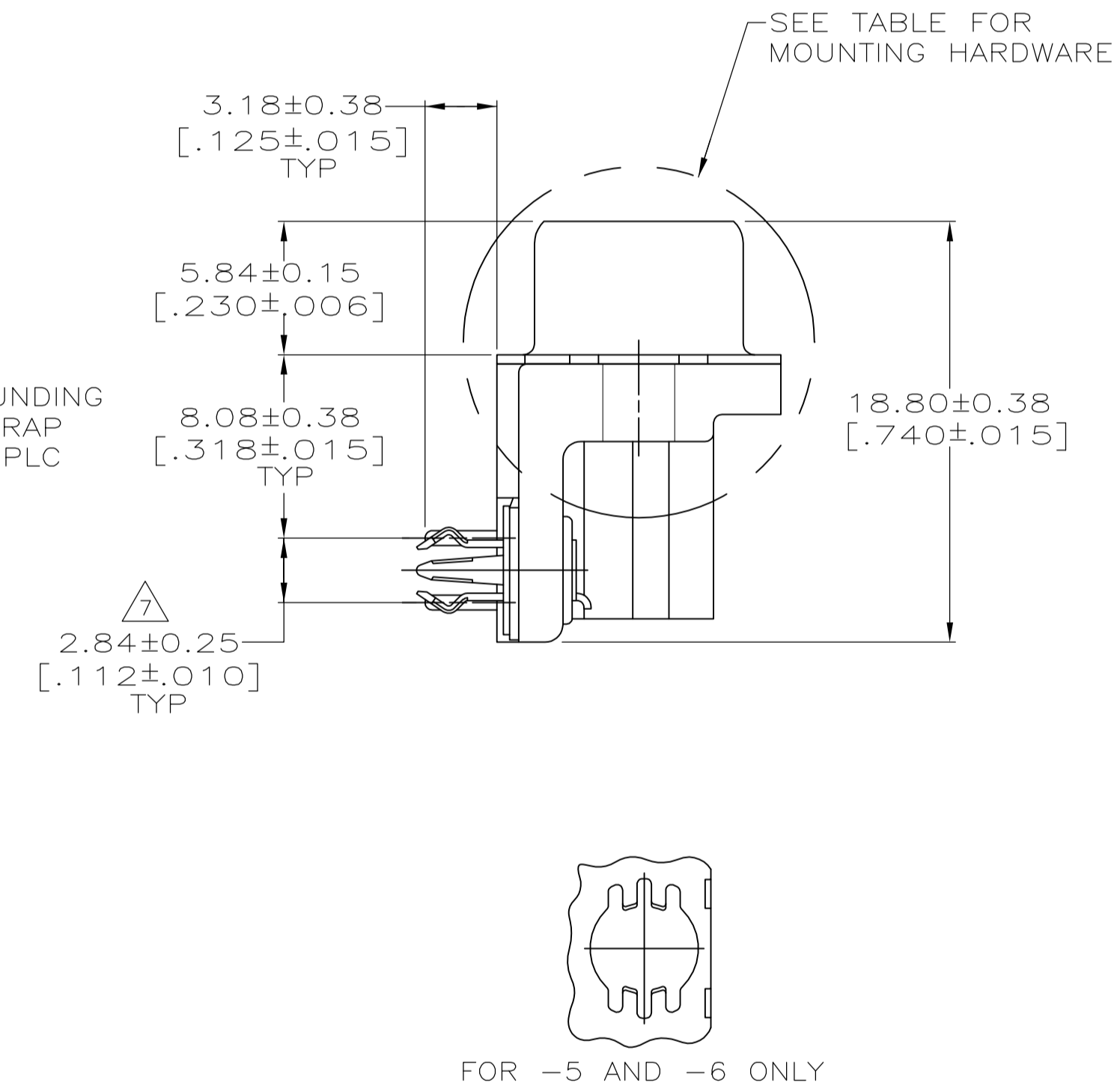
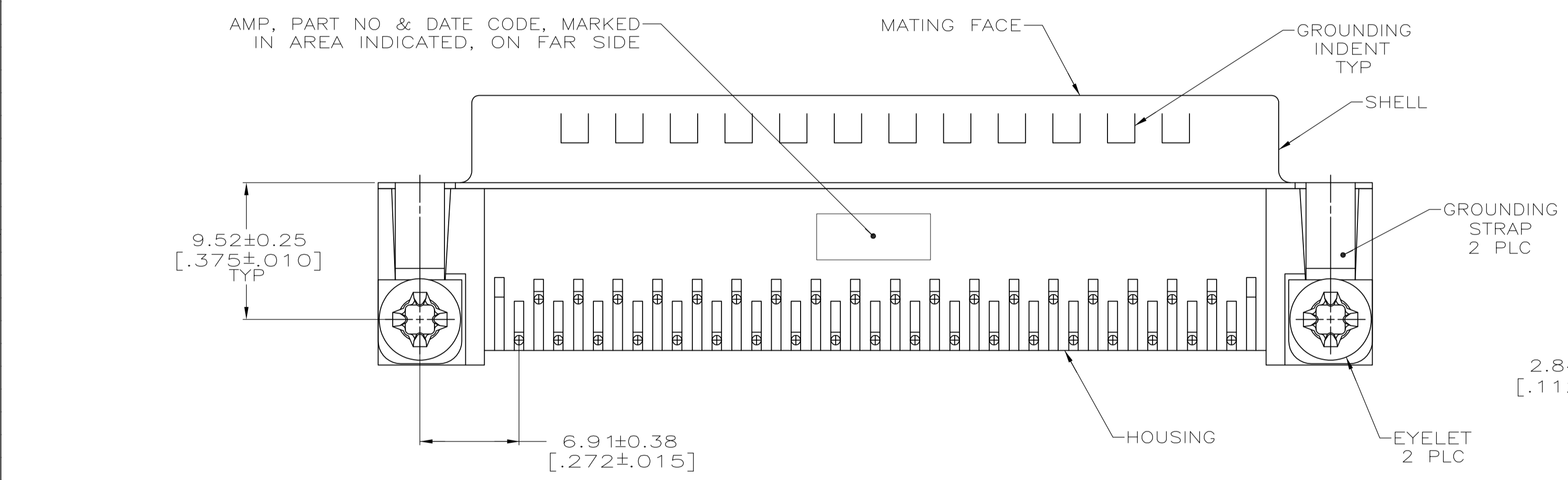

RECOMMENDED P.C. BOARD MOUNTING DIMENSIONS
P.C. BOARD THICKNESS: 1.57[.062]

⑧ OBSOLETE	SEE DETAIL E	⑥	④	-6-747843-9
	SEE DETAIL D	⑥	④	-6-747843-8
	-	⑥	④	6-747843-7
	SEE DETAIL E	⑤	④	747843-6
OBSOLETE	SEE DETAIL E	⑤	③	747843-5
	SEE DETAIL D	⑤	④	747843-4
	SEE DETAIL D	⑤	③	747843-3
OBSOLETE	-	⑤	④	747843-2
OBSOLETE	-	⑤	③	747843-1
	MOUNTING HARDWARE	BOARDLOCK FINISH	CONTACT FINISH	PART NUMBER

THIS DRAWING IS A CONTROLLED DOCUMENT. DIMENSIONING AND TOLERANCING PER ASME Y14.5M-2009.

DIMENSIONS: mm [INCHES]	TOLERANCES UNLESS OTHERWISE SPECIFIED:	APPROVED: M.D. GALLOWAY	DATE: 06-FEB-90	NAME:
0 PLC ± -	1 PLC ± -	PRODUCT SPEC: 108-40025	DATE: 05-FEB-90	W.G. LENKER
2 PLC ± -	3 PLC ± 0.13[.005]	APPLICATION SPEC: 114-40010	DATE: 05-FEB-90	R. STONE
4 PLC ± -	ANGLES ± ° 0'	SIZE: A1	SCALE: 4:1	M.D. GALLOWAY

RIGHT ANGLE, FRONT METAL SHELL, .318 SERIES, BOARDLOCKS, AMPLIMITE® HD-20

WEIGHT: -

CUSTOMER DRAWING

SCALE: 4:1 SHEET 1 OF 1 REV U