

4

3

2

1

THIS DRAWING IS UNPUBLISHED. RELEASED FOR PUBLICATION
 © COPYRIGHT - BY TYCO ELECTRONICS CORPORATION. ALL RIGHTS RESERVED.

LOC	DIST	REVISIONS					
AF	50	P	LTR	DESCRIPTION	DATE	DWN	APVD
			A3	REVISED PER ECR-06-022030	21SEP06	HMR	DD

- 1 CONTINUOUS STRIP ON REELS.
- 2 CRIMP WIDTH: .160 F TYPE.
 CRIMP HEIGHT ($\pm .002$) = (TOTAL CMA + 25,181) / 272,727
 GENERAL APPLICATOR GUIDELINES MUST BE FOLLOWED
 AS SPECIFIED IN CATALOG # 82221.

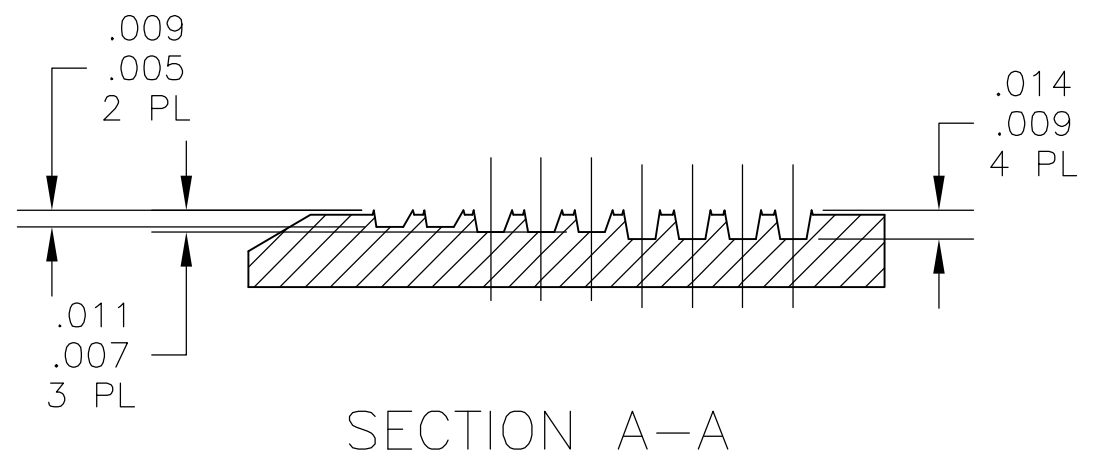
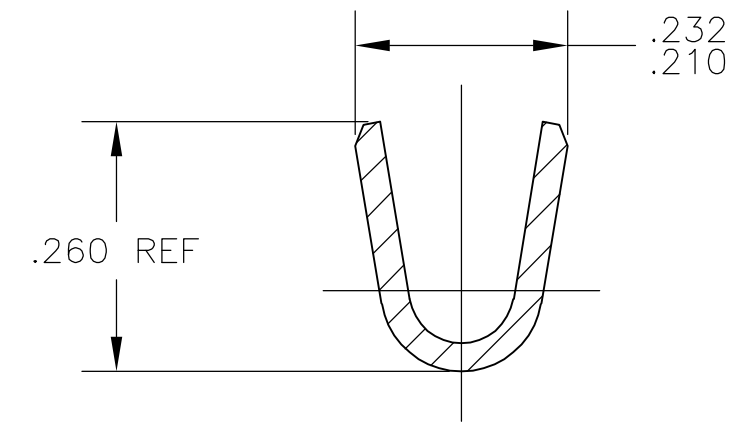
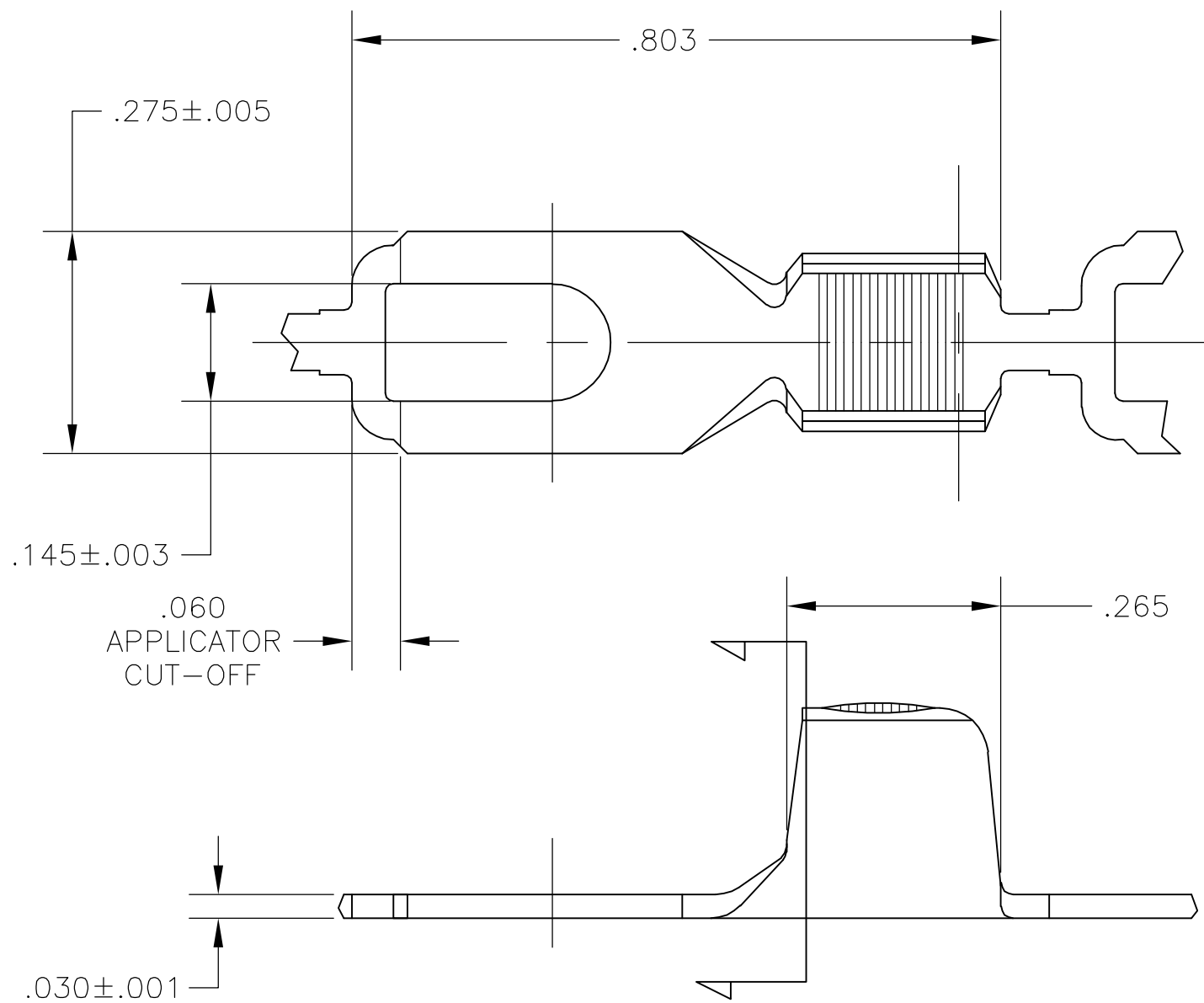

THIS DRAWING IS A CONTROLLED DOCUMENT.		DWN	JR RUTH	15SEP05
DIMENSIONS: INCHES		CHK	D.F. DECKER	15SEP05
		APVD	D.F. DECKER	15SEP05
		PRODUCT SPEC		
MATERIAL		APPLICATION SPEC		
082 BRASS		WEIGHT -		
FINISH		RESTRICTED TO		
.000150 MIN TIN		-		

7000-13000		1742348-1	
WIRE RANGE		PART NUMBER	
Tyco Electronics Corporation Harrisburg, PA 17105-3608			
NAME			
SPADE, AMPLIVAR, 9 SERRATIONS, 6 STUD SIZE			
SIZE	CAGE CODE	DRAWING NO	RESTRICTED TO
A3	00779	C-1742348	-
CUSTOMER DRAWING		SCALE	SHEET
		5:1	1 OF 1
		REV	A3