

2xØ3.10±0.12x11.18 DP
 RECOMMENDED SCREW: 6-19 [M3.63 x 1.34]
 THREAD-FORMING SCREW,
 TORQUE: 11-15 IN-LB [1.24-1.70 NM]

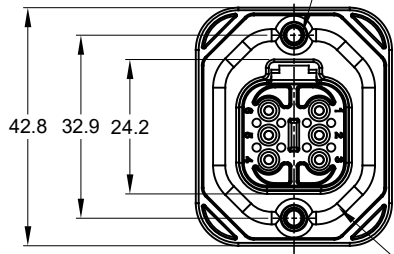

FLANGE SEAL

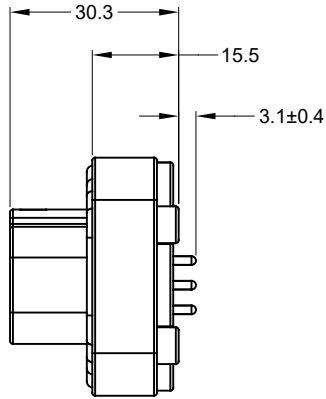

4xØ2.79±0.12 x8.0 DP
 RECOMMENDED SCREW: 4-20 [M3.12 x 1.27]
 THREAD-FORMING SCREW,
 TORQUE: 6-10 IN-LB [0.68-1.13 NM]

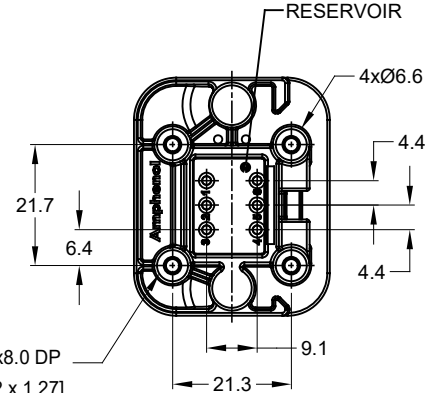

RESERVOIR

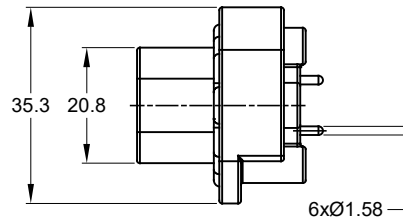
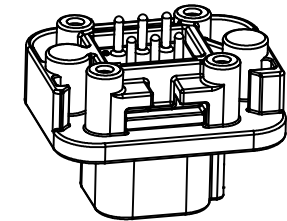

NOTES: UNLESS OTHERWISE SPECIFIED

1. MATERIAL:
 HOUSING: THERMOPLASTIC
 SEAL: SILICONE RUBBER
 CONTACT: COPPER ALLOY
2. MODIFICATIONS: FLANGE, PCB MOUNT STRAIGHT
3. SPECIFICATIONS:
 - 3.1 CURRENT RATING: 13 AMPS
 - 3.2 OPERATING TEMPERATURE: -55°C TO +125°C
 - 3.3 DIELECTRIC WITHSTANDING VOLTAGE: LESS THAN 2 MILLIAMPS CURRENT LEAKAGE @ 1500 VOLTS AC.
 - 3.4 INSULATION RESISTANCE: 1000 MEGOHMS MIN @ 25°C.
 - 3.5 MOISTURE RESISTANCE: IP67 (MATED CONDITION)
 - 3.6 MATING CYCLE DURABILITY: 100 CYCLES
 - 3.7 RoHS COMPLIANT
4. MATING PART: AT06-6S* PLUG (* = MODIFICATIONS)
5. ALL DIMENSIONS ARE FOR REFERENCE USE ONLY.
6. POTTED CONNECTORS SPECIFIED FOR UP TO 5 P.S.I. APPLICATIONS.

REVISIONS					
REV	ECO	DESCRIPTION	DATE	BY	APPR
01	--	RELEASE NEW DRAWING	2MAR18	JONY	TOMMY
A2	--	REVISED DRAWING	10JUL20	JHEAD	DH

TITLE: PCB MOUNT RECEPTACLE 6 PIN STRAIGHT AT SERIES
 DWG NO: AT15-6PX-BMXX
 REV: A2
 SH: 1
 OF: 2

AT15-6PX-BMXX		REF: DT15-6P, DT15-6P-G003, DT15-6P-GP01	
PART NUMBER		DESCRIPTION	
QUANTITY	MATERIALS LIST		
UNLESS OTHERWISE SPECIFIED 1) All dimensions are in metric(mm). 2) Tolerances are as follows: 1 PL DEC ±0.30 2 PL DEC ±0.15 3 PL DEC ±0.08 Fractions ±1/64 Angles ±1° 3) Note reference =		SIGNATURES DRAWN: JONY XIE 2MAR18 CHECKED: ORION LI 2MAR18 ENGINEER: APPROVAL: TOMMY XIE 2MAR18	
MATERIAL SPECIFICATIONS:		DATE	
PROCESS SPECIFICATIONS:		CUSTOMER:	
NEXT ASSY:		THIS DRAWING IS SUPPLIED FOR INFORMATION ONLY. DESIGN FEATURES, SPECIFICATIONS AND PERFORMANCE DATA SHOWN HEREON ARE THE PROPERTY OF THE AMPHENOL CORPORATION. NO RIGHTS OF REPRODUCTION ARE IMPLIED. ALL DIMENSIONS ARE SUBJECT TO NORMAL MANUFACTURING VARIATIONS.	
		 Sine Systems - www.amphenol-sine.com 44724 Morley Drive Clinton Township, MI 48036 BOARDLOCK PCB MOUNT RECEPTACLE, 6 PIN, STRAIGHT, AT SERIES	
		SIZE: B C-	TYPE: AT15-6PX-BMXX
		SCALE: NONE	REVISION: A2
		SHEET 1 OF 2	

REVISIONS					
REV	ECO	DESCRIPTION	DATE	BY	APPR
01	--	RELEASE NEW DRAWING	2MAR18	JONY	TOMMY
A2	--	REVISED DRAWING	10JUL20	JHEAD	DH

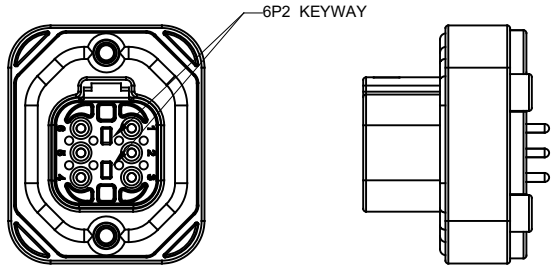
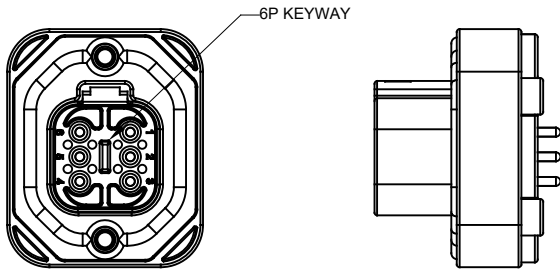

AT15-6P-BMXX VARIANTS		
CONTACT PLATING	POTTING OR NOT IN RESERVOIR	PART NUMBER
GOLD	NO POTTING	AT15-6P-BM01GRY
GOLD	POTTING	AT15-6P-BM02GRY
TIN	NO POTTING	AT15-6P-BM03GRY
TIN	POTTING	AT15-6P-BM04GRY

AT15-6P2-BMXX VARIANTS		
CONTACT PLATING	POTTING OR NOT IN RESERVOIR	PART NUMBER
GOLD	NO POTTING	AT15-6P2-BM01BLU
GOLD	POTTING	AT15-6P2-BM02BLU
TIN	NO POTTING	AT15-6P2-BM03BLU
TIN	POTTING	AT15-6P2-BM04BLU

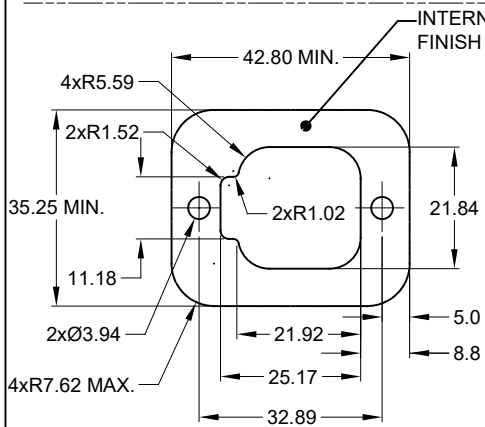

INTERNAL SEALING SURFACE
FINISH TO BE 3.2 OR BETTER $\sqrt{10.13}$

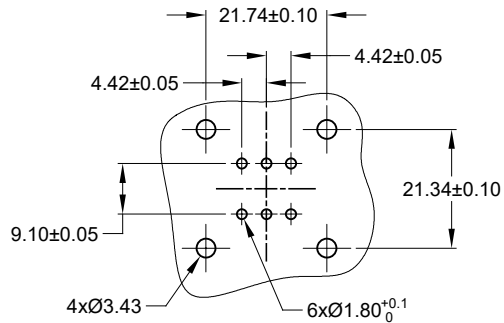

AT15-6PX-BMXX		DESCRIPTION		ITEM
QUANTITY	PART NUMBER			
MATERIALS LIST				
UNLESS OTHERWISE SPECIFIED: 1) All dimensions are in metric(mm). 2) Tolerances are as follows: 1 PL DEC ±0.30 Fractions ±1/64 2 PL DEC ±0.15 Angles ±1° 3 PL DEC ±0.08		SIGNATURES DATE DRAWN: JONY XIE 2MAR18 CHECKED: ORON LI 2MAR18 ENGINEER: APPROVAL: TOMMY XIE 2MAR18		
MATERIAL SPECIFICATIONS:		CUSTOMER: THIS DRAWING IS SUPPLIED FOR INFORMATION ONLY. DESIGN FEATURES, SPECIFICATIONS AND PERFORMANCE DATA SHOWN HEREON ARE THE PROPERTY OF THE AMPHENOL CORPORATION. NO RIGHTS OF REPRODUCTION ARE IMPLIED. ALL DIMENSIONS ARE SUBJECT TO NORMAL MANUFACTURING VARIATIONS.		
PROCESS SPECIFICATIONS:		SCALE: NONE		
NEXT ASSY:		SHEET 2 OF 2		
		Amphenol Sine Systems - www.amphenol-sine.com 44724 Morley Drive Clinton Township, MI 48036		
		BOARDLOCK PCB MOUNT RECEPTACLE, 6 PIN, STRAIGHT, AT SERIES		
		SIZE: B C-	DWG NO: AT15-6PX-BMXX	REVISION: A2

TITLE: PCB MOUNT RECEPTACLE 6PIN STRAIGHT AT SERIES DWG NO: AT15-6PX-BMXX REV: A2 SH: 2 OF: 2