

# XC74WL241ASR

ETR1324\_001

## CMOS Logic

### ■ GENERAL DESCRIPTION

XC74WL241ASR is dual bus buffer manufactured using silicon gate CMOS processes. The small supply current, which is one of the features of the CMOS logic, gives way to high speed operations which enables LS-TTL.

With wave forming buffers connected internally, stabilized output can be achieved as the series offers high noise immunity.

As the series is integrated into a mini molded, MSOP-8B package, high density mounting is possible.

### ■ APPLICATIONS

- Palmtops
- Digital equipment

### ■ FEATURES

**High Speed Operations** : tpd = 3.8ns (TYP.) (VCC=5V)

**Operating Voltage Range** : 2V ~ 5.5V

**Low Power Consumption** : 2  $\mu$  A (MAX.)@Ta=25°C

**CMOS Logic Dual Bus Buffer**

**(Non inverted 3-state outputs)**

**Small Package** : MSOP-8B

### ■ PIN CONFIGURATION

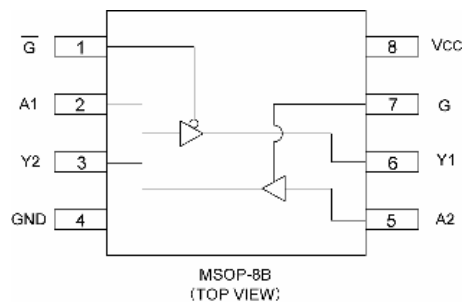

### ■ FUNCTIONS

INPUT			OUTPUT
$\bar{G}$	G	A	Y
L	H	H	H
L	H	L	L
H	L	X	Z

H=High level

L=Low level

X=Don't care

Z=High impedance

### ■ ABSOLUTE MAXIMUM RATINGS

Ta=-40°C~85°C

PARAMETER	SYMBOL	RATINGS	UNITS
Supply Voltage	VCC	-0.5~+6.0	V
Input Voltage	VIN	-0.5~+6.0	V
Output Voltage	VOUT	-0.5~VCC+0.5	V
Input Diode Current	I <sub>IK</sub>	-20	mA
Output Diode Current	I <sub>OK</sub>	±20	mA
Switch Output Current	I <sub>OUT</sub>	±25	mA
VCC,GND Current	I <sub>CC</sub> ,I <sub>GND</sub>	±50	mA
Power Dissipation (Ta = 25°C)	P <sub>d</sub>	300	mW
Storage Temperature Range	T <sub>stg</sub>	-65~+150	°C

Note : Voltage is all ground standardized.

## RECOMMENDED OPERATING CONDITIONS

PARAMETER	SYMBOL	CONDITIONS	UNITS
Supply Voltage	V <sub>CC</sub>	2~5.5	V
Input Voltage	V <sub>IN</sub>	0~5.5	V
Output Voltage	V <sub>OUT</sub>	0~V <sub>CC</sub>	V
Operating Temperature Range	T <sub>opr</sub>	-40~+85	°C
Input Rise and Fall Time	t <sub>r,tf</sub>	0~200 (V <sub>CC</sub> =3.3V)	ns
		0~100 (V <sub>CC</sub> =5V)	

## DC ELECTRICAL CHARACTERISTICS

PARAMETER	SYMBOL	V <sub>CC</sub> (V)	CONDITIONS	T <sub>a</sub> =25°C			T <sub>a</sub> =-40°C~85°C		UNITS	
				MIN.	TYP.	MAX.	MIN.	MAX.		
Input Voltage	V <sub>IH</sub>	2.0		1.50	—	—	1.50	—	V	
		3.0		2.10	—	—	2.10	—		
		5.5		3.85	—	—	3.85	—		
	V <sub>IL</sub>	2.0		—	—	0.50	—	0.50	V	
		3.0		—	—	0.90	—	0.90		
		5.5		—	—	1.65	—	1.65		
Output Voltage	V <sub>OH</sub>	2.0	V <sub>IN</sub> =V <sub>IH</sub>	I <sub>OH</sub> =-50 μA	1.90	2.00	—	1.90	—	V
		3.0			2.90	3.00	—	2.90	—	
		4.5		4.40	4.50	—	4.40	—		
		3.0		I <sub>OH</sub> =-4mA	2.58	—	—	2.48	—	
		4.5		I <sub>OH</sub> =-8mA	3.94	—	—	3.80	—	
	V <sub>OL</sub>	2.0	V <sub>IN</sub> =V <sub>IL</sub>	I <sub>OL</sub> =50 μA	—	—	0.10	—	0.10	V
		3.0			—	—	0.10	—	0.10	
		4.5		—	—	0.10	—	0.10		
		3.0		I <sub>OL</sub> =4mA	—	—	0.36	—	0.44	
		4.5		I <sub>OL</sub> =8mA	—	—	0.36	—	0.44	
3 State Off-Leak Current	I <sub>OZ</sub>	5.0	V <sub>IN</sub> =V <sub>IL</sub> or V <sub>IH</sub> , V <sub>OUT</sub> =V <sub>CC</sub> or GND	-0.25	—	0.25	-2.50	2.50	μA	
Input Current	I <sub>IN</sub>	0~5.5	V <sub>IN</sub> =V <sub>CC</sub> or GND	-0.10	—	0.10	-1.00	1.00	μA	
Static Supply Current	I <sub>CC</sub>	5.5	V <sub>IN</sub> =V <sub>CC</sub> or GND	—	—	2.00	—	20.0	μA	

## SWITCHING ELECTRICAL CHARACTERISTICS

(tr=tf=3ns)

PARAMETER	SYMBOL	CONDITIONS		Ta=25°C			Ta=-40°C~85°C		UNITS	
		CL	Vcc(V)	MIN.	TYP.	MAX.	MIN.	MAX.		
Delay Time	tPLH	15pF	3.3		—	5.6	8.0	1.0	9.5	ns
			5.0		—	3.8	5.5	1.0	6.5	
		50pF	3.3		—	8.1	11.5	1.0	13.0	ns
			5.0		—	5.3	7.5	1.0	8.5	
	tPHL	15pF	3.3		—	5.6	8.0	1.0	9.5	ns
			5.0		—	3.8	5.5	1.0	6.5	
		50pF	3.3		—	8.1	11.5	1.0	13.0	ns
			5.0		—	5.3	7.5	1.0	8.5	
Output Enable Time	tzL	15pF	3.3	RL=1kΩ	—	5.4	8.0	1.0	9.5	ns
			5.0		—	3.6	5.1	1.0	6.0	
		50pF	3.3		—	7.9	11.5	1.0	13.0	ns
			5.0		—	5.1	7.1	1.0	8.0	
	tzH	15pF	3.3	RL=1kΩ	—	5.4	8.0	1.0	9.5	ns
			5.0		—	3.6	5.1	1.0	6.0	
		50pF	3.3		—	7.9	11.5	1.0	13.0	ns
			5.0		—	5.1	7.1	1.0	8.0	
Output Disable Time	tLZ	50pF	3.3	RL=1kΩ	—	9.5	13.2	1.0	15.0	ns
			5.0		—	6.1	8.8	1.0	10.0	
	tHZ	50pF	3.3	RL=1kΩ	—	9.5	13.2	1.0	15.0	ns
			5.0		—	6.1	8.8	1.0	10.0	
Output Pin Skew (Note)	tosLH	50pF	3.3		—	—	1.5	—	1.5	ns
			5.0		—	—	1.0	—	1.0	
	tosHL	50pF	3.3		—	—	1.5	—	1.5	ns
			5.0		—	—	1.0	—	1.0	
Input Capacitance	CIN	—	—		—	4	10	—	10	pF
Output Capacitance	COU	—	—		—	6	—	—	—	pF
Power Dissipation Capacitance	Cpd	—	—		—	17	—	—	—	pF

Note: tosLH and tosHL are the guaranteed parameters.

$$\text{tosLH} = |t_{\text{PLHm}} - t_{\text{PHLn}}|, \text{tosHL} = |t_{\text{PHLm}} - t_{\text{PLLn}}|$$

## NOISE CHARACTERISTICS

(tr=tf=3ns)

PARAMETER	SYMBOL	CONDITIONS		Ta=25°C			UNITS	
		CL	Vcc(V)	MIN.	TYP.	MAX.		
Non Functional Output Maximum Dynamic VOL	VOLP	50pF	5.0		—	0.5	0.8	V
Non Functional Output Minimum Dynamic VOL	VOLV	50pF	5.0		-0.8	-0.5	—	V
Minimum Dynamic VIH	VIHD	50pF	5.0		—	—	3.5	V
Maximum Dynamic VIL	VILD	50pF	5.0		—	—	1.5	V

# XC74WL241ASR

## ■ DELAY TIME

### ● Test Circuit

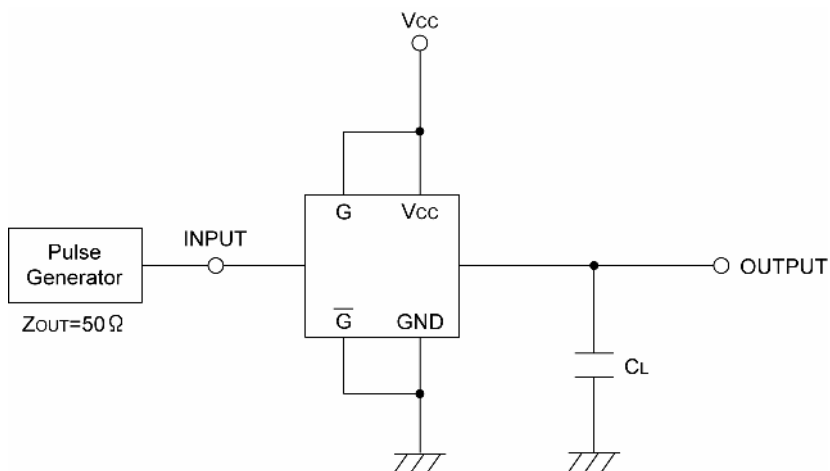

### ● Waveform

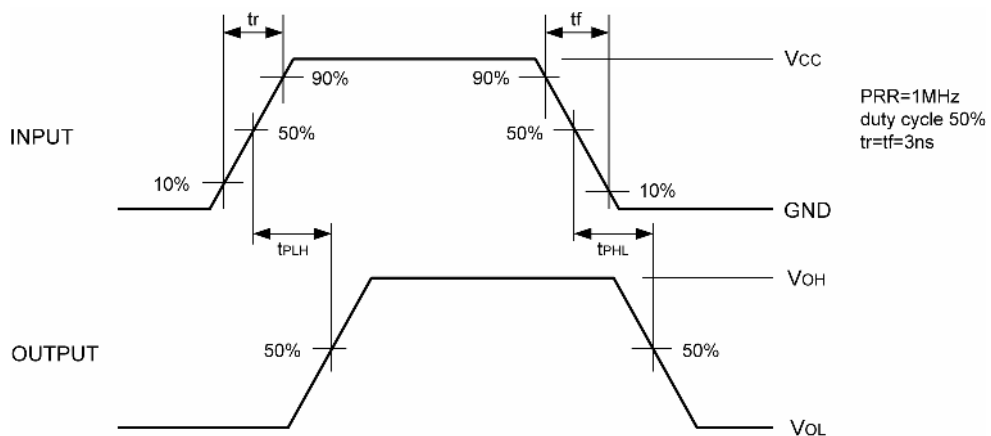

## OUTPUT ENABLE TIME, OUTPUT DISABLE TIME

### Test Circuit

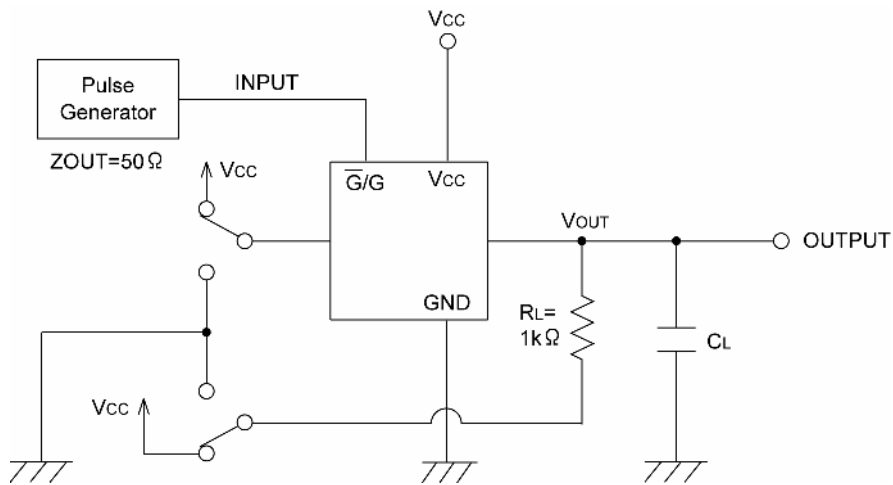

### Waveform

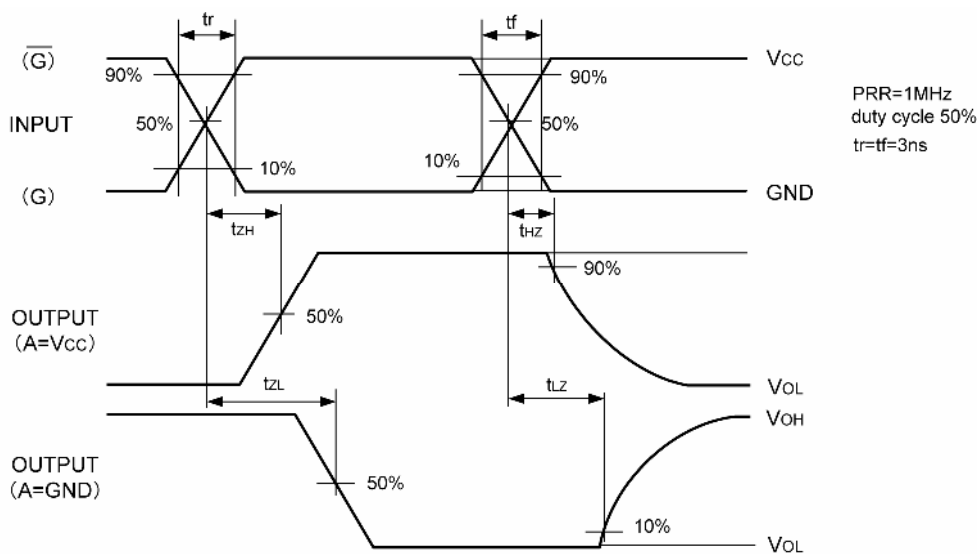

1. The products and product specifications contained herein are subject to change without notice to improve performance characteristics. Consult us, or our representatives before use, to confirm that the information in this catalog is up to date.
2. We assume no responsibility for any infringement of patents, patent rights, or other rights arising from the use of any information and circuitry in this catalog.
3. Please ensure suitable shipping controls (including fail-safe designs and aging protection) are in force for equipment employing products listed in this catalog.
4. The products in this catalog are not developed, designed, or approved for use with such equipment whose failure of malfunction can be reasonably expected to directly endanger the life of, or cause significant injury to, the user.  
(e.g. Atomic energy; aerospace; transport; combustion and associated safety equipment thereof.)
5. Please use the products listed in this catalog within the specified ranges.  
Should you wish to use the products under conditions exceeding the specifications, please consult us or our representatives.
6. We assume no responsibility for damage or loss due to abnormal use.
7. All rights reserved. No part of this catalog may be copied or reproduced without the prior permission of Torex Semiconductor Ltd.

**TOREX SEMICONDUCTOR LTD.**