

LM5025A Active Clamp Voltage Mode PWM Controller

1 Features

- Internal Start-Up Bias Regulator
- 3-A Compound Main Gate Driver
- Programmable Line Undervoltage Lockout (UVLO) With Adjustable Hysteresis
- Voltage Mode Control With Feedforward
- Adjustable Dual Mode Overcurrent Protection
- Programmable Overlap or Dead Time Between the Main and Active Clamp Outputs
- Volt × Second Clamp
- Programmable Soft Start
- Leading Edge Blanking
- Single Resistor Programmable Oscillator
- Oscillator UP and DOWN Sync Capability
- Precision 5-V Reference
- Thermal Shutdown
- Packages:
 - 16-Pin TSSOP
 - Thermally Enhanced 16-Pin WSON (5 mm × 5 mm)

2 Applications

- Server Power Supplies
- 48-V Telecom Power Supplies
- 42-V Automotive Applications
- High-Efficiency DC-to-DC Power Supplies

3 Description

The LM5025A is a functional variant of the LM5025 active clamp PWM controller. The functional differences of the LM5025A are that the CS1 and CS2 current limit thresholds have been increased to 0.5 V, the internal CS2 filter discharge device has been disabled and no longer operates each clock cycle, and the internal V_{CC} and V_{REF} regulators continue to operate when the line UVLO pin is below threshold.

The LM5025A PWM controller contains all of the features necessary to implement power converters using the Active Clamp / Reset technique. With the active clamp technique, higher efficiencies and greater power densities can be realized compared to conventional catch winding or RDC clamp / reset techniques. Two control outputs are provided: the main power switch control (OUT_A) and the active clamp switch control (OUT_B). The two internal compound gate drivers parallel both MOS and bipolar devices, providing superior gate drive characteristics. This controller is designed for high-speed operation including an oscillator frequency range up to 1 MHz and total PWM and current sense propagation delays less than 100 ns. The LM5025A includes a high-voltage start-up regulator that operates over a wide input range of 13 V to 90 V. Additional features include: line undervoltage lockout (UVLO), soft start, oscillator UP and DOWN sync capability, precision reference, and thermal shutdown.

Device Information⁽¹⁾

| PART NUMBER | PACKAGE | BODY SIZE (NOM) |
|-------------|------------|-------------------|
| LM5025A | TSSOP (16) | 5.00 mm × 4.40 mm |
| | WSON (16) | 5.00 mm × 5.00 mm |

(1) For all available packages, see the orderable addendum at the end of the data sheet.

Simplified Active Clamp Forward Power Converter

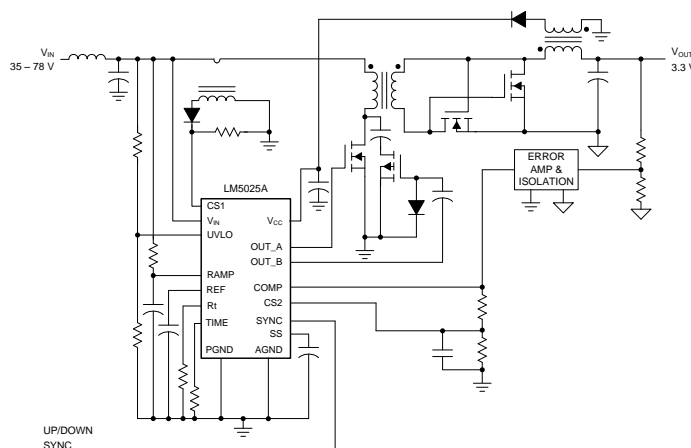

Copyright © 2016, Texas Instruments Incorporated



Table of Contents

| | | | | | |
|----------|--|-----------|-----------|---|-----------|
| 1 | Features | 1 | 8 | Application and Implementation | 18 |
| 2 | Applications | 1 | 8.1 | Application Information..... | 18 |
| 3 | Description | 1 | 8.2 | Typical Application | 18 |
| 4 | Revision History | 2 | 8.3 | System Example | 23 |
| 5 | Pin Configuration and Functions | 3 | 9 | Power Supply Recommendations | 23 |
| 6 | Specifications | 5 | 10 | Layout | 23 |
| 6.1 | Absolute Maximum Ratings | 5 | 10.1 | Layout Guidelines | 23 |
| 6.2 | ESD Ratings..... | 5 | 10.2 | Layout Example | 24 |
| 6.3 | Recommended Operating Conditions | 5 | 10.3 | Thermal Protection..... | 24 |
| 6.4 | Thermal Information | 5 | 11 | Device and Documentation Support | 25 |
| 6.5 | Electrical Characteristics..... | 6 | 11.1 | Documentation Support | 25 |
| 6.6 | Typical Characteristics | 9 | 11.2 | Receiving Notification of Documentation Updates | 25 |
| 7 | Detailed Description | 11 | 11.3 | Community Resources..... | 25 |
| 7.1 | Overview | 11 | 11.4 | Trademarks | 25 |
| 7.2 | Functional Block Diagram | 12 | 11.5 | Electrostatic Discharge Caution..... | 25 |
| 7.3 | Feature Description..... | 13 | 11.6 | Glossary | 25 |
| 7.4 | Device Functional Modes..... | 17 | 12 | Mechanical, Packaging, and Orderable Information | 25 |

4 Revision History

NOTE: Page numbers for previous revisions may differ from page numbers in the current version.

| Changes from Revision E (March 2013) to Revision F | Page |
|--|-------------|
| • Added <i>ESD Ratings</i> table, <i>Feature Description</i> section, <i>Device Functional Modes</i> , <i>Application and Implementation</i> section, <i>Power Supply Recommendations</i> section, <i>Layout</i> section, <i>Device and Documentation Support</i> section, and <i>Mechanical, Packaging, and Orderable Information</i> section | 1 |
| • Changed <i>Thermal Information</i> table | 5 |
| • Deleted the THERMAL RESISTANCE row from <i>Electrical Characteristics</i> | 8 |

| Changes from Revision D (March 2013) to Revision E | Page |
|--|-------------|
| • Changed layout of National Semiconductor Data Sheet to TI format | 18 |

5 Pin Configuration and Functions

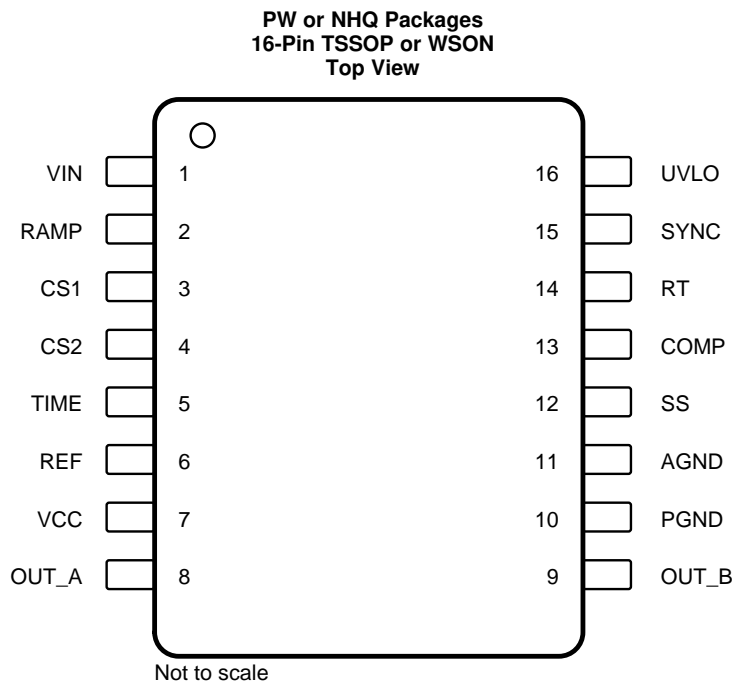

Pin Functions

| PIN | | I/O | DESCRIPTION | APPLICATION INFORMATION |
|-----|-----------------|-----|--|---|
| NO. | NAME | | | |
| 1 | V _{IN} | I | Source input voltage | Input to start-up regulator. Input range 13 V to 90 V, with transient capability to 105 V. |
| 2 | RAMP | I | Modulator ramp signal | An external RC circuit from Vin sets the ramp slope. This pin is discharged at the conclusion of every cycle by an internal FET, initiated by either the internal clock or the V × Sec Clamp comparator. |
| 3 | CS1 | I | Current sense input for cycle-by-cycle limiting | If CS1 exceeds 0.5 V the outputs goes into Cycle-by-Cycle current limit. CS1 is held low for 50 ns after OUT_A switches high providing leading edge blanking. |
| 4 | CS2 | I | Current sense input for soft restart | If CS2 exceeds 0.5 V, the outputs will be disabled and a soft start commenced. The soft-start capacitor will be fully discharged and then released with a pullup current of 1 μA. After the first output pulse (when SS = 1 V), the SS charge current will revert back to 20 μA. |
| 5 | TIME | I | Output overlap and dead-time control | An external resistor (R _{SET}) sets either the overlap time or dead time for the active clamp output. An R _{SET} resistor connected between TIME and GND produces in-phase OUT_A and OUT_B pulses with overlap. An R _{SET} resistor connected between TIME and REF produces out-of-phase OUT_A and OUT_B pulses with dead time. |
| 6 | REF | O | Precision 5-V reference output | Maximum output current: 10-mA locally decouple with a 0.1-μF capacitor. Reference stays low until the V _{CC} UV comparator is satisfied. |
| 7 | V _{CC} | P | Output from the internal high voltage start-up regulator. The V _{CC} voltage is regulated to 7.6 V. | If an auxiliary winding raises the voltage on this pin above the regulation setpoint, the internal start-up regulator shuts down, reducing the IC power dissipation. |
| 8 | OUT_A | O | Main output driver | Output of the main switch PWM output gate driver. Output capability of 3-A peak sink current. |

Pin Functions (continued)

| PIN | | I/O | DESCRIPTION | APPLICATION INFORMATION |
|-----|-------|-----|---|--|
| NO. | NAME | | | |
| 9 | OUT_B | O | Active Clamp output driver | Output of the Active Clamp switch gate driver. Capable of 1.25-A peak sink current. |
| 10 | PGND | G | Power ground | Connect directly to analog ground. |
| 11 | AGND | G | Analog ground | Connect directly to power ground. For the WSON package option, the exposed pad is electrically connected to AGND. |
| 12 | SS | I | Soft-start control | An external capacitor and an internal 20- μ A current source set the soft-start ramp. The SS current source is reduced to 1 μ A initially following a CS2 overcurrent event or an overtemperature event. |
| 13 | COMP | I | Input to the Pulse Width Modulator | An internal 5-k Ω resistor pullup is provided on this pin. The external opto-coupler sinks current from COMP to control the PWM duty cycle. |
| 14 | RT | I | Oscillator timing resistor pin | An external resistor connected from RT to ground sets the internal oscillator frequency. |
| 15 | SYNC | I | Oscillator UP and DOWN synchronization input | The internal oscillator can be synchronized to an external clock with a frequency 20% lower than the internal oscillator's free running frequency. There is no constraint on the maximum sync frequency. |
| 16 | UVLO | I | Line undervoltage shutdown | An external voltage divider from the power source sets the shutdown comparator levels. The comparator threshold is 2.5 V. Hysteresis is set by an internal current source (20 μ A) that is switched ON or OFF as the UVLO pin potential crosses the 2.5-V threshold. |
| — | EP | G | Exposed pad, underside of the WSON package option | Internally bonded to the die substrate. Connect to GND potential for low thermal impedance. |

6 Specifications

6.1 Absolute Maximum Ratings

over operating free-air temperature range (unless otherwise noted)⁽¹⁾⁽²⁾

| | MIN | MAX | UNIT |
|---------------------------------------|------|-----|------|
| V _{IN} to GND | –0.3 | 105 | V |
| V _{CC} to GND | –0.3 | 16 | V |
| CS1, CS2 to GND | –0.3 | 1 | V |
| All other inputs to GND | –0.3 | 7 | V |
| Junction temperature, T _J | | 150 | °C |
| Storage temperature, T _{stg} | –55 | 150 | °C |

- (1) Stresses beyond those listed under *Absolute Maximum Ratings* may cause permanent damage to the device. These are stress ratings only, which do not imply functional operation of the device at these or any other conditions beyond those indicated under *Recommended Operating Conditions*. Exposure to absolute-maximum-rated conditions for extended periods may affect device reliability.
- (2) If Military/Aerospace specified devices are required, please contact the TI Sales Office/ Distributors for availability and specifications.

6.2 ESD Ratings

| | | VALUE | UNIT |
|--------------------|---|-------|------|
| V _(ESD) | Electrostatic discharge Human-body model (HBM) ⁽¹⁾ | ±2000 | V |

- (1) JEDEC document JEP155 states that 500-V HBM allows safe manufacturing with a standard ESD control process.

6.3 Recommended Operating Conditions

over operating free-air temperature range (unless otherwise noted)

| | MIN | MAX | UNIT |
|---|-----|-----|------|
| V _{IN} voltage | 13 | 90 | V |
| External voltage applied to V _{CC} | 8 | 15 | V |
| Operating junction temperature | –40 | 125 | °C |

6.4 Thermal Information

| THERMAL METRIC ⁽¹⁾ | | LM5025A | | UNIT |
|-------------------------------|--|------------|------------|------|
| | | PW (TSSOP) | NHQ (WSON) | |
| | | 16 PINS | 16 PINS | |
| R _{θJA} | Junction-to-ambient thermal resistance | 98.7 | 30 | °C/W |
| R _{θJC(top)} | Junction-to-case (top) thermal resistance | 27.8 | 25.9 | °C/W |
| R _{θJB} | Junction-to-board thermal resistance | 44.3 | 9.3 | °C/W |
| Ψ _{JT} | Junction-to-top characterization parameter | 1.2 | 0.2 | °C/W |
| Ψ _{JB} | Junction-to-board characterization parameter | 43.6 | 9.5 | °C/W |
| R _{θJC(bot)} | Junction-to-case (bottom) thermal resistance | — | 2.3 | °C/W |

- (1) For more information about traditional and new thermal metrics, see the [Semiconductor and IC Package Thermal Metrics](#) application report.

6.5 Electrical Characteristics

Typical limits are for $T_J = 25^\circ\text{C}$, and minimum and maximum limits apply over the operating junction temperature range (-40°C to 125°C). $V_{IN} = 48\text{ V}$, $V_{CC} = 10\text{ V}$, $R_T = 31.3\text{ k}\Omega$, $R_{SET} = 27.4\text{ k}\Omega$ unless otherwise stated ⁽¹⁾

| PARAMETER | | TEST CONDITIONS | | MIN | TYP | MAX | UNIT |
|-----------------------------------|---|---|-------------------------------|------|--------------------------|------|---------------|
| START-UP REGULATOR | | | | | | | |
| V_{CC} Reg | V_{CC} regulation | No load | $T_J = 25^\circ\text{C}$ | | 7.6 | | V |
| | | | $T_J = T_{low}$ to T_{high} | 7.3 | | 7.9 | |
| | V_{CC} current limit | See ⁽²⁾ | $T_J = 25^\circ\text{C}$ | | 25 | | mA |
| | | | $T_J = T_{low}$ to T_{high} | 20 | | | |
| $I-V_{IN}$ | Start-up regulator leakage (external V_{CC} Supply) | $V_{IN} = 100\text{ V}$ | $T_J = 25^\circ\text{C}$ | | 165 | | μA |
| | | | $T_J = T_{low}$ to T_{high} | | | 500 | |
| V_{CC} SUPPLY | | | | | | | |
| | V_{CC} undervoltage lockout voltage (positive going V_{CC}) | $T_J = 25^\circ\text{C}$ | | | V_{CC} Reg - 120 mV | | V |
| | | $T_J = T_{low}$ to T_{high} | | | V_{CC} Reg - 220 mV | | |
| | V_{CC} undervoltage hysteresis | $T_J = 25^\circ\text{C}$ | | | 1.5 | | V |
| | | $T_J = T_{low}$ to T_{high} | | 1 | 2 | | |
| | V_{CC} supply current (I_{CC}) | $C_{gate} = 0$ | $T_J = T_{low}$ to T_{high} | | | 4.2 | mA |
| REFERENCE SUPPLY | | | | | | | |
| V_{REF} | Ref voltage | $I_{REF} = 0\text{ mA}$ | $T_J = 25^\circ\text{C}$ | | 5 | | V |
| | | | $T_J = T_{low}$ to T_{high} | 4.85 | | 5.15 | |
| | Ref voltage regulation | $I_{REF} = 0$ to 10mA | $T_J = 25^\circ\text{C}$ | | 25 | | mV |
| | | | $T_J = T_{low}$ to T_{high} | | 50 | | |
| Ref current limit | $T_J = 25^\circ\text{C}$ | | | 20 | | mA | |
| | $T_J = T_{low}$ to T_{high} | | 10 | | | | |
| CURRENT LIMIT | | | | | | | |
| $CS1$ Prop | $CS1$ delay to output | $CS1$ Step from 0 to 0.6 V, Time to onset of OUT Transition (90%), $C_{gate} = 0$ | | | 40 | | ns |
| $CS2$ Prop | $CS2$ delay to output | $CS2$ Step from 0 to 0.6 V, Time to onset of OUT Transition (90%), $C_{gate} = 0$ | | | 50 | | ns |
| | Cycle by cycle threshold voltage ($CS1$) | $T_J = 25^\circ\text{C}$ | | | 0.5 | | V |
| | | over full operating junction temperature | | 0.45 | 0.55 | | |
| | Cycle skip threshold voltage ($CS2$) | Resets SS capacitor; auto restart | $T_J = 25^\circ\text{C}$ | | 0.5 | | V |
| | | | $T_J = T_{low}$ to T_{high} | 0.45 | 0.55 | | |
| | Leading edge blanking time ($CS1$) | | | | 50 | | ns |
| | $CS1$ sink impedance (clocked) | $CS1 = 0.4\text{ V}$ | $T_J = 25^\circ\text{C}$ | | 30 | | Ω |
| | | | $T_J = T_{low}$ to T_{high} | | 50 | | |
| | $CS1$ sink impedance (post fault discharge) | $CS1 = 0.6\text{ V}$ | $T_J = 25^\circ\text{C}$ | | 15 | | Ω |
| | | | $T_J = T_{low}$ to T_{high} | | 30 | | |
| | $CS2$ sink impedance (post fault discharge) | $CS2 = 0.6\text{ V}$ | $T_J = 25^\circ\text{C}$ | | 55 | | Ω |
| | | | $T_J = T_{low}$ to T_{high} | | 95 | | |
| | $CS1$ and $CS2$ leakage current | $CS = CS$ Threshold – 100 mV | $T_J = T_{low}$ to T_{high} | | | 1 | μA |

(1) All electrical characteristics having room temperature limits are tested during production with $T_A = T_J = 25^\circ\text{C}$. All hot and cold limits are specified by correlating the electrical characteristics to process and temperature variations and applying statistical process control.

(2) Device thermal limitations may limit usable range.

Electrical Characteristics (continued)

Typical limits are for $T_J = 25^\circ\text{C}$, and minimum and maximum limits apply over the operating junction temperature range (-40°C to 125°C). $V_{IN} = 48\text{ V}$, $V_{CC} = 10\text{ V}$, $R_T = 31.3\text{ k}\Omega$, $R_{SET} = 27.4\text{ k}\Omega$ unless otherwise stated ⁽¹⁾

| PARAMETER | TEST CONDITIONS | | MIN | TYP | MAX | UNIT |
|---|---|-------------------------------|------|------|-----|---------------|
| SOFT-START | | | | | | |
| Soft-start current source normal | $T_J = 25^\circ\text{C}$ | | 22 | | | μA |
| | over full operating junction temperature | | 17 | 27 | | |
| Soft-start current source following a CS2 event | $T_J = 25^\circ\text{C}$ | | 1 | | | μA |
| | over full operating junction temperature | | 0.5 | 1.5 | | |
| OSCILLATOR | | | | | | |
| Frequency1 | $T_A = 25^\circ\text{C}$, | | 180 | 200 | 220 | kHz |
| | $T_J = T_{low}$ to T_{high} | | 175 | 225 | | |
| Frequency2 | $R_T = 10.4\text{ k}\Omega$ | $T_A = 25^\circ\text{C}$, | 580 | | | kHz |
| | | $T_J = T_{low}$ to T_{high} | 510 | 650 | | |
| Sync threshold | | | 2 | | | V |
| Min sync pulse width | $T_J = T_{low}$ to T_{high} | | 100 | | | ns |
| Sync frequency range | $T_J = T_{low}$ to T_{high} | | 160 | | | kHz |
| PWM COMPARATOR | | | | | | |
| Delay to output | COMP step 5 V to 0 V, Time to onset of OUT_A transition low | | 40 | | | ns |
| Duty cycle range | $T_J = T_{low}$ to T_{high} | | 0% | 80% | | |
| COMP to PWM offset | $T_A = 25^\circ\text{C}$, | | 1 | | | V |
| | $T_J = T_{low}$ to T_{high} | | 0.7 | 1.3 | | |
| COMP open-circuit voltage | $T_J = T_{low}$ to T_{high} | | 4.3 | 5.9 | | V |
| COMP short-circuit current | COMP = 0 V | $T_A = 25^\circ\text{C}$, | 1 | | | mA |
| | | $T_J = T_{low}$ to T_{high} | 0.6 | 1.4 | | |
| VOLT × SECOND CLAMP | | | | | | |
| Ramp clamp level | Delta RAMP measured from onset of OUT_A to Ramp peak, COMP = 5 V | $T_A = 25^\circ\text{C}$, | 2.5 | | | V |
| | | $T_J = T_{low}$ to T_{high} | 2.4 | 2.6 | | |
| UVLO SHUTDOWN | | | | | | |
| Undervoltage shutdown threshold | $T_A = 25^\circ\text{C}$, | | 2.5 | | | V |
| | $T_J = T_{low}$ to T_{high} | | 2.44 | 2.56 | | |
| Undervoltage shutdown hysteresis | $T_A = 25^\circ\text{C}$, | | 20 | | | μA |
| | $T_J = T_{low}$ to T_{high} | | 16 | 24 | | |
| OUTPUT SECTION | | | | | | |
| OUT_A high saturation | MOS device at $I_{out} = -10\text{ mA}$ | $T_A = 25^\circ\text{C}$, | 5 | | | Ω |
| | | $T_J = T_{low}$ to T_{high} | 10 | | | |
| OUTPUT_A peak current sink | Bipolar Device at $V_{CC}/2$ | | 3 | | | A |
| OUT_A low saturation | MOS device at $I_{out} = 10\text{ mA}$ | $T_A = 25^\circ\text{C}$, | 6 | | | Ω |
| | | $T_J = T_{low}$ to T_{high} | 9 | | | |
| OUTPUT_A rise time | $C_{gate} = 2.2\text{ nF}$ | | 20 | | | ns |
| OUTPUT_A fall time | $C_{gate} = 2.2\text{ nF}$ | | 15 | | | ns |
| OUT_B high saturation | MOS device at $I_{out} = -10\text{ mA}$ | $T_A = 25^\circ\text{C}$, | 10 | | | Ω |
| | | $T_J = T_{low}$ to T_{high} | 20 | | | |
| OUTPUT_B peak current sink | Bipolar device at $V_{CC}/2$ | | 1 | | | A |

Electrical Characteristics (continued)

Typical limits are for $T_J = 25^\circ\text{C}$, and minimum and maximum limits apply over the operating junction temperature range (-40°C to 125°C). $V_{IN} = 48\text{ V}$, $V_{CC} = 10\text{ V}$, $R_T = 31.3\text{ k}\Omega$, $R_{SET} = 27.4\text{ k}\Omega$ unless otherwise stated ⁽¹⁾

| PARAMETER | | TEST CONDITIONS | | MIN | TYP | MAX | UNIT |
|------------------------------|---|-------------------------------|--|-----|-----|-----|------------------|
| OUT_B low saturation | MOS device at I _{out} = 10 mA | $T_A = 25^\circ\text{C}$, | | | 12 | | Ω |
| | | $T_J = T_{low}$ to T_{high} | | | | 18 | |
| OUTPUT_B rise time | $C_{gate} = 1\text{ nF}$ | | | | 20 | | ns |
| OUTPUT_B fall time | $C_{gate} = 1\text{ nF}$ | | | | 15 | | ns |
| OUTPUT TIMING CONTROL | | | | | | | |
| Overlap time | $R_{SET} = 38\text{ k}\Omega$ connected to GND, 50% to 50% transitions | $T_A = 25^\circ\text{C}$, | | | 105 | | ns |
| | | $T_J = T_{low}$ to T_{high} | | 75 | | 135 | |
| Dead time | $R_{SET} = 29.5\text{ k}\Omega$ connected to REF, 50% to 50% transitions | $T_A = 25^\circ\text{C}$, | | | 105 | | ns |
| | | $T_J = T_{low}$ to T_{high} | | 75 | | 135 | |
| THERMAL SHUTDOWN | | | | | | | |
| T_{SD} | Thermal shutdown threshold | | | | 165 | | $^\circ\text{C}$ |
| | Thermal shutdown hysteresis | | | | 25 | | $^\circ\text{C}$ |

6.6 Typical Characteristics

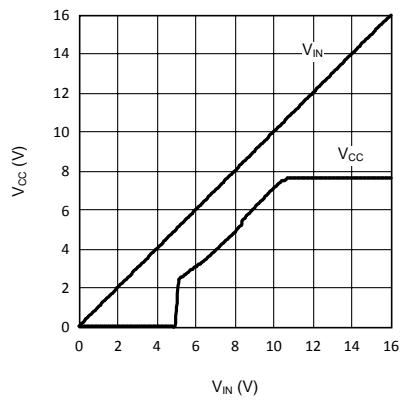

Figure 1. V_{CC} Regulator Start-Up Characteristics, V_{CC} vs V_{IN}

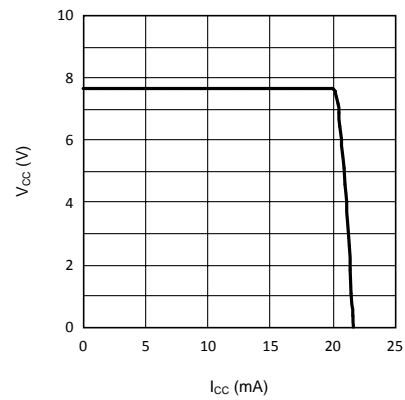

Figure 2. V_{CC} vs I_{CC}

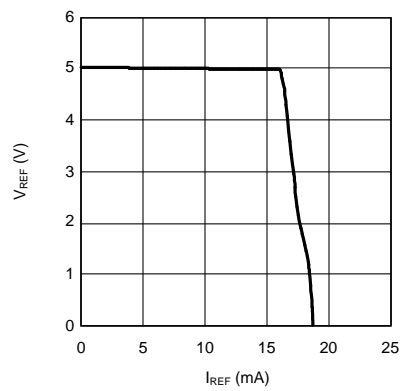

Figure 3. V_{REF} vs I_{REF}

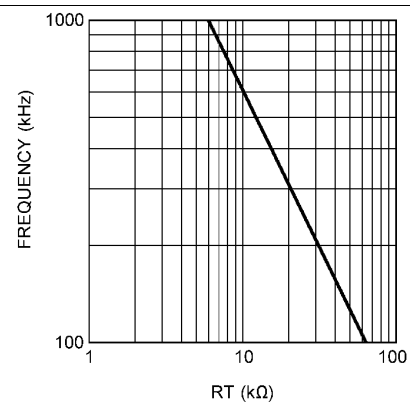

Figure 4. Oscillator Frequency vs R_T

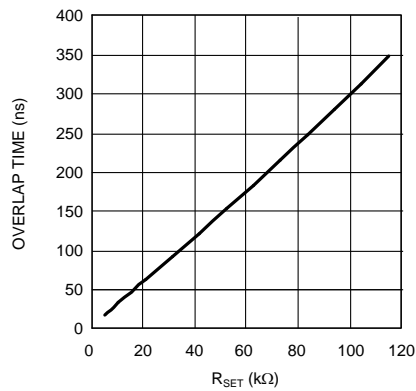
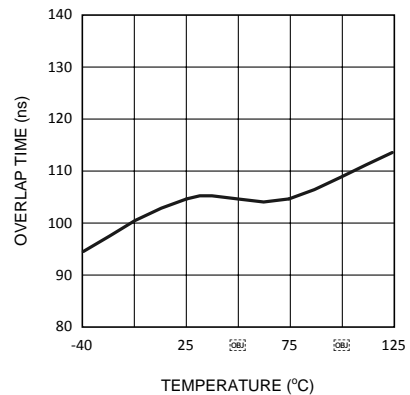

Figure 5. Overlap Time vs R_{SET}



$R_{SET} = 38\text{ K}$

Figure 6. Overlap Time vs Temperature

Typical Characteristics (continued)

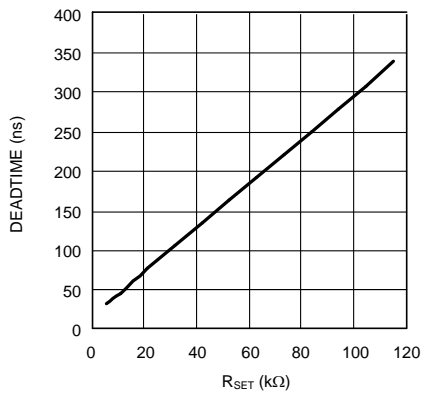
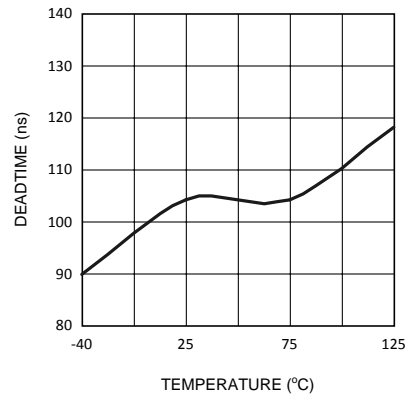

Figure 7. Dead Time vs R_{SET}



R_{SET} = 29.5 K

Figure 8. Dead Time vs Temperature

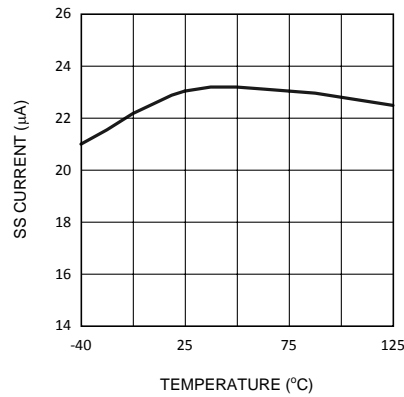

Figure 9. SS Pin Current vs Temperature

7 Detailed Description

7.1 Overview

The LM5025A PWM controller contains all of the features necessary to implement active clamp / reset technique voltage-mode controlled power converters. Synchronous rectification allows higher conversion efficiency and greater power density than conventional PN or Schottky rectifier techniques. The high voltage start-up regulator of the LM5025A can be configured to operate with input voltages ranging from 13 V to 90 V. Additional features include line undervoltage lockout, cycle-by-cycle current limit, voltage feed-forward compensation, hiccup mode fault protection with adjustable delays, soft-start, a 1-MHz capable oscillator with synchronization capability, precision reference, and thermal shutdown. These features simplify the design of active voltage-mode active clamp / reset DC-DC power converters.

LM5025A

SNVS293F – DECEMBER 2004 – REVISED AUGUST 2016

www.ti.com

7.2 Functional Block Diagram

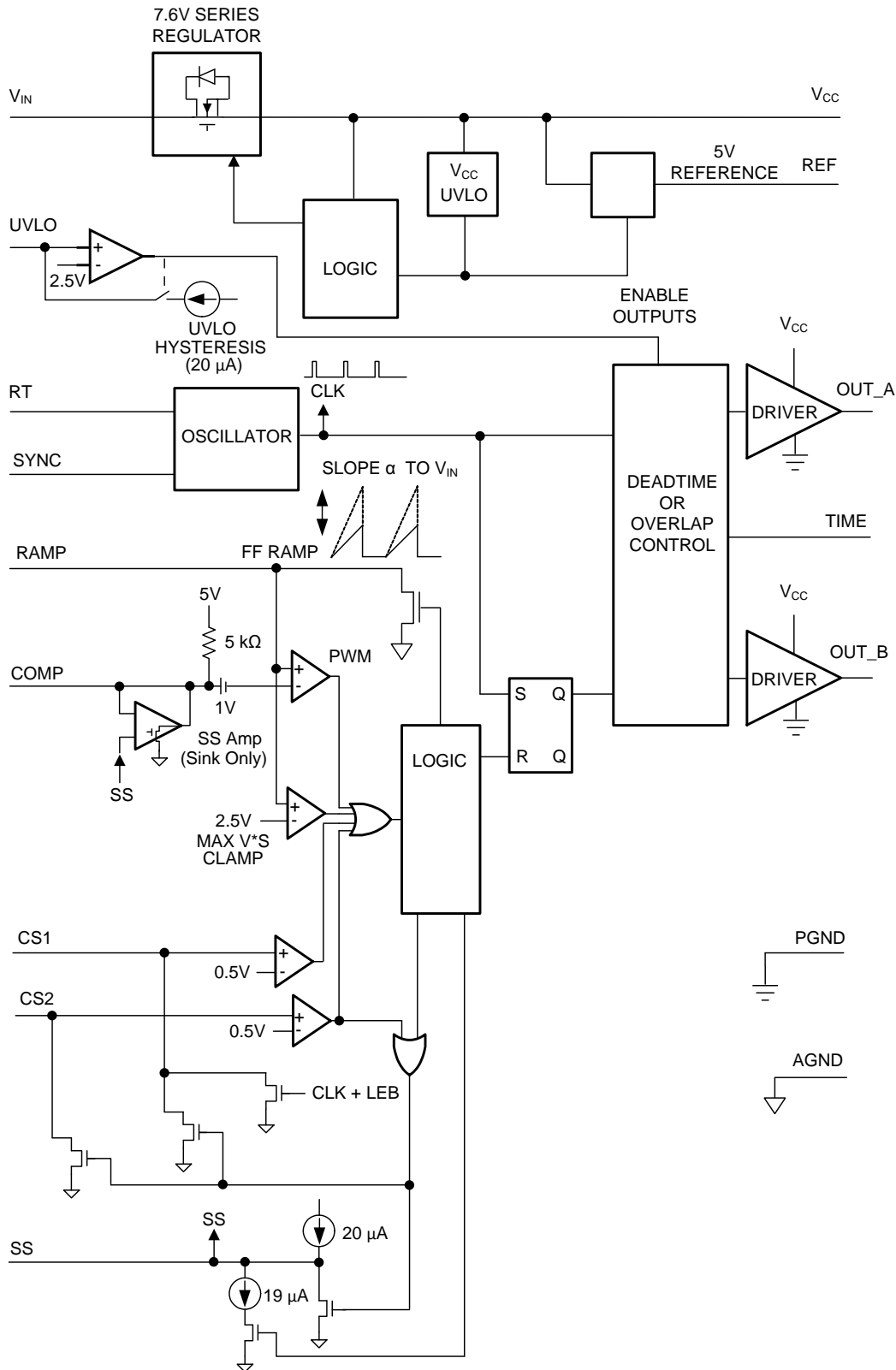

Copyright © 2016, Texas Instruments Incorporated

7.3 Feature Description

7.3.1 High-Voltage Start-Up Regulator

The LM5025A contains an internal high-voltage start-up regulator that allows the input pin (V_{IN}) to be connected directly to the line voltage. The regulator output is internally current-limited to 20 mA. When power is applied, the regulator is enabled and sources current into an external capacitor connected to the V_{CC} pin. The recommended capacitance range for the V_{CC} regulator is 0.1 μ F to 100 μ F. When the voltage on the V_{CC} pin reaches the regulation point of 7.6 V and the internal voltage reference (REF) reaches its regulation point of 5 V, the controller outputs are enabled. The outputs remain enabled until V_{CC} falls below 6.2 V or the line undervoltage lockout detector indicates that V_{IN} is out of range. In typical applications, an auxiliary transformer winding is connected through a diode to the V_{CC} pin. This winding must raise the V_{CC} voltage above 8 V to shut off the internal start-up regulator. Powering V_{CC} from an auxiliary winding improves efficiency while reducing the controller power dissipation.

When the converter auxiliary winding is inactive, external current draw on the V_{CC} line must be limited so the power dissipated in the start-up regulator does not exceed the maximum power dissipation of the controller.

An external start-up regulator or other bias rail can be used instead of the internal start-up regulator by connecting the V_{CC} and the V_{IN} pins together and feeding the external bias voltage into the two pins.

7.3.2 Line Undervoltage Detector

The LM5025A contains a line undervoltage lockout (UVLO) circuit. An external setpoint voltage divider from V_{IN} to GND, sets the operational range of the converter. The divider must be designed such that the voltage at the UVLO pin is greater than 2.5 V when V_{IN} is in the desired operating range. If the undervoltage threshold is not met, both outputs are disabled, all other functions of the controller remain active. UVLO hysteresis is accomplished with an internal 20- μ A current source that is switched ON or OFF into the impedance of the setpoint divider. When the UVLO threshold is exceeded, the current source is activated to instantly raise the voltage at the UVLO pin. When the UVLO pin voltage falls below the 2.5-V threshold, the current source is turned off, causing the voltage at the UVLO pin to fall. The UVLO pin can also be used to implement a remote enable and disable function. Pulling the UVLO pin below the 2.5-V threshold disables the PWM outputs.

7.3.3 PWM Outputs

The relative phase of the main (OUT_A) and active clamp outputs (OUT_B) can be configured for the specific application. For active clamp configurations using a ground-referenced P-channel clamp switch, the two outputs must be in-phase with the active clamp output overlapping the main output. For active clamp configurations using a high-side N-channel switch, the active clamp output must be out-of-phase with main output, and there must be a dead time between the two gate drive pulses. A distinguishing feature of the LM5025A is the ability to accurately configure either dead time (both OFF) or overlap time (both ON) of the gate driver outputs. The overlap and dead-time magnitude is controlled by the resistor value connected to the TIME pin of the controller. The opposite end of the resistor can be connected to either REF for dead-time control or GND for overlap control. The internal configuration detector senses the connection and configures the phase relationship of the main and active clamp outputs. The magnitude of the overlap and dead time can be calculated in [Equation 1](#) and [Equation 2](#).

$$\text{Overlap Time (ns)} = 2.8 \times R_{SET} - 1.2 \quad (1)$$

$$\text{Dead Time (ns)} = 2.9 \times R_{SET} + 20$$

where

- R_{SET} in $k\Omega$
 - Time in ns
- (2)

Feature Description (continued)

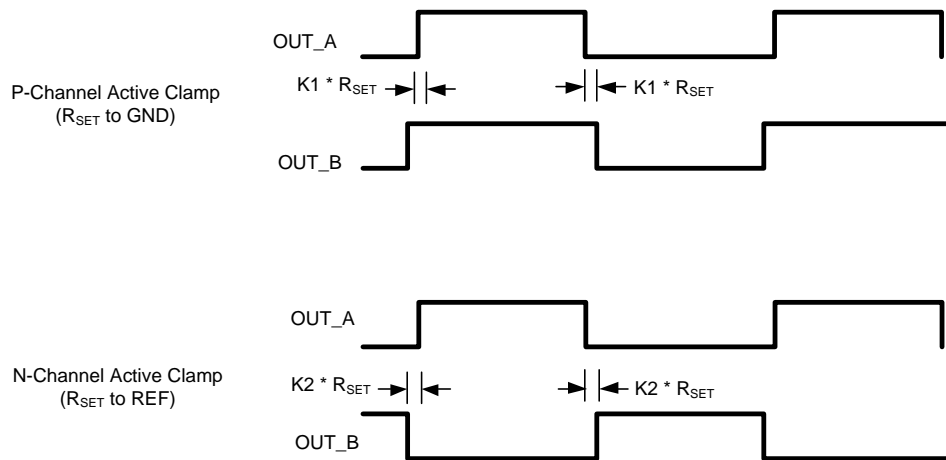

Figure 10. PWM Outputs

7.3.4 Compound Gate Drivers

The LM5025A contains two unique compound gate drivers, which parallel both MOS and Bipolar devices to provide high-drive current throughout the entire switching event. The bipolar device provides most of the drive current capability and provides a relatively constant sink current which is ideal for driving large power MOSFETs. As the switching event nears conclusion and the bipolar device saturates, the internal MOS device continues to provide a low impedance to complete the switching event.

During turnoff at the Miller plateau region, typically around 2 V to 3 V, is where gate driver current capability is needed most. The resistive characteristics of all MOS gate drivers are adequate for turnon because the supply to output voltage differential is fairly large at the Miller region. During turnoff however, the voltage differential is small and the current source characteristic of the bipolar gate driver is beneficial to provide fast drive capability.

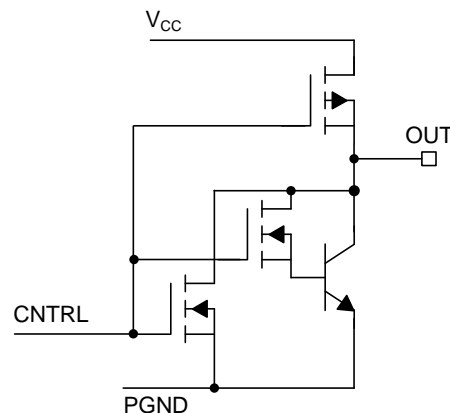

Figure 11. Compound Gate Drivers

7.3.5 PWM Comparator

The PWM comparator compares the ramp signal (RAMP) to the loop error signal (COMP). This comparator is optimized for speed to achieve minimum controllable duty cycles. The internal 5-kΩ pullup resistor, connected between the internal 5-V reference and COMP, can be used as the pullup for an optocoupler. The comparator polarity is such that 0 V on the COMP pin produces a zero duty cycle on both gate driver outputs.

Feature Description (continued)

7.3.6 Volt Second Clamp

The Volt × Second Clamp comparator compares the ramp signal (RAMP) to a fixed 2.5-V reference. By proper selection of RFF and CFF, the maximum ON-time of the main switch can be set to the desired duration. The ON-time set by Volt × Second Clamp varies inversely with the line voltage because the RAMP capacitor is charged by a resistor connected to V_{IN} while the threshold of the clamp is a fixed voltage (2.5 V). An example illustrates the use of the Volt × Second Clamp comparator to achieve a 50% duty cycle limit, at 200 KHz, at a 48-V line input: A 50% duty cycle at a 200 KHz requires a 2.5 μs of ON-time. At 48-V input the Volt × Second product is 120 V × μs (48 V × 2.5 μs). To achieve this clamp level, use [Equation 3](#) and [Equation 4](#):

$$R_{FF} \times C_{FF} = V_{IN} \times T_{ON} / 2.5 \text{ V} \quad (3)$$

$$48 \times 2.5 \mu / 2.5 = 48 \mu \quad (4)$$

Select C_{FF} = 470 pF

R_{FF} = 102 kΩ

The recommended capacitor value range for CFF is 100 pF to 1000 pF.

The C_{FF} ramp capacitor is discharged at the conclusion of every cycle by an internal discharge switch controlled by either the internal clock or by the V × S Clamp comparator, whichever event occurs first.

7.3.7 Current Limit

The LM5025A contains two modes of overcurrent protection. If the sense voltage at the CS1 input exceeds 0.5 V the present power cycle is terminated (cycle-by-cycle current limit). If the sense voltage at the CS2 input exceeds 0.5 V, the controller terminates the present cycle, discharge the soft-start capacitor and reduce the soft-start current source to 1 μA. The soft-start (SS) capacitor is released after being fully discharged and slowly charges with a 1-μA current source. When the voltage at the SS pin reaches approximately 1 V, the PWM comparator produces the first output pulse at OUT_A. After the first pulse occurs, the soft-start current source reverts to the normal 20-μA level. Fully discharging and then slowly charging the SS capacitor protects a continuously overloaded converter with a low duty cycle hiccup mode.

These two modes of overcurrent protection allow the user great flexibility to configure the system behavior in over-load conditions. If it is desired for the system to act as a current source during an overload, then the CS1 cycle-by-cycle current limiting must be used. In this case the current sense signal must be applied to the CS1 input and the CS2 input must be grounded. If during an overload condition it is desired for the system to briefly shutdown, followed by soft-start retry, then the CS2 hiccup current limiting mode must be used. In this case the current sense signal must be applied to the CS2 input and the CS1 input must be grounded. This shutdown and soft-start retry repeats indefinitely while the overload condition remains. The hiccup mode greatly reduces the thermal stresses to the system during heavy overloads. The cycle-by-cycle mode has higher system thermal dissipations during heavy overloads, but provides the advantage of continuous operation for short duration overload conditions.

It is possible to use both overcurrent modes concurrently, whereby slight overload conditions activate the CS1 cycle-by-cycle mode while more severe overloading activates the CS2 hiccup mode. Generally the CS1 input is always configured to monitor the main switch FET current each cycle. The CS2 input can be configured in several different ways depending upon the system requirements.

- The CS2 input can also be set to monitor the main switch FET current except scaled to a higher threshold than CS1
- An external overcurrent timer can be configured which trips after a predetermined overcurrent time, driving the CS2 input high, initiating a hiccup event.
- In a closed-loop voltage regulation system, the COMP input rises to saturation when the cycle-by-cycle current limit is active. An external filter and delay timer and voltage divider can be configured between the COMP pin and the CS2 pin to scale and delay the COMP voltage. If the CS2 pin voltage reaches 0.5 V a hiccup event will initiate.

TI recommends a small RC filter placed near the controller for each of the CS pins. The CS1 input has an internal FET which discharges the current sense filter capacitor at the conclusion of every cycle, to improve dynamic performance. This same FET remains on an additional 50 ns at the start of each main switch cycle to attenuate the leading edge spike in the current sense signal. The CS2 discharge FET only operates following a CS2 event, UVLO, and thermal shutdown.

Feature Description (continued)

The LM5025A CS comparators are very fast and may respond to short duration noise pulses. Layout considerations are critical for the current sense filter and sense resistor. The capacitor associated with the CS filter must be placed very close to the device and connected directly to the pins of the IC (CS and GND). If a current sense transformer is used, both leads of the transformer secondary must be routed to the filter network, which must be placed close to the IC. If a sense resistor in the source of the main switch MOSFET is used for current sensing, a low inductance type of resistor is required. When designing with a current sense resistor, all of the noise-sensitive, low-power ground connections must be connected together near the IC GND and a single connection must be made to the power ground (sense resistor ground point).

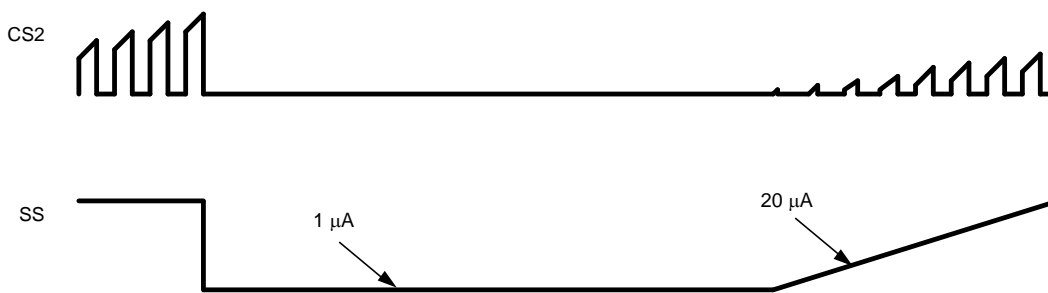

Figure 12. Current Limit

7.3.8 Oscillator and Sync Capability

The LM5025A oscillator is set by a single external resistor connected between the RT pin and GND. To set a desired oscillator frequency (F), the necessary RT resistor can be calculated in [Equation 5](#):

$$RT = (5725/F)^{1.026}$$

where

- F is in kHz and RT in k Ω (5)

The RT resistor must be placed very close to the device and connected directly to the pins of the IC (RT and GND).

A unique feature of LM5025A is the ability to synchronize the oscillator to an external clock with a frequency that is either higher or lower than the frequency of the internal oscillator. The lower frequency sync frequency range is 80% of the free-running internal oscillator frequency. There is no constraint on the maximum SYNC frequency. A minimum pulse width of 100 ns is required for the synchronization clock. If the synchronization feature is not required, the SYNC pin must be connected to GND to prevent any abnormal interference. The internal oscillator can be completely disabled by connecting the RT pin to REF. Once disabled, the sync signal acts directly as the master clock for the controller. Both the frequency and the maximum duty cycle of the PWM controller can be controlled by the SYNC signal (within the limitations of the Volt \times Second Clamp). The maximum duty cycle (D) will be (1-D) of the SYNC signal.

7.3.9 Feed-Forward Ramp

An external resistor (R_{FF}) and capacitor (C_{FF}) connected to V_{IN} and GND are required to create the PWM ramp signal. The slope of the signal at the RAMP pin varies in proportion to the input line voltage. This varying slope provides line feedforward information necessary to improve line transient response with voltage mode control. The RAMP signal is compared to the error signal at the COMP pin by the pulse width modulator comparator to control the duty cycle of the main switch output. The Volt Second Clamp comparator also monitors the RAMP pin and if the ramp amplitude exceeds 2.5 V the present cycle is terminated. The ramp signal is reset to GND at the end of each cycle by either the internal clock or the Volt Second comparator, whichever occurs first.

Feature Description (continued)

7.3.10 Soft Start

The soft-start feature allows the power converter to gradually reach the initial steady-state operating point, thus reducing start-up stresses and surges. At power on, a 20- μ A current is sourced out of the soft-start pin (SS) into an external capacitor. The capacitor voltage ramps up slowly and limits the COMP pin voltage and therefore the PWM duty cycle. In the event of a fault as determined by V_{CC} undervoltage, line undervoltage (UVLO) or second level current limit, the output gate drivers are disabled, and the soft-start capacitor is fully discharged. When the fault condition is no longer present a soft-start sequence is initiated. Following a second level current limit detection (CS2), the soft-start current source is reduced to 1 μ A until the first output pulse is generated by the PWM comparator. The current source returns to the nominal 20- μ A level after the first output pulse (approximately 1 V at the SS pin).

7.4 Device Functional Modes

The LM5025A active clamp voltage mode PWM controller has six functional modes:

- UVLO Mode
- Soft-Start Mode
- Normal Operation Mode
- Cycle-by-Cycle Current Limit Mode
- Hiccup Mode
- Thermal Shut Down Mode

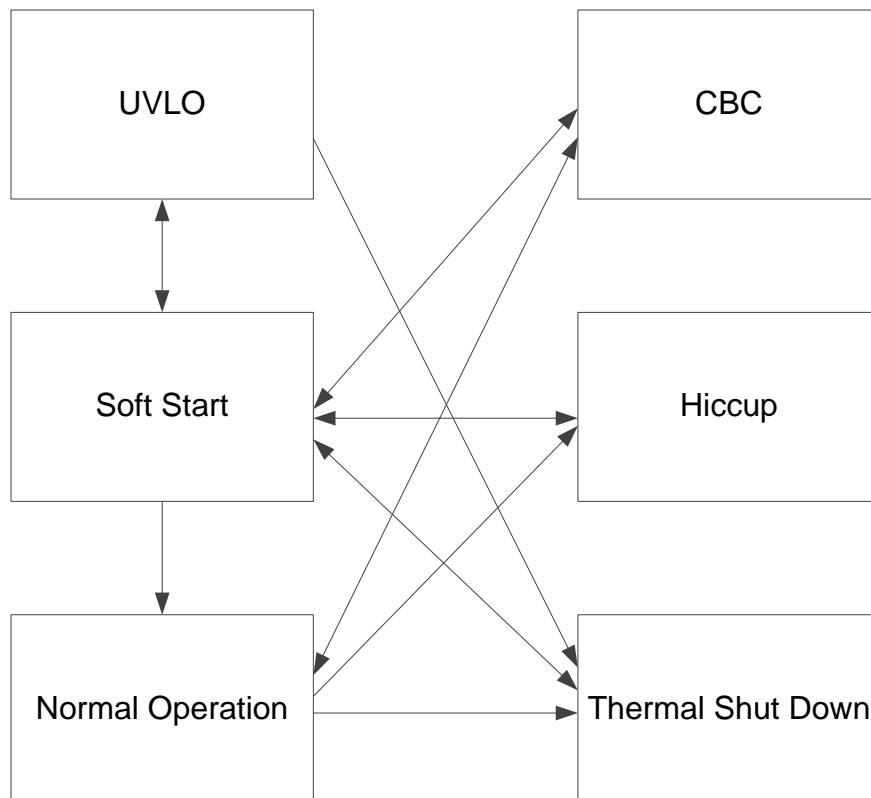

Figure 13. Functional Mode Transition Diagram

8 Application and Implementation

NOTE

Information in the following applications sections is not part of the TI component specification, and TI does not warrant its accuracy or completeness. TI's customers are responsible for determining suitability of components for their purposes. Customers should validate and test their design implementation to confirm system functionality.

8.1 Application Information

The LM5025A PWM controller contains all of the features necessary to implement power converters using the active clamp and reset technique. This section provides design guidance for a typical active clamp forward converter design. An actual application schematic of a 36-V to 78-V input, 3.3-V, 30-A output active clamp forward converter is also provided in [Figure 22](#).

8.2 Typical Application

[Figure 14](#) shows a simplified schematic of an active clamp forward power converter.

Power converters based on the forward topology offer high-efficiency and good power-handling capability in applications up to several hundred Watts. The operation of the transformer in a forward topology does not inherently self-reset each power switching cycle, a mechanism to reset the transformer is required. The active clamp reset mechanism is presently finding extensive use in medium-level power converters in the range of 50 W to 200 W.

The forward converter is derived from the Buck topology family, employing a single modulating power switch. The main difference between the topologies is the forward topology employs a transformer to provide input and output ground isolation and a step-down or step-up function.

Each cycle, the main primary switch turns on and applies the input voltage across the primary winding. The transformer turns the voltage to a lower-level on the secondary side. The clamp capacitor along with the reset switch reverse biases the transformer primary each cycle when the main switch turns off. This reverse voltage resets the transformer. The clamp capacitor voltage is $V_{IN} / (1-D)$.

The secondary rectification employs self-driven synchronous rectification to maintain high-efficiency and ease of drive.

Feedback from the output is processed by an amplifier and reference, generating an error voltage, which is coupled back to the primary side control through an opto-coupler. The LM5025A voltage mode controller pulse width modulates the error signal with a ramp signal derived from the input voltage. Deriving the ramp signal slope from the input voltage provides line feedforward, which improves line transient rejection. The LM5025A also provides a controlled delay necessary for the reset switch.

Typical Application (continued)

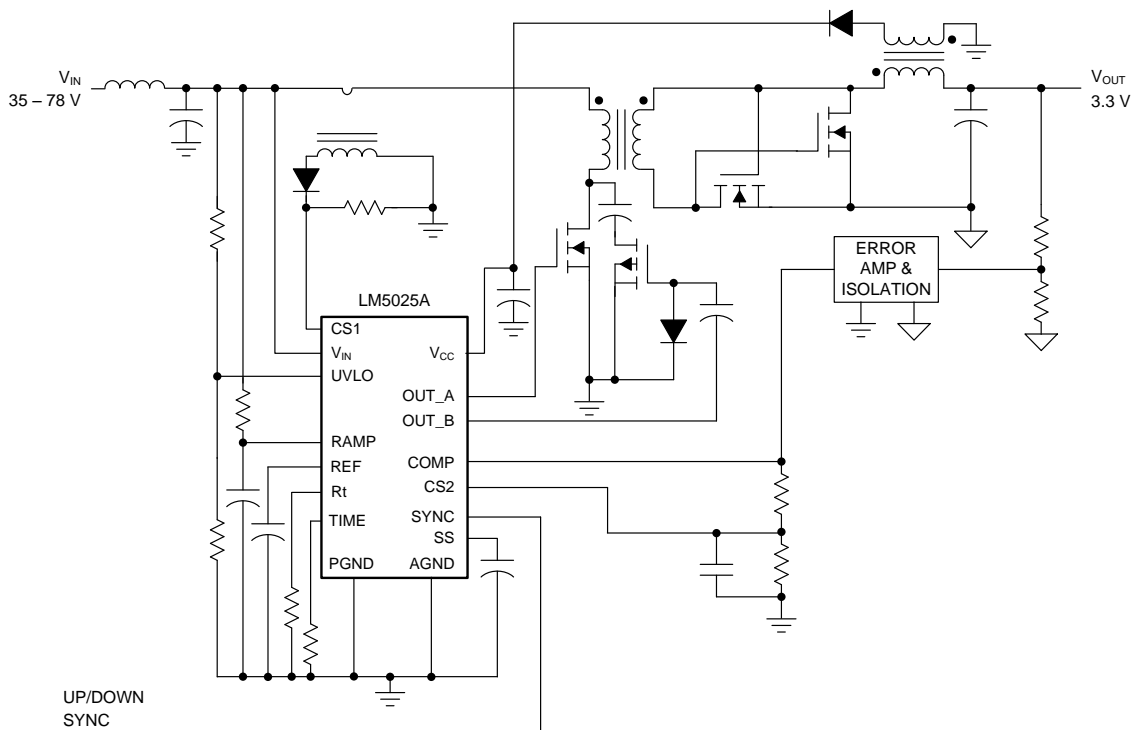

Copyright © 2016, Texas Instruments Incorporated

Figure 14. Simplified Active Clamp Forward Power Converter

8.2.1 Design Requirements

This typical application provides an example of a fully-functional power converter based on the active clamp forward topology in an industry standard half-brick footprint.

The design requirements are:

- Input: 36 V to 78 V (100-V peak)
- Output voltage: 3.3 V
- Output current: 0 A to 30 A
- Measured efficiency: 90.5% at 30 A, 92.5% at 15 A
- Frequency of operation: 230 kHz
- Board size: 2.3 × 2.4 × 0.5 inches
- Load regulation: 1%
- Line regulation: 0.1%
- Line UVLO, hiccup current limit

8.2.2 Detailed Design Procedure

Before the controller design begins, the power stage design must be completed. This section describes the calculations needed to configure the LM5025A controller to meet the power stage design requirements.

8.2.2.1 Oscillator

The desired switching frequency F is set by a resistor connected between RT pin and ground. The resistance value R_T is calculated from [Equation 6](#):

Typical Application (continued)

$$R_T = (5725/F)^{1.026}$$

where

- F is in kHz and R_T in k Ω (6)

8.2.2.2 Soft-Start Ramp Time and Hiccup Interval

The soft-start ramp time and hiccup interval is programmed by a capacitor (C_{SS}) on the SS pin to ground. The soft-start ramp time is determined by comparing the SS pin voltage with COMP pin voltage. When the SS voltage is less than COMP voltage, the COMP voltage is clamped by SS voltage. The PWM duty is limited by the clamped COMP voltage, so that soft start can be achieved. The first PWM pulse is generated after COMP voltage reaches 1 V. So the soft-start ramp time of the output voltage can be estimated by [Equation 7](#):

$$T_{SS} \text{ (ms)} = C_{SS} \text{ (nF)} \times \frac{V_{SS} - 1 \text{ V}}{20 \mu\text{A}}$$

where

- V_{SS} is the steady-state COMP pin voltage. This voltage is determined by the output voltage, voltage divider, and the compensation network. (7)

In hiccup mode, the SS current source is reduced to 1 μA . When the first PWM pulse is generated, the current source switches to 20 μA , and the power supply tries to start up again. The hiccup interval can be calculated by [Equation 8](#):

$$T_{\text{hiccup}} \text{ (ms)} = C_{SS} \text{ (nF)} \times \frac{1 \text{ V}}{1 \mu\text{A}} \quad (8)$$

8.2.2.3 Feedforward Ramp and Maximum On-Time Clamp

An example illustrates the use of the Volt \times Second Clamp comparator to achieve a 50% duty cycle limit, at 200 KHz, at a 48-V line input: A 50% duty cycle at a 200 KHz requires a 2.5 μs of ON-time. At 48-V input the Volt \times Second product is 120 V \times μs (48 V \times 2.5 μs). To achieve this clamp level, see [Equation 9](#) and [Equation 10](#):

$$R_{FF} \times C_{FF} = V_{IN} \times T_{ON} / 2.5 \text{ V} \quad (9)$$

$$48 \times 2.5 \mu\text{F} / 2.5 = 48 \mu\text{F} \quad (10)$$

Select $C_{FF} = 470 \text{ pF}$

$R_{FF} = 102 \text{ k}\Omega$

The recommended capacitor value range for C_{FF} is 100 pF to 1000 pF.

8.2.2.4 Dead Times

The magnitude of the overlap and dead time can be calculated as follows in [Equation 11](#) and [Equation 12](#):

$$\text{Overlap Time (ns)} = 2.8 \times R_{SET} - 1.2 \quad (11)$$

$$\text{Dead Time (ns)} = 2.9 \times R_{SET} + 20$$

where

- R_{SET} in k Ω , Time in ns (12)

Typical Application (continued)

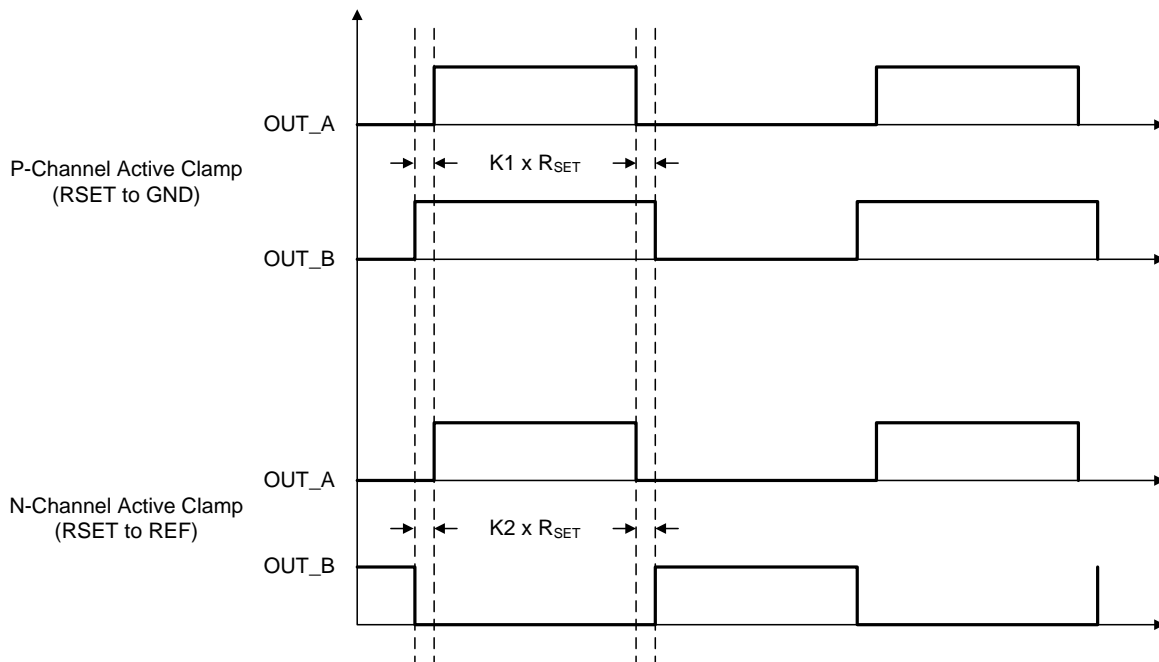
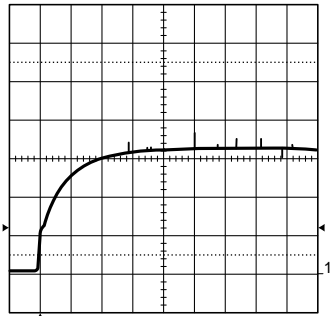

Figure 15. PWM Outputs

Typical Application (continued)

8.2.3 Application Curves



Conditions: input voltage = 48 VDC, output current = 5 A
Trace 1: output voltage Volts/div = 0.5 V
Horizontal resolution = 1 ms/div

Figure 16. Output Voltage During Typical Start-Up

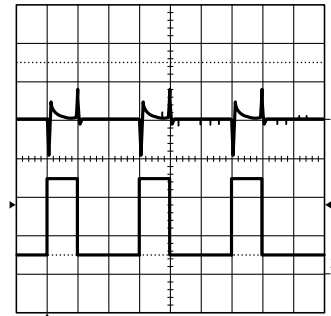

Conditions: input voltage = 48 VDC, output current = 5 A to 25 A
Trace 1: output voltage Volts/div = 0.5 V
Trace 2: output current, Amps/div = 10 A
Horizontal resolution = 1 μ s/div

Figure 17. Transient Response

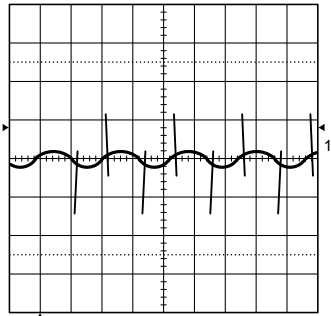

Conditions: input voltage = 48 VDC, output current = 30 A
Bandwidth limit = 25 MHz
Trace 1: output ripple voltage Volts/div = 50 mV
Horizontal resolution = 2 μ s/div

Figure 18. Output Ripple

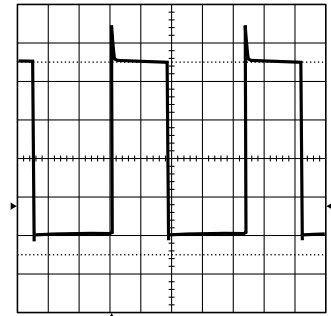

Conditions: input voltage = 38 VDC, output current = 25 A
Trace 1: Q1 drain voltage Volts/div = 20 V
Horizontal resolution = 1 μ s/div

Figure 19. Drain Voltage

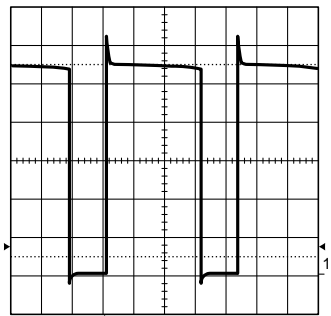

Conditions: input voltage = 78 VDC, output current = 25 A
Trace 1: Q1 drain voltage Volts/div = 20 V
Horizontal resolution = 1 μ s/div

Figure 20. Drain Voltage

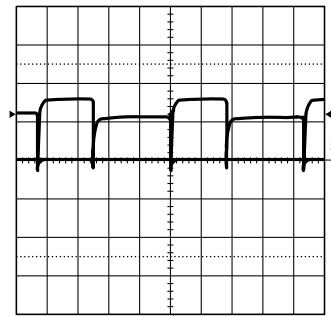

Conditions: input voltage = 48 VDC, output current = 5 A
Synchronous rectifier, Q3 gate Volts/div = 5 V
Trace 1: synchronous rectifier, Q3 gate Volts/div = 5 V
Trace 2: synchronous rectifier, Q5 gate Volts/div = 5 V
Horizontal resolution = 1 μ s/div

Figure 21. Gate Voltages of the Synchronous Rectifiers

8.3 System Example

Figure 22 shows an application circuit with 36-V to 78-V input and 3.3-V, 30-A output capability.

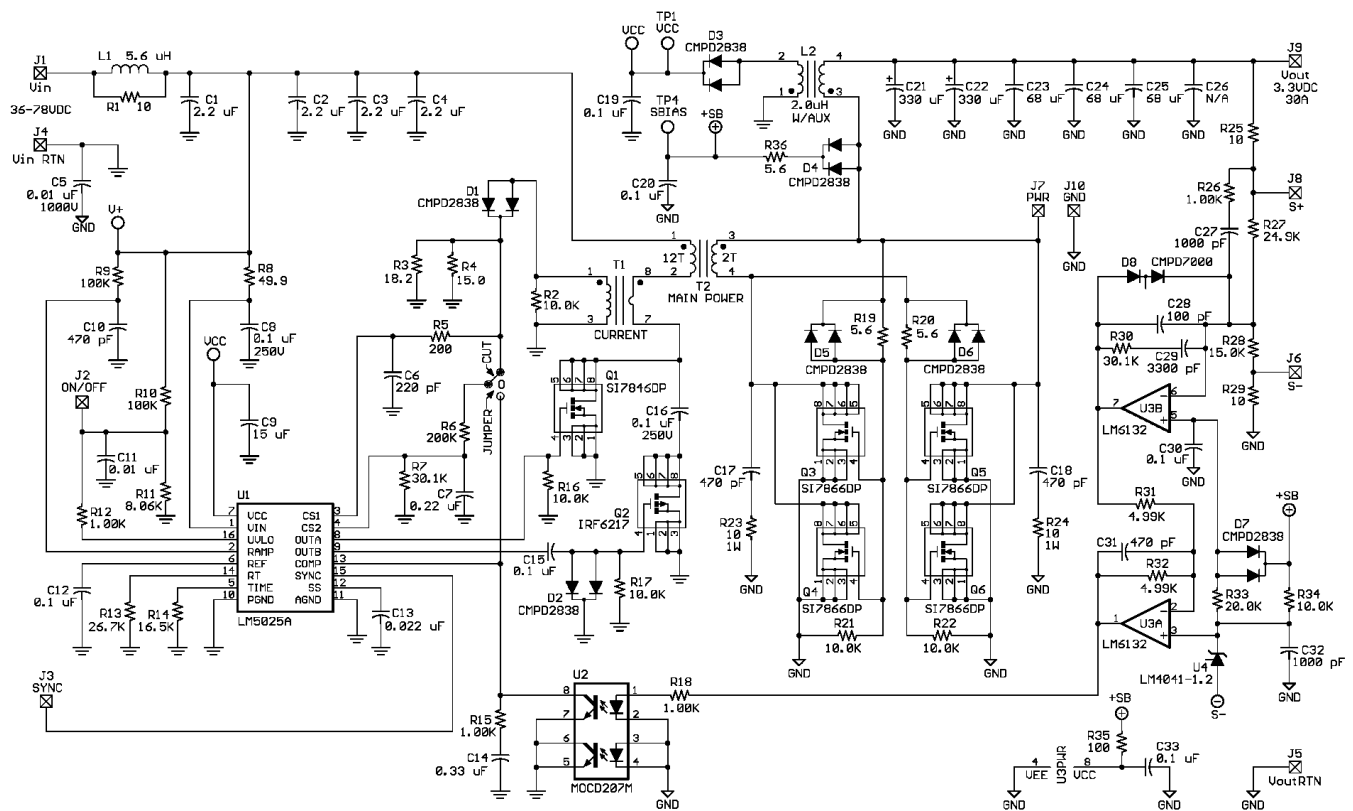

Figure 22. Application Circuit

9 Power Supply Recommendations

The V_{CC} pin is the power supply for the device. There must be a 0.1- μ F to approximately 100- μ F capacitor directly from V_{CC} to ground. REF pin must be bypassed to ground as close as possible to the device using a 0.1- μ F capacitor.

10 Layout

10.1 Layout Guidelines

- Connect two grounds PGND (power ground) and AGND (analog ground) directly as device ground ICGND. The connection must be as close to the pins as possible.
- If there are multiple PCB layers and there is an inner ground layer, use two vias or one big via on GND and connect them to the inner ground layer (ICGND).
- The power stage ground PSGND must be separated with the ICGND. PSGND and ICGND must be connected at a single point close to the device.
- The bypass capacitors to the V_{CC} pin and REF pin must be as close as possible to the pins and ground (ICGND).
- The filtering capacitors connected to CS1 and CS2 pins must have connections as short as possible to ICGND; if an inner ground layer is available, use vias to connect the capacitors to the ground layer (ICGND).
- The resistors and capacitors connected to the timing configuration pins must be as close as possible to the pins and ground (ICGND).

10.2 Layout Example

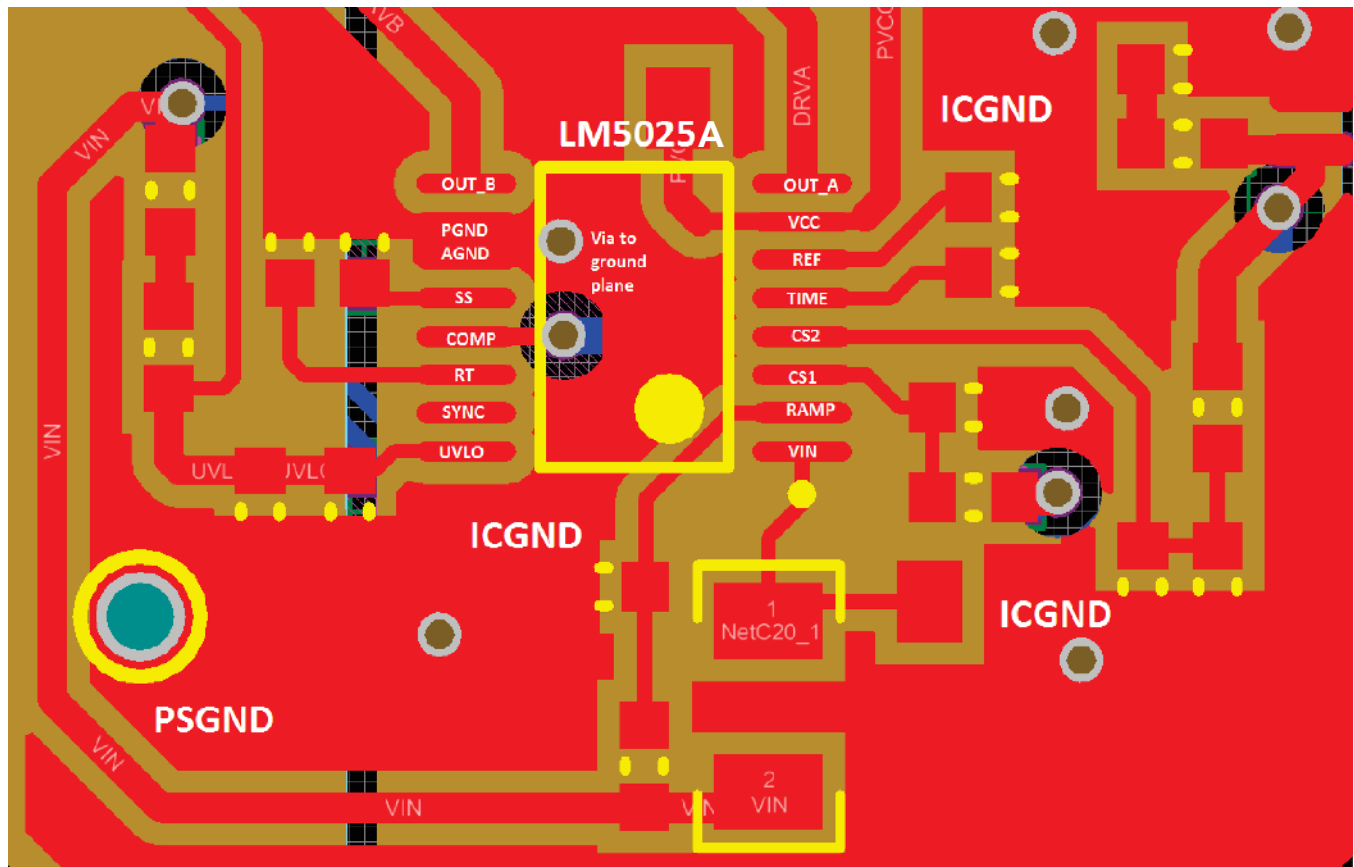

Figure 23. LM5025A Layout Recommendation

10.3 Thermal Protection

Internal thermal shutdown circuitry is provided to protect the integrated circuit in the event the maximum junction temperature is exceeded. When activated, typically at 165°C, the controller is forced into a low-power standby state with the output drivers and the bias regulator disabled. The device restarts after the thermal hysteresis (typically 25°C). During a restart after thermal shutdown, the soft-start capacitor is fully discharged and then charged in the low current mode (1 μ A) similar to a second level current limit event. The thermal protection feature is provided to prevent catastrophic failures from accidental device overheating.

11 Device and Documentation Support

11.1 Documentation Support

11.1.1 Related Documentation

For related documentation, see the following:

[LM5025 Isolated Active Clamp Forward Converter Ref Design User Guide](#) (SNVU096)

11.2 Receiving Notification of Documentation Updates

To receive notification of documentation updates, navigate to the device product folder on ti.com. In the upper right corner, click on *Alert me* to register and receive a weekly digest of any product information that has changed. For change details, review the revision history included in any revised document.

11.3 Community Resources

The following links connect to TI community resources. Linked contents are provided "AS IS" by the respective contributors. They do not constitute TI specifications and do not necessarily reflect TI's views; see TI's [Terms of Use](#).

TI E2E™ Online Community *TI's Engineer-to-Engineer (E2E) Community*. Created to foster collaboration among engineers. At e2e.ti.com, you can ask questions, share knowledge, explore ideas and help solve problems with fellow engineers.

Design Support *TI's Design Support* Quickly find helpful E2E forums along with design support tools and contact information for technical support.

11.4 Trademarks

E2E is a trademark of Texas Instruments.
All other trademarks are the property of their respective owners.

11.5 Electrostatic Discharge Caution



These devices have limited built-in ESD protection. The leads should be shorted together or the device placed in conductive foam during storage or handling to prevent electrostatic damage to the MOS gates.

11.6 Glossary

[SLYZ022](#) — *TI Glossary*.

This glossary lists and explains terms, acronyms, and definitions.

12 Mechanical, Packaging, and Orderable Information

The following pages include mechanical, packaging, and orderable information. This information is the most current data available for the designated devices. This data is subject to change without notice and revision of this document. For browser-based versions of this data sheet, refer to the left-hand navigation.

PACKAGING INFORMATION

| Orderable Device | Status (1) | Package Type | Package Drawing | Pins | Package Qty | Eco Plan (2) | Lead finish/ Ball material (6) | MSL Peak Temp (3) | Op Temp (°C) | Device Marking (4/5) | Samples |
|------------------|---------------|--------------|-----------------|------|-------------|-----------------|--------------------------------------|----------------------|--------------|-------------------------|-------------------------|
| LM5025AMTC/NOPB | ACTIVE | TSSOP | PW | 16 | 92 | RoHS & Green | NIPDAU SN | Level-1-260C-UNLIM | -40 to 125 | L5025A MTC | Samples |
| LM5025AMTCX/NOPB | ACTIVE | TSSOP | PW | 16 | 2500 | RoHS & Green | NIPDAU SN | Level-1-260C-UNLIM | -40 to 125 | L5025A MTC | Samples |
| LM5025ASD/NOPB | ACTIVE | WSON | NHQ | 16 | 1000 | RoHS & Green | SN | Level-1-260C-UNLIM | -40 to 125 | 5025ASD | Samples |
| LM5025ASDX/NOPB | ACTIVE | WSON | NHQ | 16 | 4500 | RoHS & Green | SN | Level-1-260C-UNLIM | -40 to 125 | 5025ASD | Samples |

(1) The marketing status values are defined as follows:

ACTIVE: Product device recommended for new designs.

LIFEBUY: TI has announced that the device will be discontinued, and a lifetime-buy period is in effect.

NRND: Not recommended for new designs. Device is in production to support existing customers, but TI does not recommend using this part in a new design.

PREVIEW: Device has been announced but is not in production. Samples may or may not be available.

OBSELETE: TI has discontinued the production of the device.

(2) **RoHS:** TI defines "RoHS" to mean semiconductor products that are compliant with the current EU RoHS requirements for all 10 RoHS substances, including the requirement that RoHS substance do not exceed 0.1% by weight in homogeneous materials. Where designed to be soldered at high temperatures, "RoHS" products are suitable for use in specified lead-free processes. TI may reference these types of products as "Pb-Free".

RoHS Exempt: TI defines "RoHS Exempt" to mean products that contain lead but are compliant with EU RoHS pursuant to a specific EU RoHS exemption.

Green: TI defines "Green" to mean the content of Chlorine (Cl) and Bromine (Br) based flame retardants meet JS709B low halogen requirements of <=1000ppm threshold. Antimony trioxide based flame retardants must also meet the <=1000ppm threshold requirement.

(3) MSL, Peak Temp. - The Moisture Sensitivity Level rating according to the JEDEC industry standard classifications, and peak solder temperature.

(4) There may be additional marking, which relates to the logo, the lot trace code information, or the environmental category on the device.

(5) Multiple Device Markings will be inside parentheses. Only one Device Marking contained in parentheses and separated by a "-" will appear on a device. If a line is indented then it is a continuation of the previous line and the two combined represent the entire Device Marking for that device.

(6) Lead finish/Ball material - Orderable Devices may have multiple material finish options. Finish options are separated by a vertical ruled line. Lead finish/Ball material values may wrap to two lines if the finish value exceeds the maximum column width.

Important Information and Disclaimer:The information provided on this page represents TI's knowledge and belief as of the date that it is provided. TI bases its knowledge and belief on information provided by third parties, and makes no representation or warranty as to the accuracy of such information. Efforts are underway to better integrate information from third parties. TI has taken and

continues to take reasonable steps to provide representative and accurate information but may not have conducted destructive testing or chemical analysis on incoming materials and chemicals. TI and TI suppliers consider certain information to be proprietary, and thus CAS numbers and other limited information may not be available for release.

In no event shall TI's liability arising out of such information exceed the total purchase price of the TI part(s) at issue in this document sold by TI to Customer on an annual basis.

TAPE AND REEL INFORMATION

QUADRANT ASSIGNMENTS FOR PIN 1 ORIENTATION IN TAPE

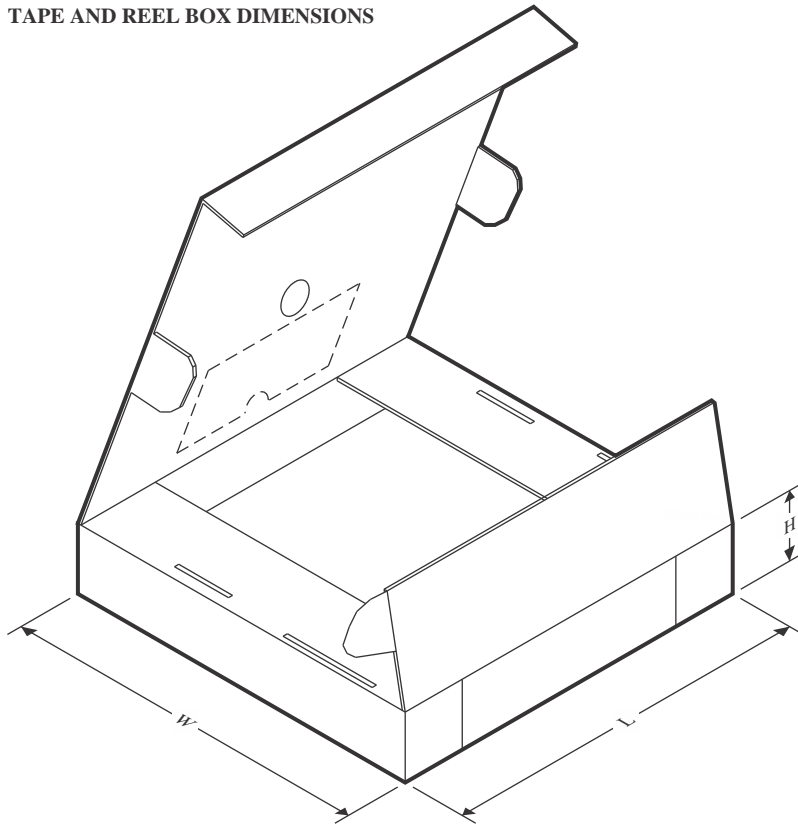

*All dimensions are nominal

| Device | Package Type | Package Drawing | Pins | SPQ | Reel Diameter (mm) | Reel Width W1 (mm) | A0 (mm) | B0 (mm) | K0 (mm) | P1 (mm) | W (mm) | Pin1 Quadrant |
|------------------|--------------|-----------------|------|------|--------------------|--------------------|---------|---------|---------|---------|--------|---------------|
| LM5025AMTCX/NOPB | TSSOP | PW | 16 | 2500 | 330.0 | 12.4 | 6.95 | 5.6 | 1.6 | 8.0 | 12.0 | Q1 |
| LM5025ASD/NOPB | WSON | NHQ | 16 | 1000 | 178.0 | 12.4 | 5.3 | 5.3 | 1.3 | 8.0 | 12.0 | Q1 |
| LM5025ASDX/NOPB | WSON | NHQ | 16 | 4500 | 330.0 | 12.4 | 5.3 | 5.3 | 1.3 | 8.0 | 12.0 | Q1 |

TAPE AND REEL BOX DIMENSIONS

*All dimensions are nominal

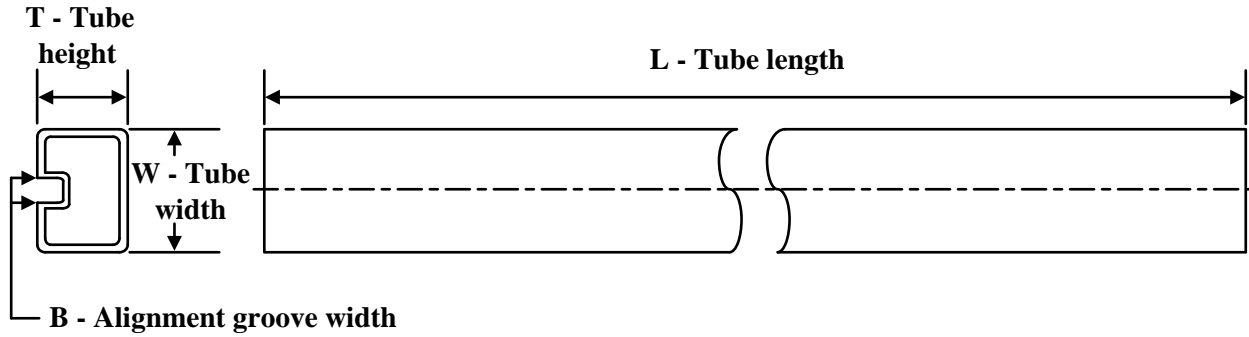
| Device | Package Type | Package Drawing | Pins | SPQ | Length (mm) | Width (mm) | Height (mm) |
|------------------|--------------|-----------------|------|------|-------------|------------|-------------|
| LM5025AMTCX/NOPB | TSSOP | PW | 16 | 2500 | 367.0 | 367.0 | 35.0 |
| LM5025ASD/NOPB | WSON | NHQ | 16 | 1000 | 208.0 | 191.0 | 35.0 |
| LM5025ASDX/NOPB | WSON | NHQ | 16 | 4500 | 367.0 | 367.0 | 35.0 |

TUBE

*All dimensions are nominal

| Device | Package Name | Package Type | Pins | SPQ | L (mm) | W (mm) | T (μm) | B (mm) |
|-----------------|--------------|--------------|------|-----|--------|--------|--------|--------|
| LM5025AMTC/NOPB | PW | TSSOP | 16 | 92 | 530 | 10.2 | 3600 | 3.5 |
| LM5025AMTC/NOPB | PW | TSSOP | 16 | 92 | 495 | 8 | 2514.6 | 4.06 |

NHQ0016A

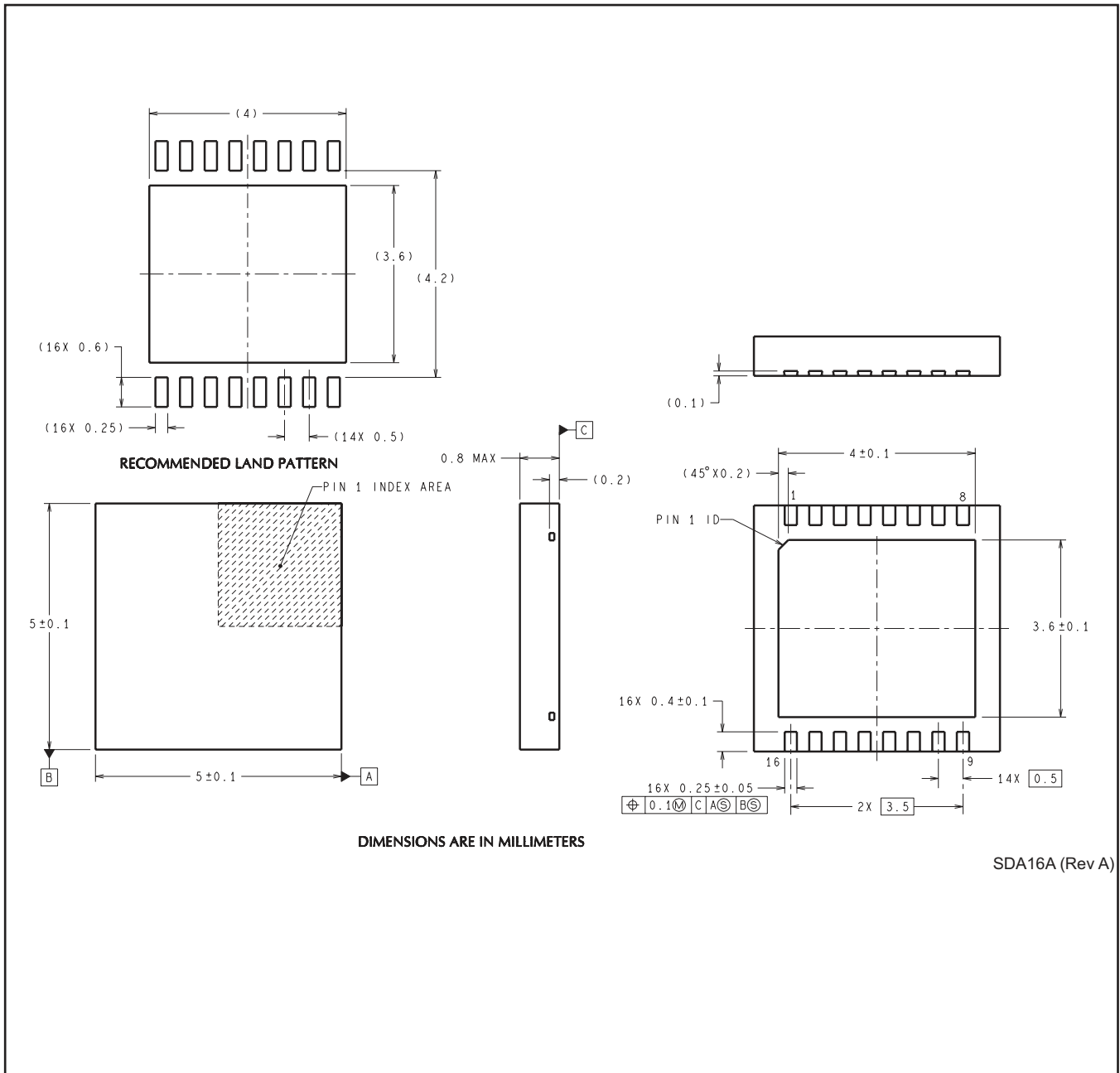

PW0016A



PACKAGE OUTLINE

TSSOP - 1.2 mm max height

SMALL OUTLINE PACKAGE



4220204/A 02/2017

NOTES:

1. All linear dimensions are in millimeters. Any dimensions in parenthesis are for reference only. Dimensioning and tolerancing per ASME Y14.5M.
2. This drawing is subject to change without notice.
3. This dimension does not include mold flash, protrusions, or gate burrs. Mold flash, protrusions, or gate burrs shall not exceed 0.15 mm per side.
4. This dimension does not include interlead flash. Interlead flash shall not exceed 0.25 mm per side.
5. Reference JEDEC registration MO-153.

EXAMPLE BOARD LAYOUT

PW0016A

TSSOP - 1.2 mm max height

SMALL OUTLINE PACKAGE



LAND PATTERN EXAMPLE
EXPOSED METAL SHOWN
SCALE: 10X



SOLDER MASK DETAILS

4220204/A 02/2017

NOTES: (continued)

- 6. Publication IPC-7351 may have alternate designs.
- 7. Solder mask tolerances between and around signal pads can vary based on board fabrication site.

EXAMPLE STENCIL DESIGN

PW0016A

TSSOP - 1.2 mm max height

SMALL OUTLINE PACKAGE



SOLDER PASTE EXAMPLE
BASED ON 0.125 mm THICK STENCIL
SCALE: 10X

4220204/A 02/2017

NOTES: (continued)

8. Laser cutting apertures with trapezoidal walls and rounded corners may offer better paste release. IPC-7525 may have alternate design recommendations.
9. Board assembly site may have different recommendations for stencil design.

IMPORTANT NOTICE AND DISCLAIMER

TI PROVIDES TECHNICAL AND RELIABILITY DATA (INCLUDING DATA SHEETS), DESIGN RESOURCES (INCLUDING REFERENCE DESIGNS), APPLICATION OR OTHER DESIGN ADVICE, WEB TOOLS, SAFETY INFORMATION, AND OTHER RESOURCES "AS IS" AND WITH ALL FAULTS, AND DISCLAIMS ALL WARRANTIES, EXPRESS AND IMPLIED, INCLUDING WITHOUT LIMITATION ANY IMPLIED WARRANTIES OF MERCHANTABILITY, FITNESS FOR A PARTICULAR PURPOSE OR NON-INFRINGEMENT OF THIRD PARTY INTELLECTUAL PROPERTY RIGHTS.

These resources are intended for skilled developers designing with TI products. You are solely responsible for (1) selecting the appropriate TI products for your application, (2) designing, validating and testing your application, and (3) ensuring your application meets applicable standards, and any other safety, security, regulatory or other requirements.

These resources are subject to change without notice. TI grants you permission to use these resources only for development of an application that uses the TI products described in the resource. Other reproduction and display of these resources is prohibited. No license is granted to any other TI intellectual property right or to any third party intellectual property right. TI disclaims responsibility for, and you will fully indemnify TI and its representatives against, any claims, damages, costs, losses, and liabilities arising out of your use of these resources.

TI's products are provided subject to [TI's Terms of Sale](#) or other applicable terms available either on ti.com or provided in conjunction with such TI products. TI's provision of these resources does not expand or otherwise alter TI's applicable warranties or warranty disclaimers for TI products.

TI objects to and rejects any additional or different terms you may have proposed.

Mailing Address: Texas Instruments, Post Office Box 655303, Dallas, Texas 75265
Copyright © 2022, Texas Instruments Incorporated