

General Description

The AP2815 is an integrated high-side power switch that consists of N-Channel MOSFET, charge pump, over current & temperature and other related protection circuits. The switch's low $R_{DS(ON)}$, 60m Ω , is designed to meet the USB voltage drop requirements. The IC integrates soft-start to limit inrush current, over-current protection, load short protection with fold-back, and thermal shutdown to avoid switch failure during hot plug-in. Under voltage lockout (UVLO) function is used to ensure the device remains off unless there is a valid input voltage present. A FLAG output is available to indicate fault conditions to the local USB controller.

The AP2815 is available in standard packages of SOIC-8 and MSOP-8.

Features

- Low MOSFET on Resistance: 60m Ω @ $V_{IN}=5.0V$
- Compliant to USB Specifications
- Operating Voltage Range: 2.7V to 5.5V
- Low Supply Current: 65 μA (Typ.)
- Low Shutdown Current: 1.0 μA (Max)
- Guarantee 1.5A Continuous Load
- Current Limit: 1.65A (Min), 2.8A (Max)
- Under-voltage Lockout
- Logic Level Enable Pin:
Available in Active-high or Active-low Version
- Soft Start-up
- Over-current Protection
- Over Temperature Protection
- Load Short Protection with Fold-back
- No Reverse Current when Power Off
- Deglitched FLAG Output with Open Drain
- With Output Shutdown Pull-low Resistor for A/C Versions
- UL Approved (File No. E339337)
- Nemko CB Scheme IEC60950-1, Ref. Certif No. NO64001

Applications

- USB Power Management
- USB Bus/Self Powered Hubs
- Hot-plug Power Supplies
- Battery-Charger circuits
- Notebook, Motherboard PCs

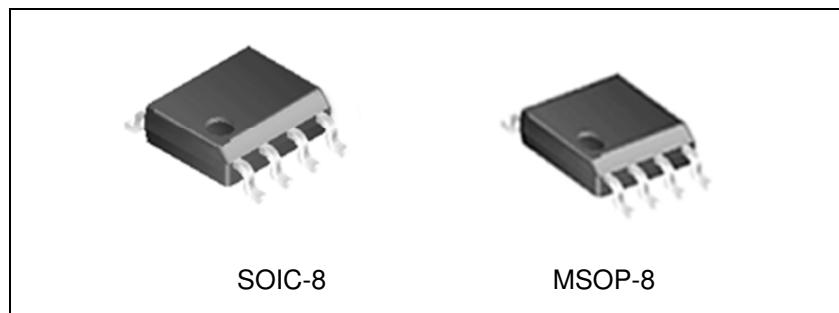

Figure 1. Package Types of AP2815

Pin Configuration

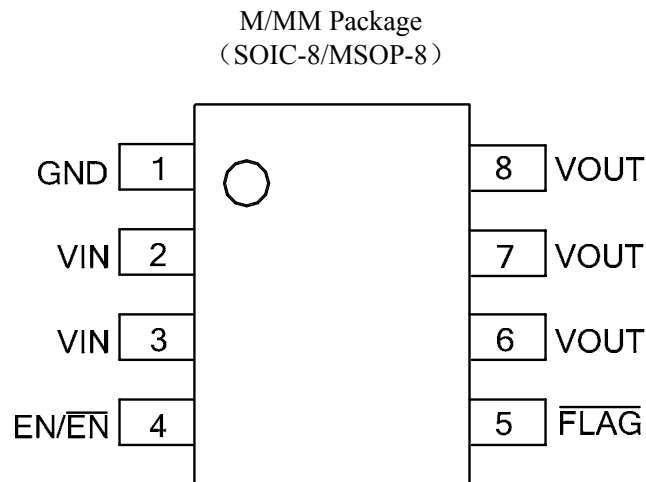

Figure 2. Pin Configuration of AP2815 (Top View)

Pin Descriptions

Pin No.	Name	Descriptions
1	GND	Ground
2, 3	VIN	Supply Input Pin
4	EN/ $\overline{\text{EN}}$	Chip Enable, Control Input, Active Low or High
5	$\overline{\text{FLAG}}$	Fault FLAG Pin, output with open drain, need a pull-up resistor in application, active low to indicate OCP or OTP.
6, 7, 8	VOUT	Output Voltage

Functional Block Diagram

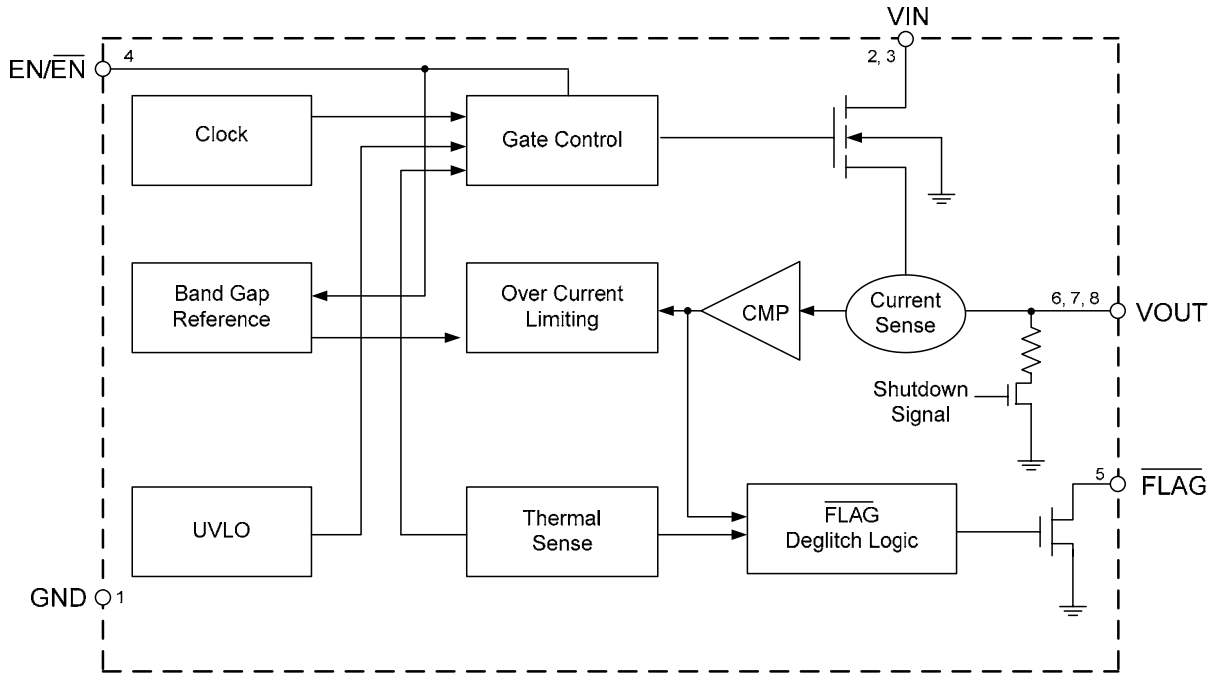

Figure 3. Functional Block Diagram of AP2815



1.5A High-side Power Distribution Switch with Enable and Flag

AP2815

Ordering Information

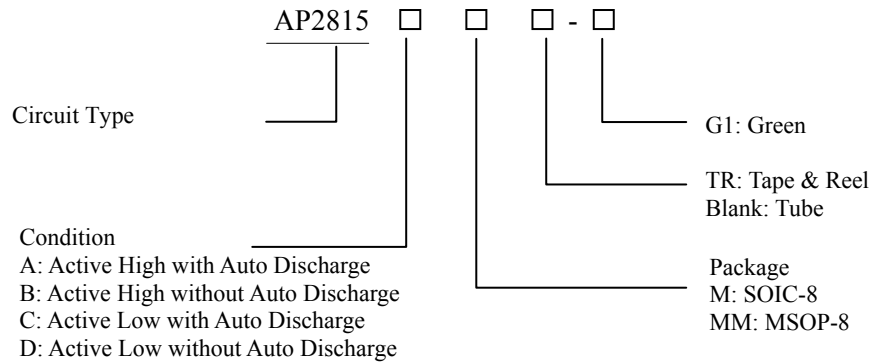

Product	Package	Temperature Range	Condition	Part Number	Marking ID	Packing Type
AP2815A	SOIC-8	-40 to 85°C	Active High with Auto Discharge	AP2815AM-G1	2815AM-G1	Tube
	MSOP-8			AP2815AMTR-G1	2815AM-G1	Tape & Reel
				AP2815AMM-G1	2815AMM-G1	Tube
				AP2815AMMTR-G1	2815AMM-G1	Tape & Reel
AP2815B	SOIC-8	-40 to 85°C	Active High without Auto Discharge	AP2815BM-G1	2815BM-G1	Tube
	MSOP-8			AP2815BMTR-G1	2815BM-G1	Tape & Reel
				AP2815BMM-G1	2815BMM-G1	Tube
				AP2815BMMTR-G1	2815BMM-G1	Tape & Reel
AP2815C	SOIC-8	-40 to 85°C	Active Low with Auto Discharge	AP2815CM-G1	2815CM-G1	Tube
	MSOP-8			AP2815CMTR-G1	2815CM-G1	Tape & Reel
				AP2815CMM-G1	2815CMM-G1	Tube
				AP2815CMMTR-G1	2815CMM-G1	Tape & Reel
AP2815D	SOIC-8	-40 to 85°C	Active Low without Auto Discharge	AP2815DM-G1	2815DM-G1	Tube
	MSOP-8			AP2815DMTR-G1	2815DM-G1	Tape & Reel
				AP2815DMM-G1	2815DMM-G1	Tube
				AP2815DMMTR-G1	2815DMM-G1	Tape & Reel

BCD Semiconductor's Pb-free products, as designated with "G1" suffix in the part number, are RoHS compliant and Green.

**1.5A High-side Power Distribution Switch with Enable and Flag****AP2815****Absolute Maximum Ratings (Note 1)**

Parameter	Symbol	Value	Unit	
Power Supply Voltage	V_{IN}	6.0	V	
Operating Junction Temperature Range	T_J	150	°C	
Storage Temperature Range	T_{STG}	-65 to 150	°C	
Lead Temperature (Soldering, 10sec)	T_{LEAD}	260	°C	
Thermal Resistance (Junction to Ambient)	θ_{JA}	SOIC-8	135	°C/W
		MSOP-8	150	
ESD (Machine Model)		200	V	
ESD (Human Body Model)		2000	V	

Note 1: Stresses greater than those listed under “Absolute Maximum Ratings” may cause permanent damage to the device. These are stress ratings only, and functional operation of the device at these or any other conditions beyond those indicated under “Recommended Operating Conditions” is not implied. Exposure to “Absolute Maximum Ratings” for extended periods may affect device reliability.

Recommended Operating Conditions

Parameter	Symbol	Min	Max	Unit
Supply Voltage	V_{IN}	2.7	5.5	V
Operating Ambient Temperature Range	T_A	-40	85	°C

**1.5A High-side Power Distribution Switch with Enable and Flag****AP2815****Electrical Characteristics**

($V_{IN}=5.0V$, $C_{IN}=2.2\mu F$, $C_{OUT}=1.0\mu F$, Typical $T_A = 25^\circ C$, **Bold** typeface applies over $-40^\circ C \leq T_A \leq 85^\circ C$ ranges, unless otherwise specified)

Parameter	Symbol	Test Conditions	Min	Typ	Max	Unit
Input Voltage Range	V_{IN}		2.7		5.5	V
Switch On Resistance	$R_{DS(ON)}$	$V_{IN}=5V$, $I_{OUT}=1.5A$		60	80	m Ω
Current Limit	I_{LIMIT}	$V_{OUT}=4.0V$	1.65	2.2	2.8	A
Supply Current	I_{SUPPLY}	$V_{IN}=5V$, R_{LOAD} Open		65	85	μA
Fold-back Short Current	I_{SHORT}	$V_{OUT}=0$		1.12		A
Shutdown Supply Current	$I_{SHUTDOWN}$	Chip Disable, Shutdown Mode		0.1	1	μA
Enable High Input Threshold	V_{ENH}		1.6		5.5	V
Enable Low Input Threshold	V_{ENL}		0		1.0	V
Enable pin Input Current	I_{EN}	Force 0 to 5.0V at EN Pin	-1.0		1.0	μA
Under Voltage Lockout threshold voltage	V_{UVLO}	V_{IN} Increasing from 0V	2.2	2.5	2.7	V
Under Voltage Hysteresis	V_{UVLOHY}			0.2		V
Reverse Current	$I_{REVERSE}$	Chip Disable, $V_{OUT} > V_{IN}$		0.1	1.0	μA
Output Pull Low Resistance after Shutdown	$R_{DISCHARGE}$	AP2815A, AP2815C only		13	50	Ω
Output Turn-on Time	t_{ON}	From Enable Active to 90% of output		500		μs
FLAG Pin Delay Time	t_{DFLG}	From Over Current Fault Condition to FLAG Active	5	10	15	ms
FLAG Pin Low Voltage	V_{FLG}	$I_{SINK}=5mA$		35	70	mV
FLAG Pin Leakage	$I_{LEAKAGE}$	FLAG Disable, Force 5.0V			1.0	μA
Thermal Shutdown Temperature	T_{OTSD}			150		$^\circ C$
Thermal Shutdown Hysteresis	T_{HYOTSD}			30		

Typical Performance Characteristics

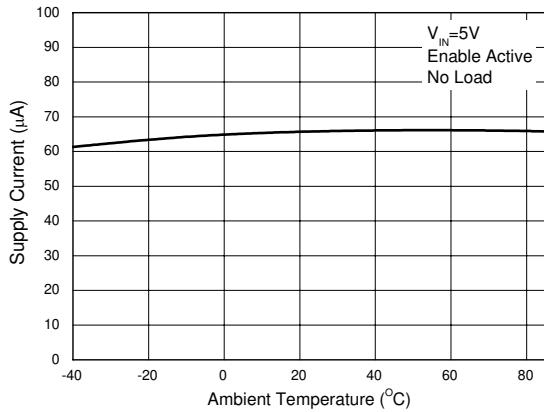

Figure 4. Supply Current vs. Ambient Temperature

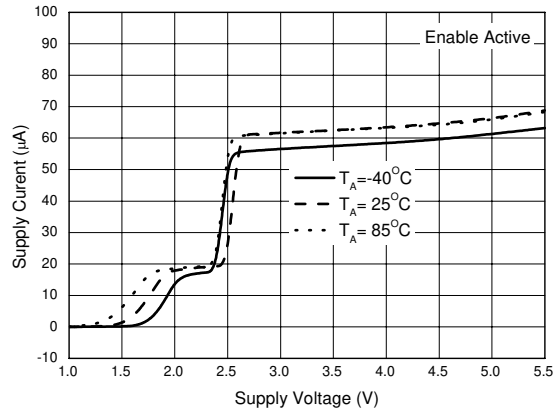

Figure 5. Supply Current vs. Supply Voltage

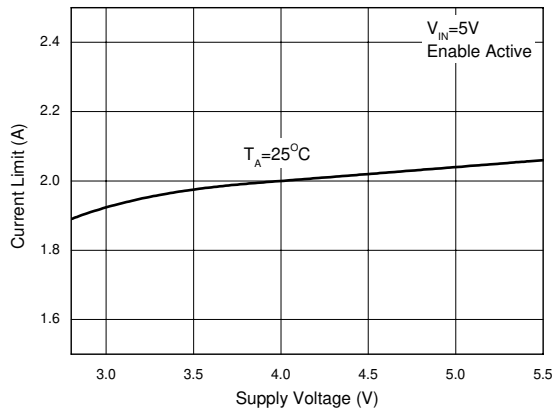

Figure 6. Current Limit vs. Supply Voltage

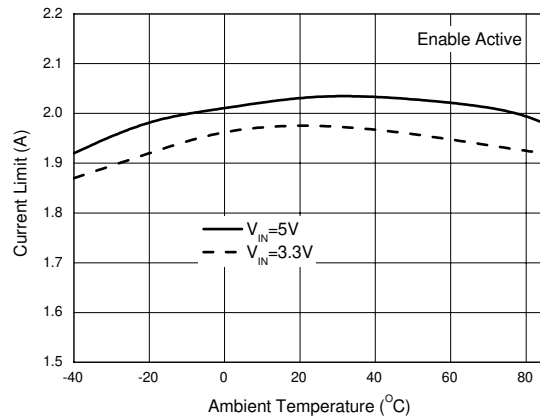

Figure 7. Current Limit vs. Ambient Temperature

Typical Performance Characteristics (Continued)

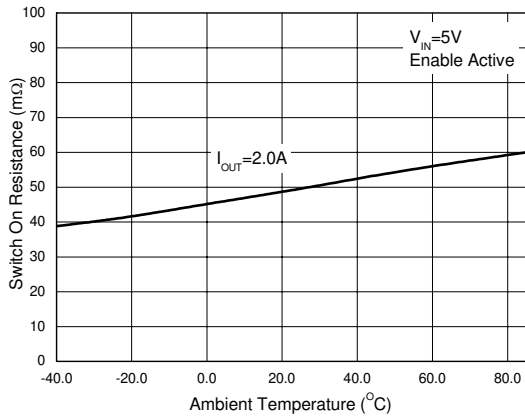

Figure 8. Switch On Resistance vs. Temperature

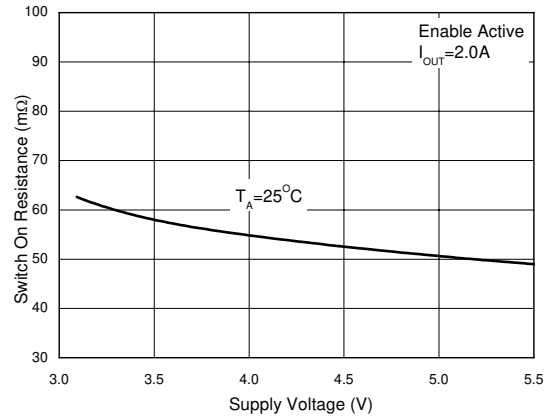

Figure 9. Switch On Resistance vs. Supply Voltage

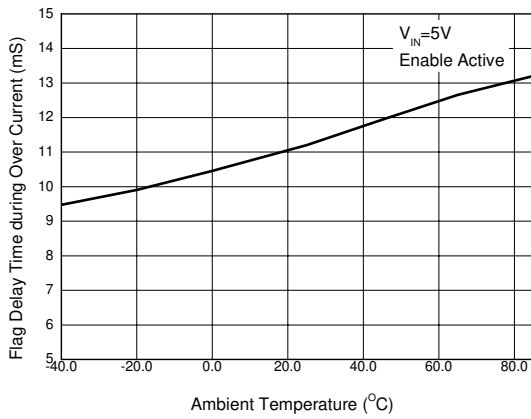

Figure 10. Flag Delay Time during Over Current vs. Ambient Temperature

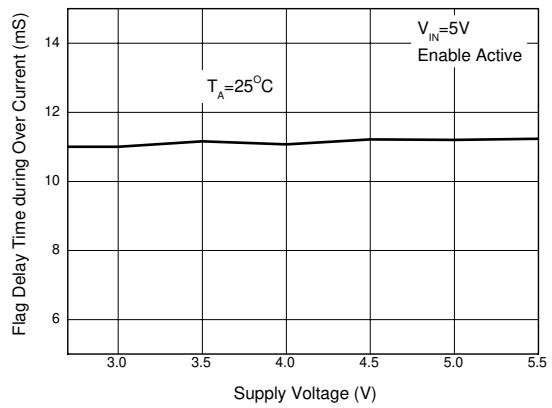

Figure 11. Flag Delay Time during Over Current vs. Supply Voltage

Typical Performance Characteristics (Continued)

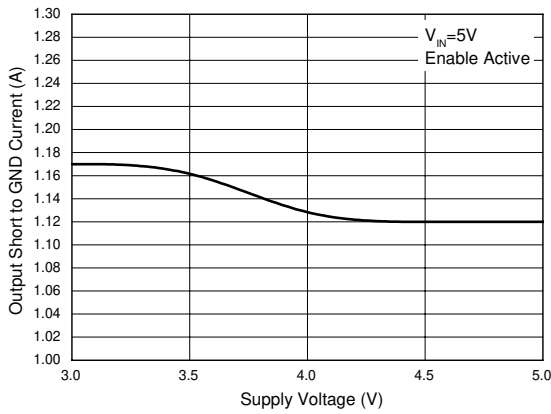

Figure 12. Output Short to GND Current vs. Supply Voltage

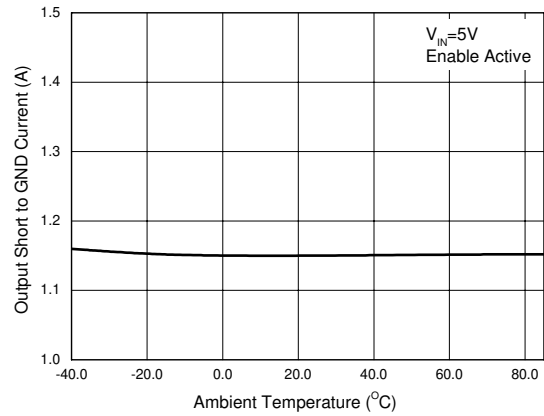

Figure 13. Output Short to GND Current vs. Ambient Temperature

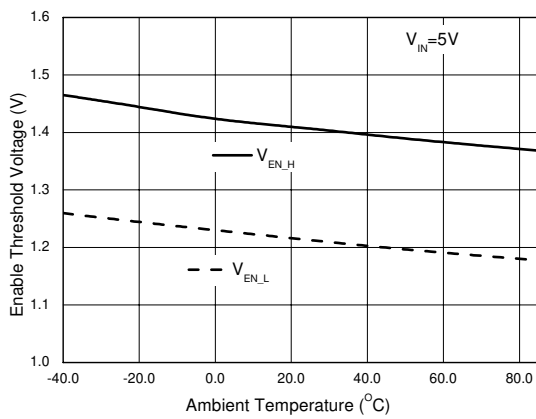

Figure 14. Enable Threshold Voltage vs. Ambient Temperature

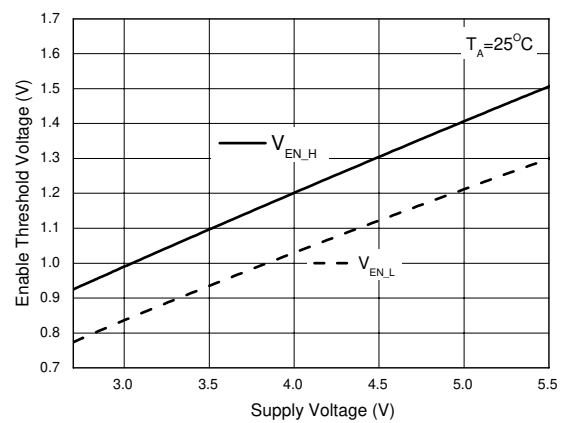

Figure 15. Enable Threshold Voltage vs. Supply Voltage

Typical Performance Characteristics (Continued)

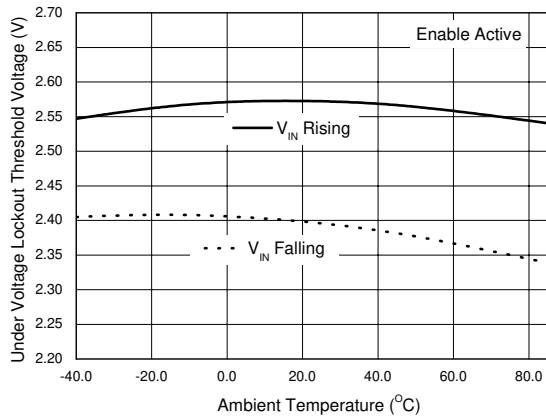

Figure 16. UVLO Voltage vs. Ambient Temperature

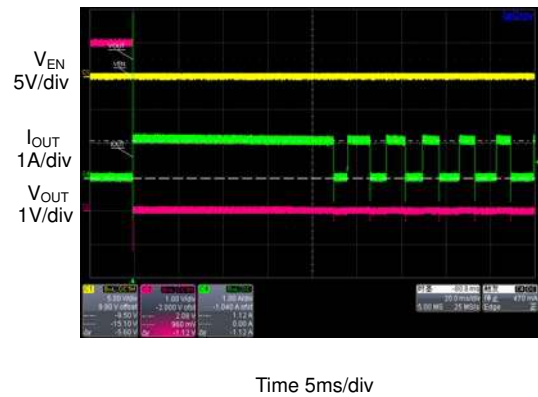

Figure 17. Output Short to GND Current ($V_{IN}=5V, C_{IN}=1.0\mu F$)

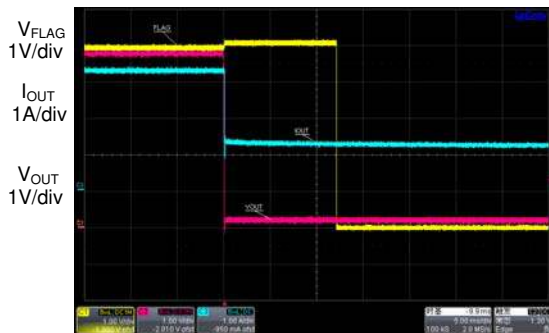

Figure 18. FLAG Response during Over Current



Figure 19. FLAG Response during Over Temperature ($T_A=125^\circ C$)

Typical Performance Characteristics (Continued)



Time 500µs/div

Figure 20. Output Turn On and Rise Time ($C_{IN}=1.0\mu F$, $C_{OUT}=1.0\mu F$, No Load)



Time 500µs/div

Figure 21. Output Turn On and Rise Time ($C_{IN}=1.0\mu F$, $C_{OUT}=1.0\mu F$, $R_L=3.3\Omega$)

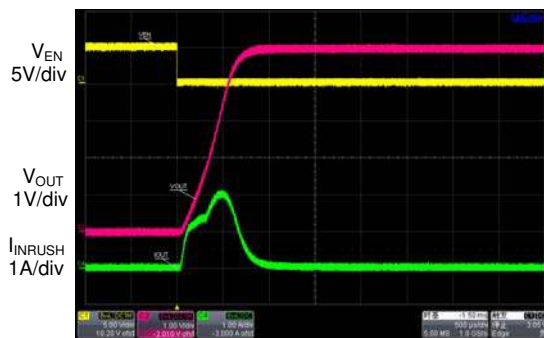

Time 500µs/div

Figure 22. Output Turn On and Rise Time ($C_{IN}=1.0\mu F$, $C_{OUT}=220\mu F$, No Load)

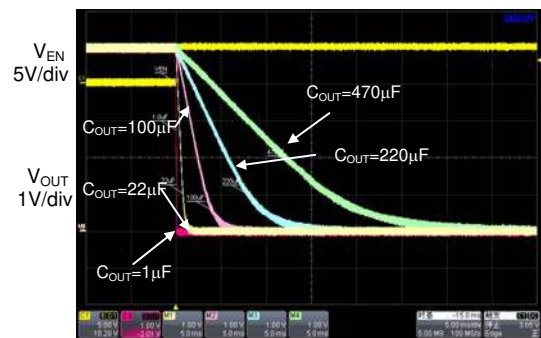

Time 5ms/div

Figure 23. Output Turn Off and Fall Time ($V_{IN}=5V$, $C_{IN}=1.0\mu F$, No Load)

Typical Performance Characteristics (Continued)

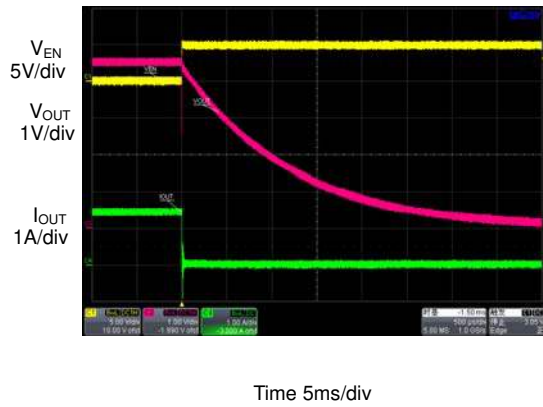
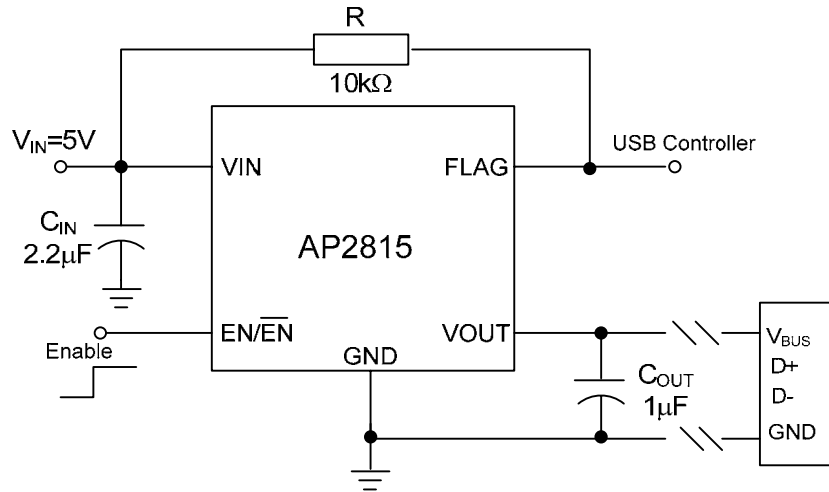

Figure 24. Output Turn Off and Fall Time
 ($V_{IN}=5V$, $C_{IN}=1.0\mu F$, $C_{OUT}=470\mu F$, $R_L=3.3\Omega$)

Typical Application



Note 2: $2.2\mu F$ input capacitor is enough in most application cases.

If the V_{OUT} is short to ground frequently during usage, large size input capacitor is necessary, recommend $22\mu F$.

Figure 25. Typical Application of AP2815

Mechanical Dimensions

SOIC-8

Unit: mm(inch)

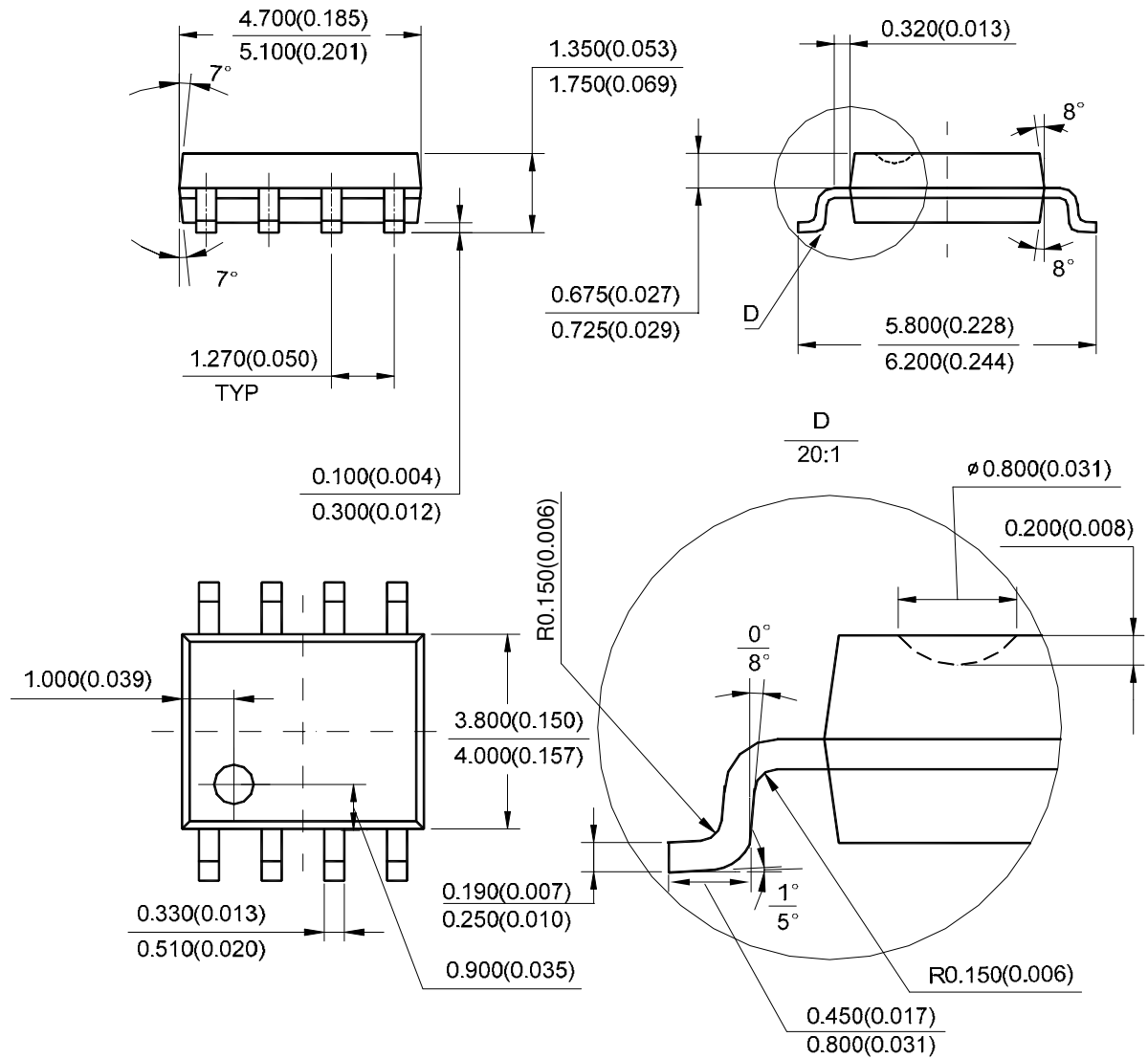

Note: Eject hole, oriented hole and mold mark is optional.

Mechanical Dimensions (Continued)

MSOP-8

Unit: mm(inch)

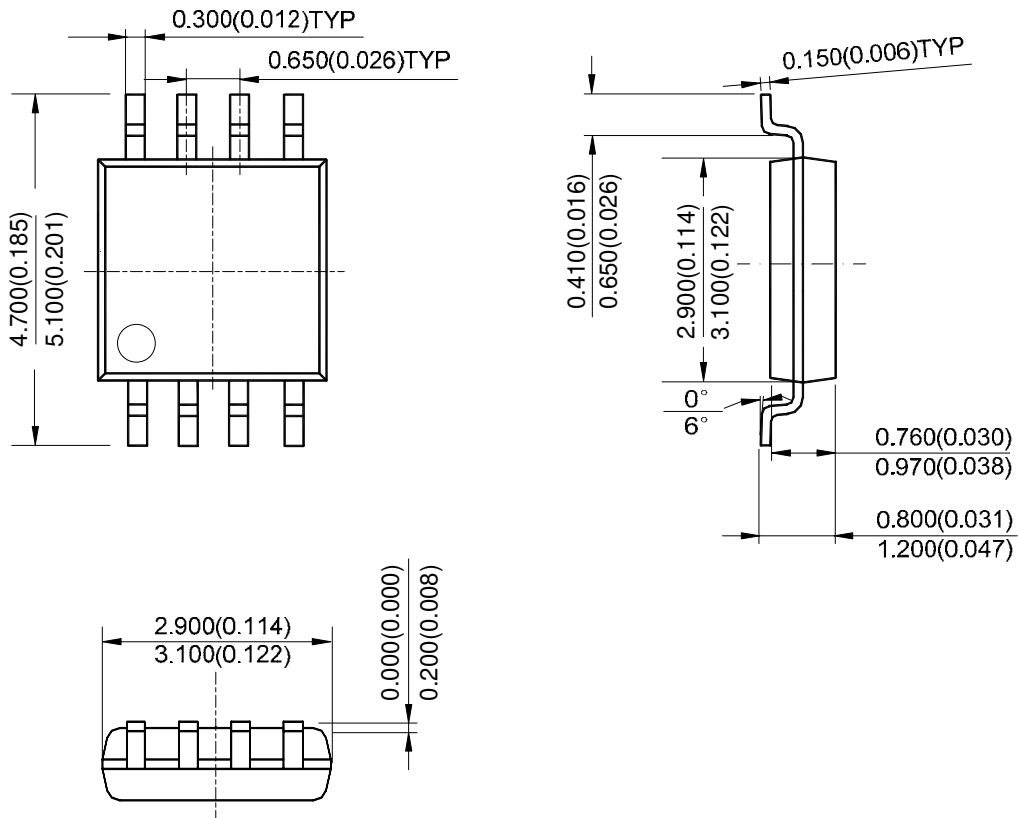

Note: Eject hole, oriented hole and mold mark is optional.



BCD Semiconductor Manufacturing Limited

<http://www.bcdsemi.com>

IMPORTANT NOTICE

BCD Semiconductor Manufacturing Limited reserves the right to make changes without further notice to any products or specifications herein. BCD Semiconductor Manufacturing Limited does not assume any responsibility for use of any its products for any particular purpose, nor does BCD Semiconductor Manufacturing Limited assume any liability arising out of the application or use of any its products or circuits. BCD Semiconductor Manufacturing Limited does not convey any license under its patent rights or other rights nor the rights of others.

MAIN SITE

- Headquarters

BCD Semiconductor Manufacturing Limited

No. 1600, Zi Xing Road, Shanghai Zizhu Science-based Industrial Park, 200241, China
Tel: +86-21-24162266, Fax: +86-21-24162277

- Wafer Fab

Shanghai SIM-BCD Semiconductor Manufacturing Co., Ltd.

800 Yi Shan Road, Shanghai 200233, China
Tel: +86-21-6485 1491, Fax: +86-21-5450 0008

REGIONAL SALES OFFICE

Shenzhen Office

Shanghai SIM-BCD Semiconductor Manufacturing Co., Ltd., Shenzhen Office

Unit A Room 1203, Skyworth Bldg., Gaoxin Ave. 1.S., Nanshan District, Shenzhen, China
Tel: +86-755-8826 7951
Fax: +86-755-8826 7865

Taiwan Office

BCD Semiconductor (Taiwan) Company Limited

4F, 298-1, Rui Guang Road, Nei-Hu District, Taipei, Taiwan
Tel: +886-2-2656 2808
Fax: +886-2-2656 2806

USA Office

BCD Semiconductor Corp.

30920 Huntwood Ave. Hayward, CA 94544, USA
Tel : +1-510-324-2988
Fax: +1-510-324-2788