

Product Specification

NHD-7.0-HDMI-HR-RSXP-xxx

TFT Liquid Crystal Display

NHD-	Newhaven Display
7.0-	7" Diagonal
HDMI-	HDMI Interface
HR-	1024 x 600 Resolution
RSXP-	IPS Display
xxx-	N/A - No Touch, CTU - Capacitive USB-HID

Table of Contents

Document Revision History	2
Functions and Features	2
Mechanical Drawing	3
Schematics	4
Electrical Characteristics	8
HDMI Receiver Information	8
Technical Resource	8
EDID Array	9
EDID Timing	9
Quality Information	10

Additional Resources

- **Support Forum:** <http://www.nhdforum.newhavendisplay.com>
- **GitHub:** <https://github.com/newhavendisplay>
- **Example Code:** https://www.newhavendisplay.com/example_code.html
- **Knowledge Center:** https://www.newhavendisplay.com/knowledge_center.html
- **Quality Center:** https://www.newhavendisplay.com/quality_center.html
- **Precautions for using LCDs/LCMs:** <https://www.newhavendisplay.com/specs/precautions.pdf>
- **Warranty / Terms & Conditions:** <https://www.newhavendisplay.com/terms.html>



Document Revision History

Revision	Date	Description	Changed By
0	04/22/2021	Initial Release	ZP

Functions and Features

- 7.0" HDMI TFT Module w/ USB-HID Capacitive option
- On-board Texas Instruments TFP401A HDMI/DVI Receiver
- HDMI (Type-A) Input
- Compatible with PC (Windows/Linux)
- Compatible with Linux based SBCs such as Raspberry Pi, BeagleBone, Windows Embedded etc.
- Plug-and-play USB-HID Touch, no external driver installation required
- 24-bit True Color, 1024x600 Resolution (SWVGA)
- On-board Texas Instruments TPS61165 High Brightness LED Driver w/ PWM
- IPS Panel, better color reproduction and full viewing angles
- 4 x 3.5mm Mounting Holes Enabling Standard M3 or #6-32 Screws
- Hardware sourced and Engineered in Elgin, IL (USA)

Mechanical Drawing

SYMBOL	REVISION	DATE

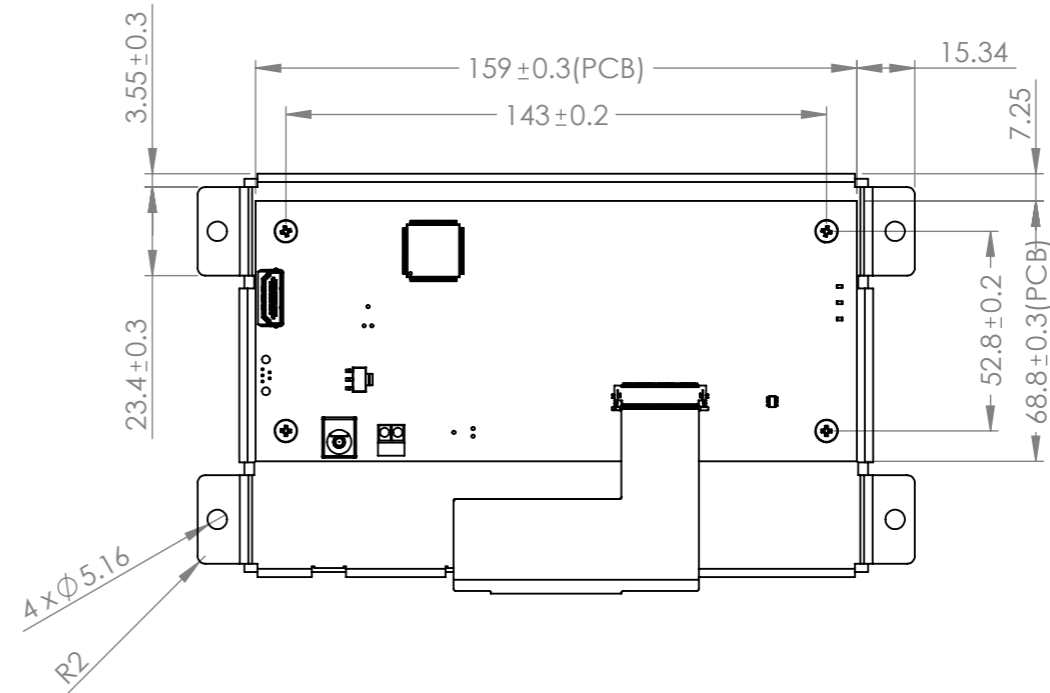
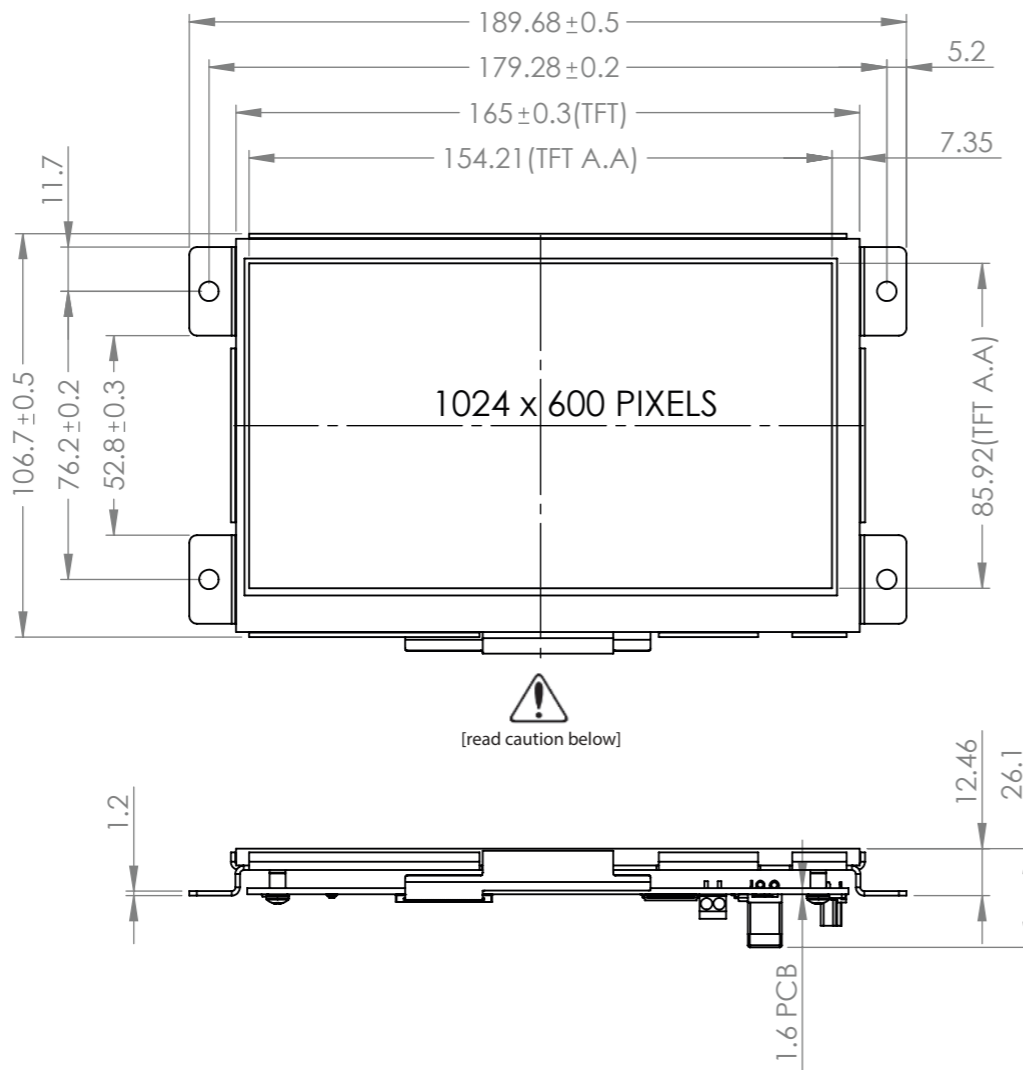

NOTES:

- 7.0" HDMI TFT Module
- On-board Texas Instruments TFP401A HDMI/DVI Receiver
- Optimal Viewing Direction: Full View (IPS)
- Display Mode: Transmissive / Normally White / Anti-Glare
- Brightness: 1100 cd/m² (Typ)
- 3M Brightness Enhancement Film
- On-board Texas Instruments TPS61165 High Brightness LED Driver w/ PWM
- 4x Mounting Holes, compatible with Rack Unit (RU) spacing

Improper handling of the FPC connection at the bottom edge of this module may cause damage resulting in display failure. Take special care when handling this area of the display module to make sure this connection is never strained nor creased.

STANDARD TOLERANCE: (UNLESS OTHERWISE SPECIFIED)		
LINEAR: $\pm 0.3\text{mm}$	DRAWING/PART NUMBER: NHD-7.0-HDMI-HR-RSXP	REVISION: -
UNLESS OTHERWISE SPECIFIED: - DIMENSIONS ARE IN MILLIMETERS - THIRD ANGLE PROJECTION	DRAWN BY: P. Bartek	APPROVED BY: M. LaVine
	DRAWN DATE: 05/29/19	APPROVED DATE: 05/31/19
	DO NOT SCALE DRAWING	
	SHEET 1 OF 1	
THIS DRAWING IS SOLELY THE PROPERTY OF NEWHAVEN DISPLAY INTERNATIONAL, INC. THE INFORMATION IT CONTAINS IS NOT TO BE DISCLOSED, REPRODUCED OR COPIED IN WHOLE OR PART WITHOUT WRITTEN APPROVAL FROM NEWHAVEN DISPLAY.		

TFP401 (DVI/HDMI Decoder)

LCD Interface

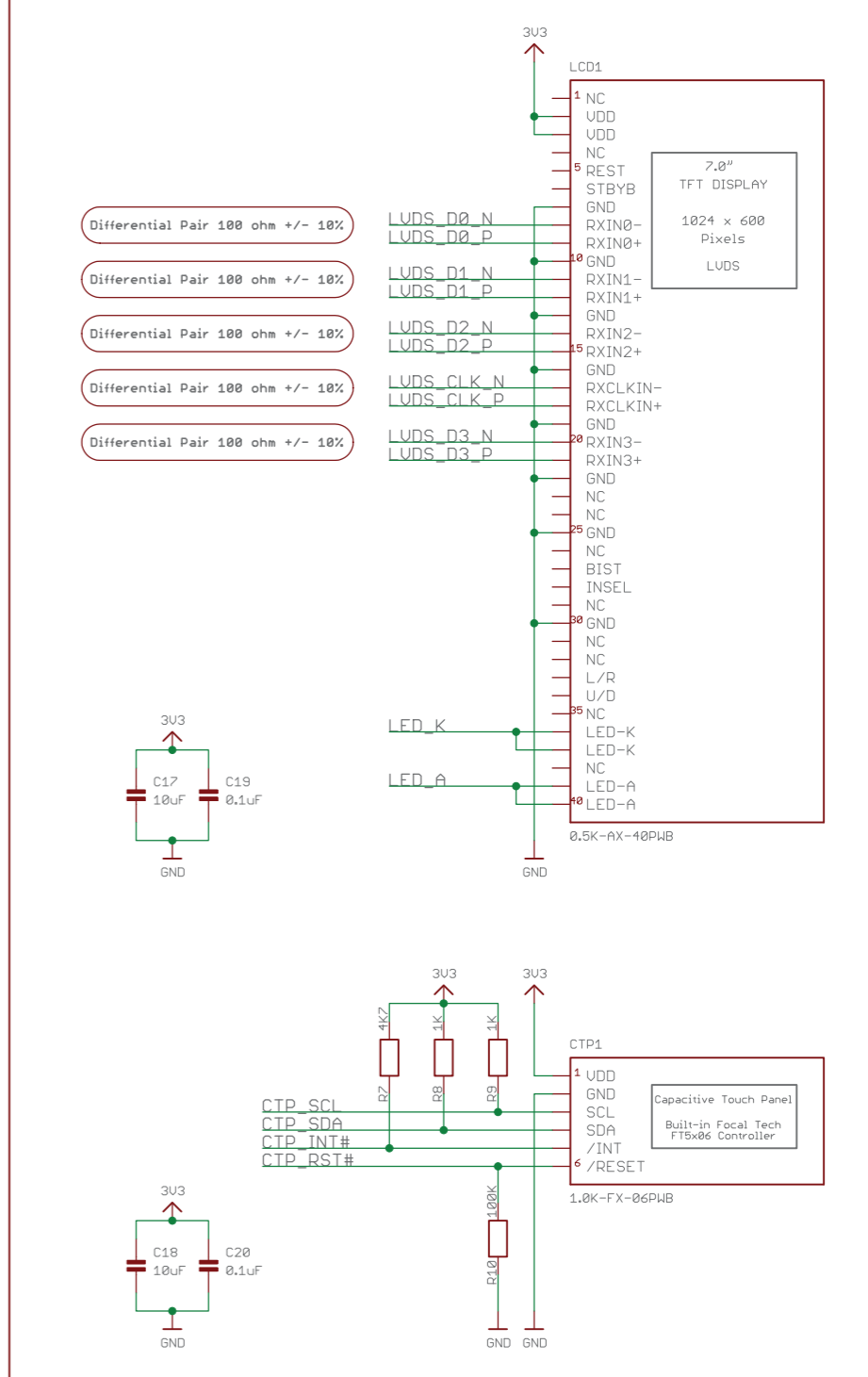
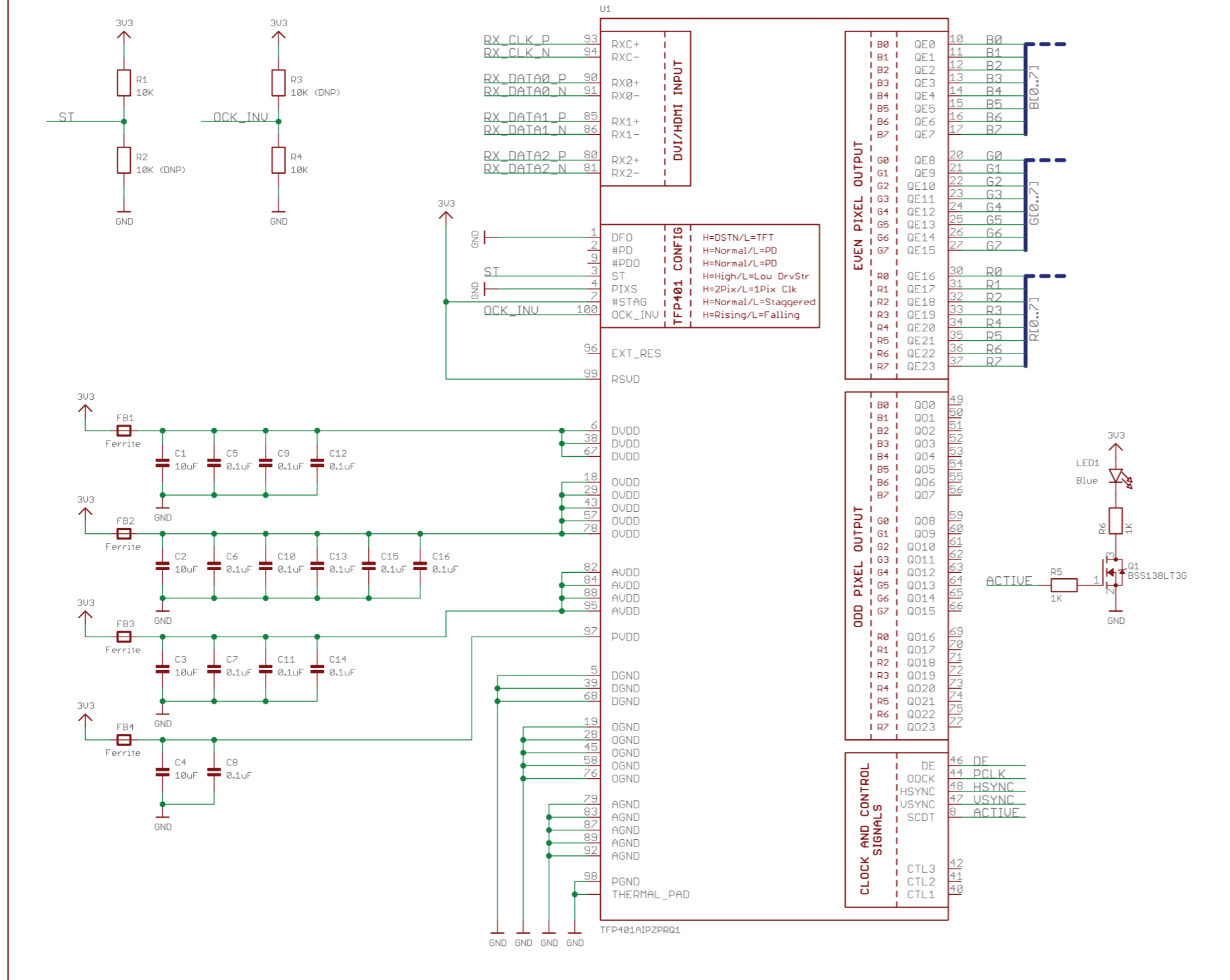

NEWHAVEN DISPLAY INTERNATIONAL

SCHEMATIC/PART NUMBER: **NHD-7.0-HDMI-HR_SCH**

REVISION: -

SIZE: A3

DRAWN BY: **P. Bartek** CHECKED BY: **M. LaVine**

DRAWN DATE: **05/31/19** CHECKED DATE: **05/31/19**

SHEET: 1 of 4

Released under the Creative Commons Attribution Share - Alike 4.0 License <http://creativecommons.org/licenses/by-sa/4.0>

open source hardware

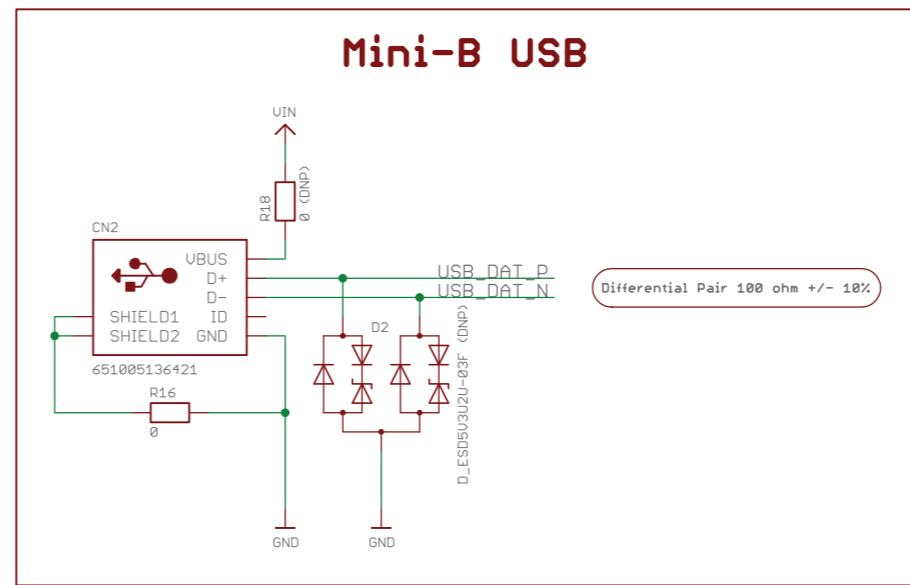
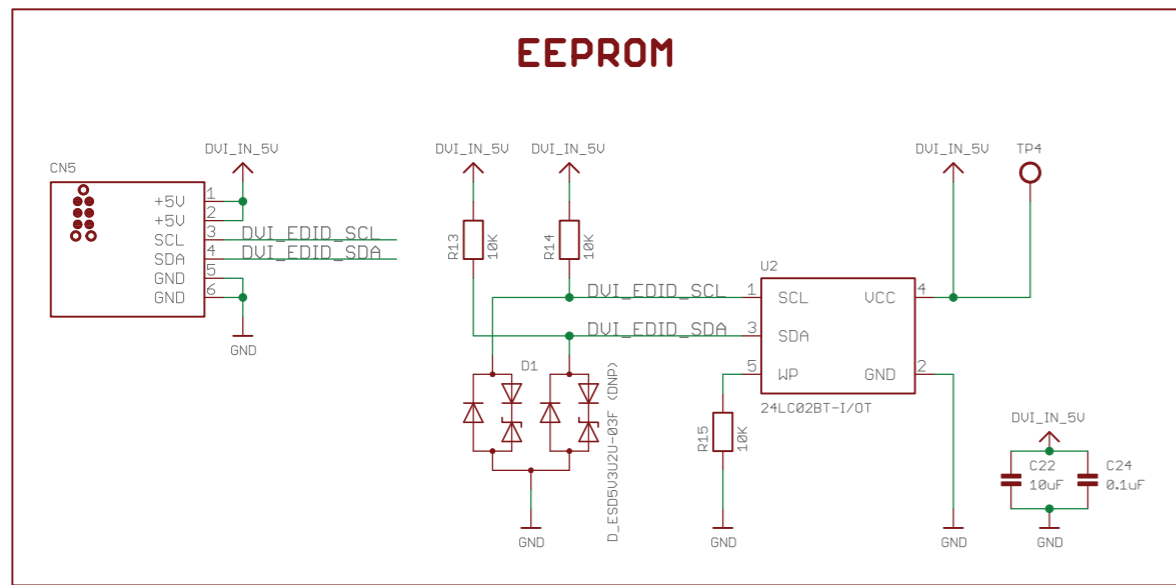
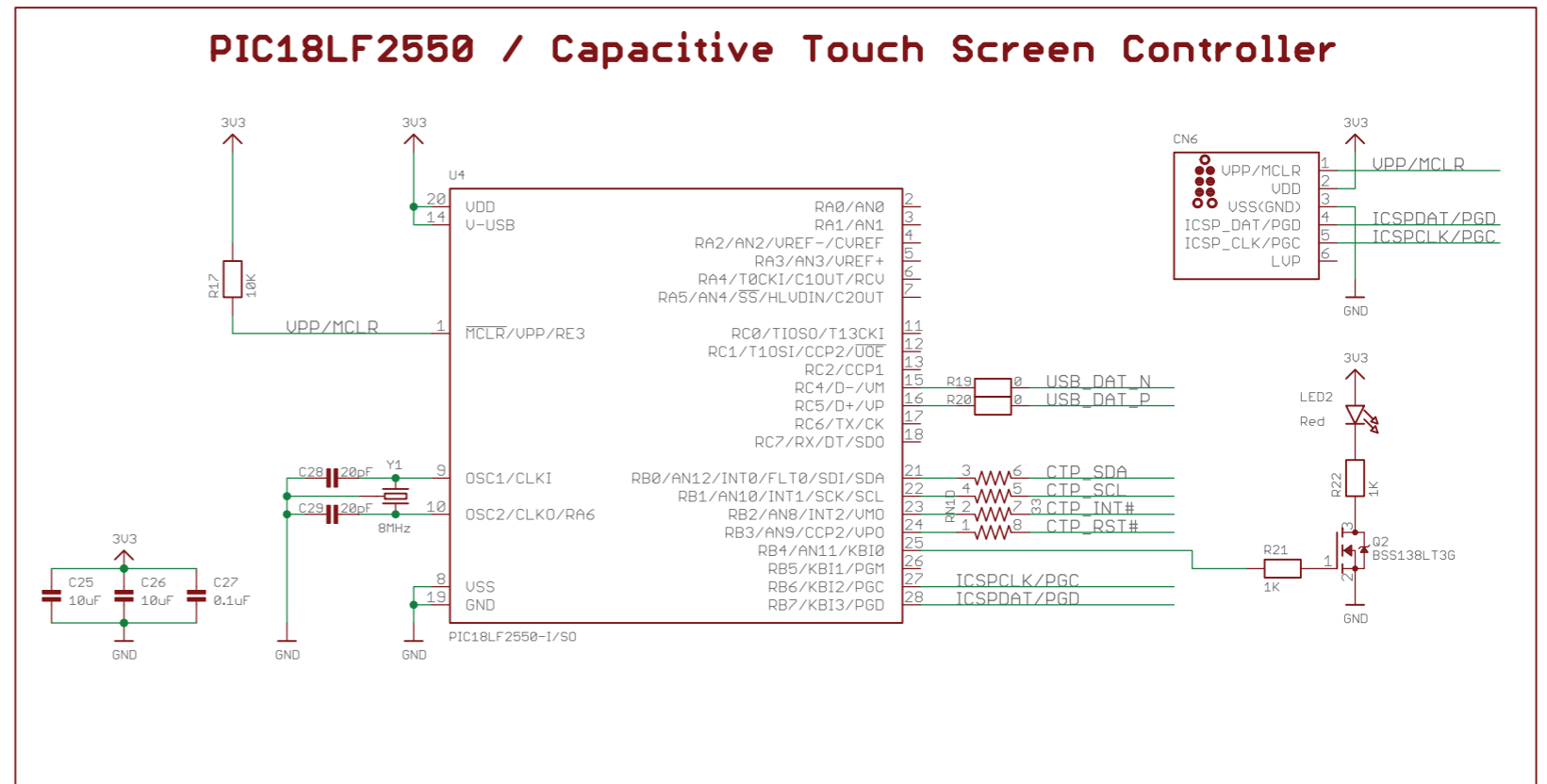
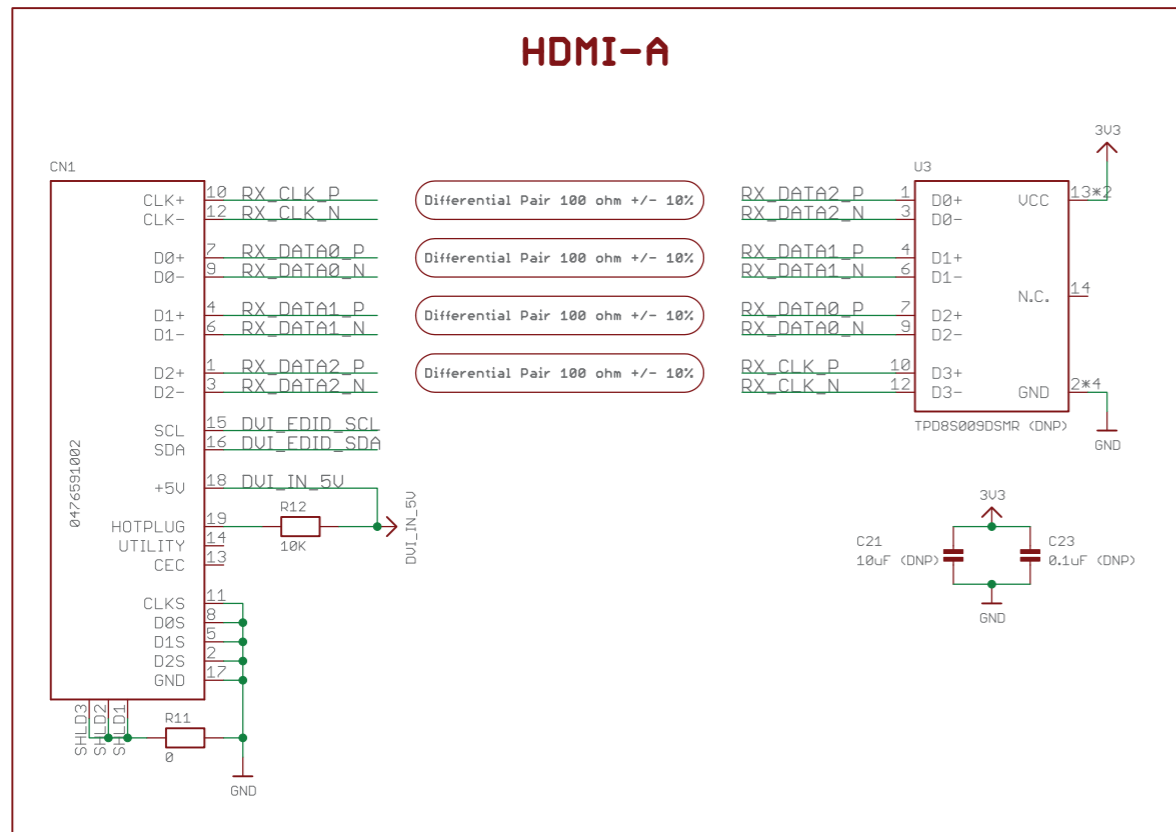

DS90C385A (LVDS Transmitter)

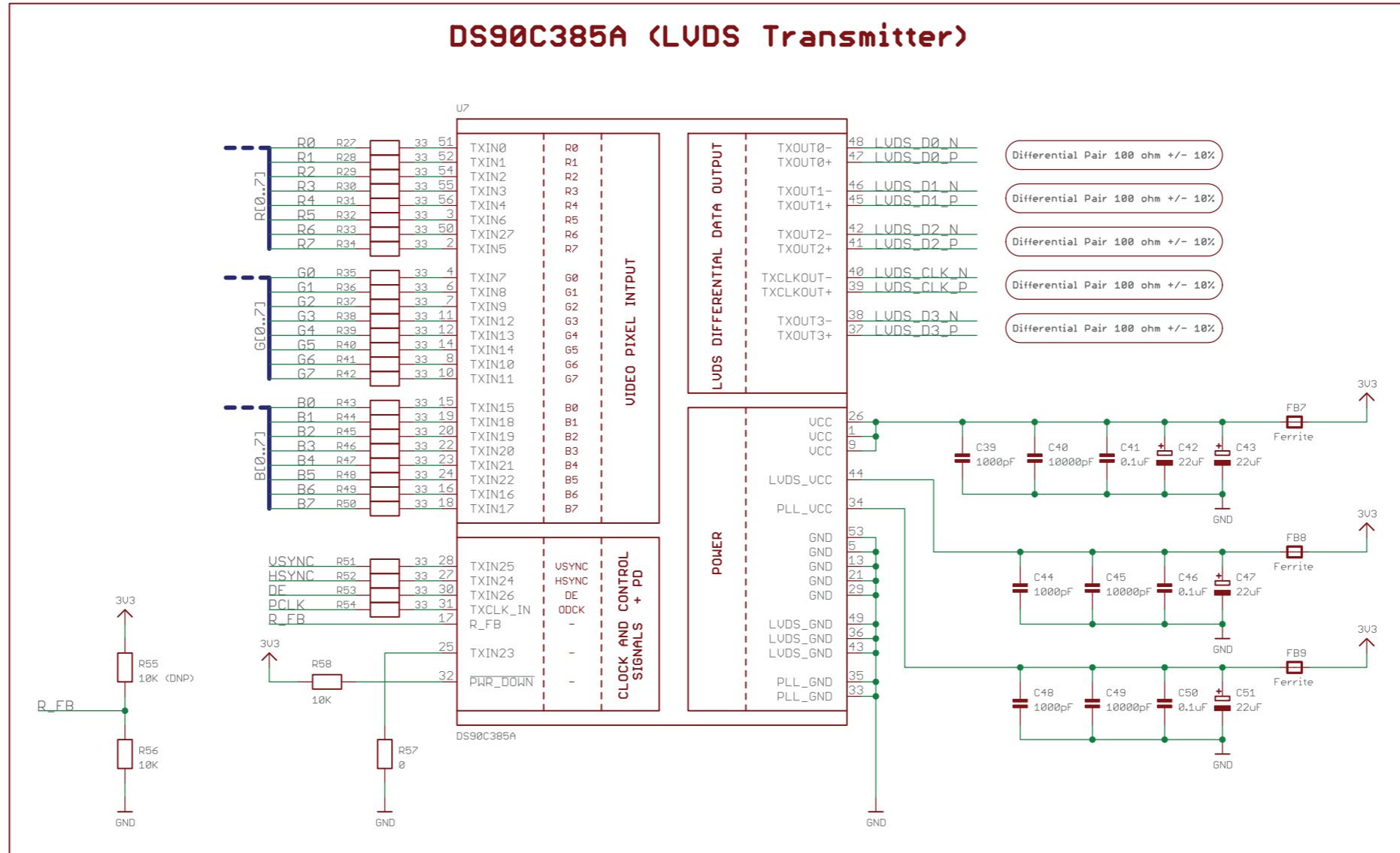

SCHEMATIC/PART NUMBER: NHD-7.0-HDMI-HR_SCH	
REVISION: -	
SIZE: A3	
DRAWN BY: P. Bartek	CHECKED BY: M. LaVine
DRAWN DATE: 05/31/19	CHECKED DATE: 05/31/19
SHEET: 2 of 4	
Released under the Creative Commons Attribution Share - Alike 4.0 License http://creativecommons.org/licenses/by-sa/4.0	

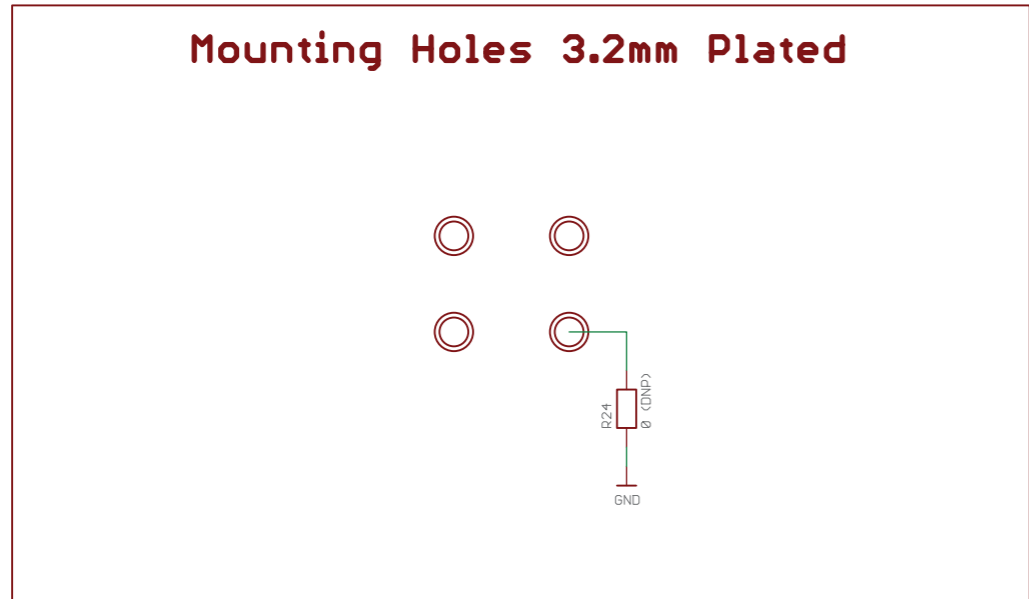
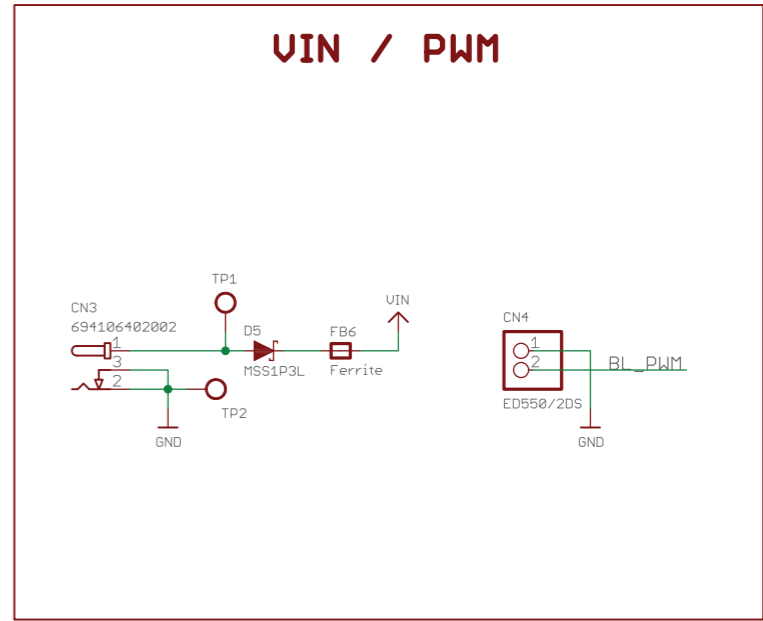
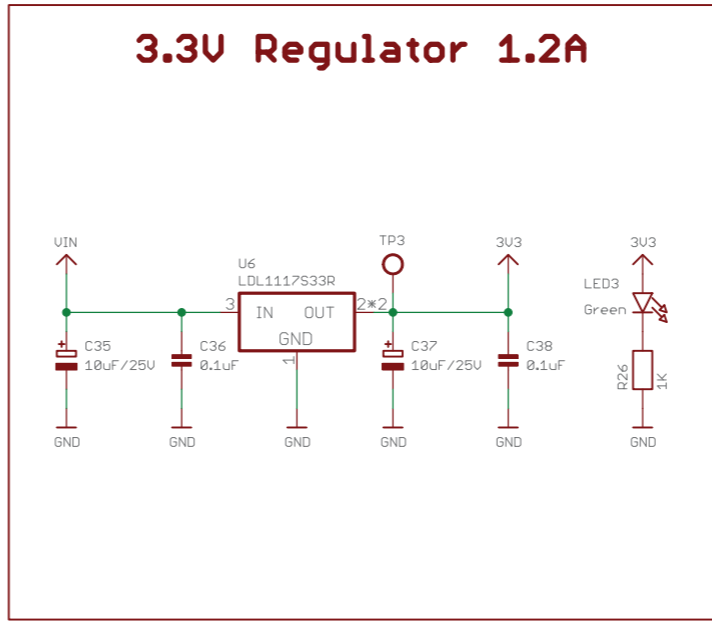
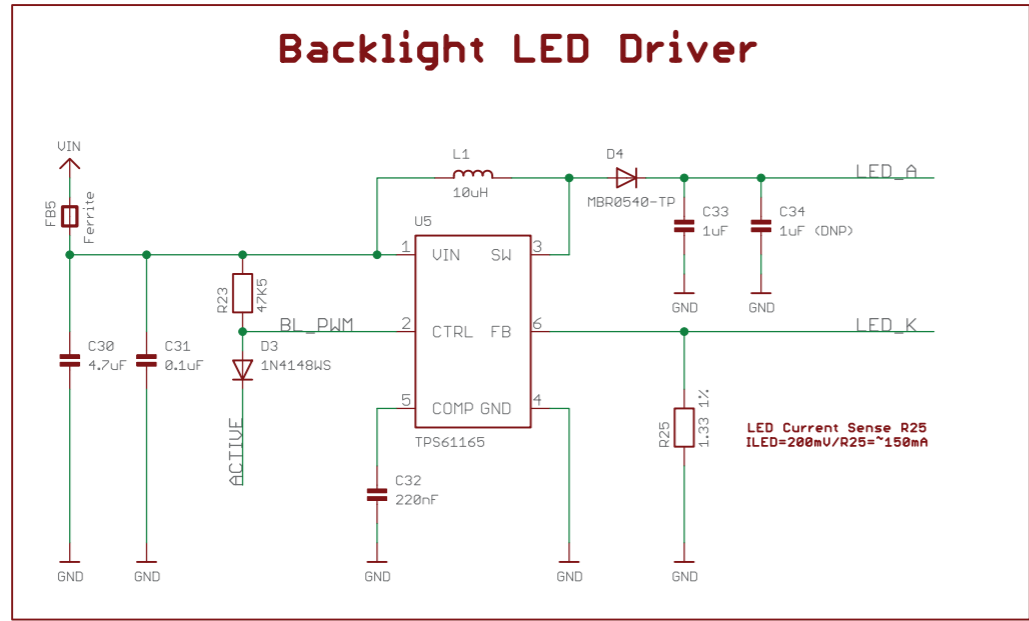

BOARD VERSIONS

CTU Version: (DNP) - C21, C23, C34, CN5, CN6, D1, D2, R2, R3, R55, R18, R24, U3

Non-Touch Version: (DNP) - C18, C21, C25, C26, C20, C23, C27, C28, C29, C34, CN2, CN5, CN6, CTP1, D1, D2, LED2, Q2, R2, R3, R17, R55, R7, R8, R9, R21, R22, R10, R16, R19, R20, R24, R18, RN1, U3, U4, Y1

SCHEMATIC / PART NUMBER: NHD-7.0-HDMI-HR_SCH	
REVISION: -	
SIZE: A3	
DRAWN BY: P. Bartek	CHECKED BY: M. LaVine
DRAWN DATE: 05/31/19	CHECKED DATE: 05/31/19
SHEET: 4 of 4	
Released under the Creative Commons Attribution Share - Alike 4.0 License http://creativecommons.org/licenses/by-sa/4.0	
open source hardware	

Electrical Characteristics

Item	Symbol	Condition	Min.	Typical	Max.	Unit
Operating Temperature Range	T _{OP}	Absolute Max	-20	-	+70	°C
Storage Temperature Range	T _{ST}	Absolute Max	-30	-	+80	°C
Backlight PWM Voltage	V _{PWM}	-	2.5	3.3	5.5	V
Backlight PWM Frequency	f _{PWM}	V _{PWM} = 3.3V	5	-	100	kHz
Module Supply Voltage	V _{DD}	-	5.0	-	7.0	V
Module Supply Current	I _{DD}	V _{DD} = 5V	-	1.2	1.5	A
		V _{DD} = 7V	-	0.9	1.2	A

HDMI Receiver Information

On-board Texas Instruments TFP401A Receiver. To view the full TFP401A specification, please download it by accessing the link: <http://www.ti.com/lit/ds/slids190a/slids190a.pdf>

Technical Resource

3D Model	TFT Panel Used	Display Type	Luminance Rating	Optimal Viewing Angle	Touch Panel
NHD-7.0-HDMI-HR-RSXP	NHD-7.0-1024600AF-LSXP	IPS, Sunlight Readable	1100 cd/m ²	85° all angles	No Touch
NHD-7.0-HDMI-HR-RSXP-CTU	NHD-7.0-1024600AF-LSXP-CTP	IPS, Sunlight Readable	900 cd/m ²	85° all angles	PCAP (USB-HID)

Quality Information

Test Item	Content of Test	Test Condition	Note
High Temperature storage	Endurance test applying the high storage temperature for a long time.	+80°C, 96 hrs.	2
Low Temperature storage	Endurance test applying the low storage temperature for a long time.	-30°C, 96 hrs.	1,2
High Temperature Operation	Endurance test applying the electric stress (voltage & current) and the high thermal stress for a long time.	+70°C, 96 hrs.	2
Low Temperature Operation	Endurance test applying the electric stress (voltage & current) and the low thermal stress for a long time.	-20°C, 96 hrs.	1,2
High Temperature / Humidity Operation	Endurance test applying the electric stress (voltage & current) and the high thermal with high humidity stress for a long time.	+60°C, 90% RH, 96 hrs.	1,2
Thermal Shock resistance	Endurance test applying the electric stress (voltage & current) during a cycle of low and high thermal stress.	-20°C, 30min->25°C, 5min -> 70°C, 30min = 1 Cycle 10 cycles	
Vibration test	Endurance test applying vibration to simulate transportation and use.	10-55Hz, 15mm amplitude. 60 sec in each of 3 directions X,Y,Z For 15 minutes	3
Static electricity test	Endurance test applying electric static discharge.	Air: $V_s = \pm 8KV$, Contact: $V_s = \pm 4KV$ 10 Times	

Note 1: No condensation to be observed.

Note 2: Conducted after 4 hours of storage at 25°C, 0%RH.

Note 3: Test performed on product itself, not inside a container.