

REVISIONS					
P	LTR	DESCRIPTION	DATE	DMN	APVD
M		REVISED PER ECO 20-005651	8-11-20	CT	DM

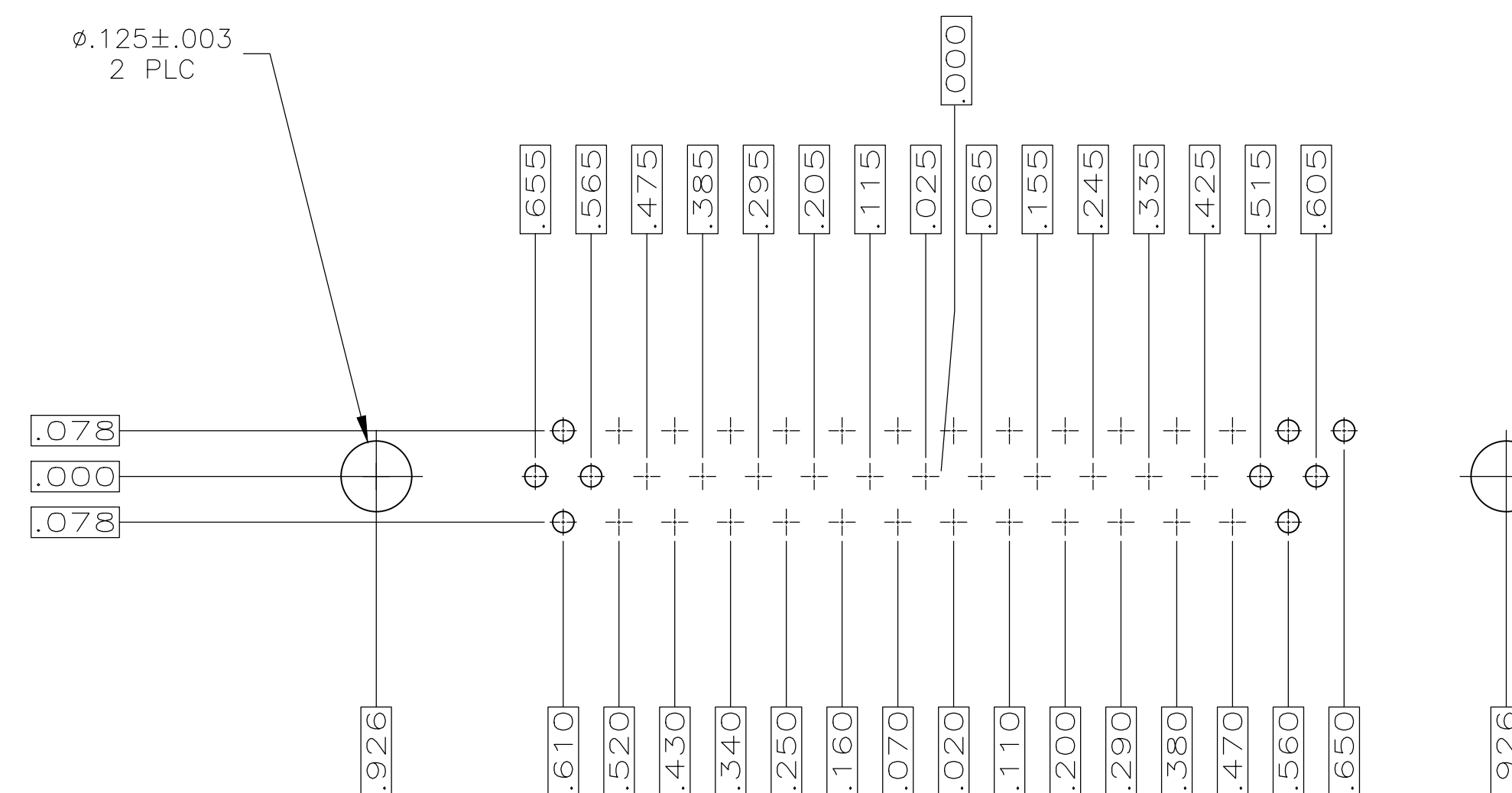

RECOMMENDED P.C. BOARD LAYOUT

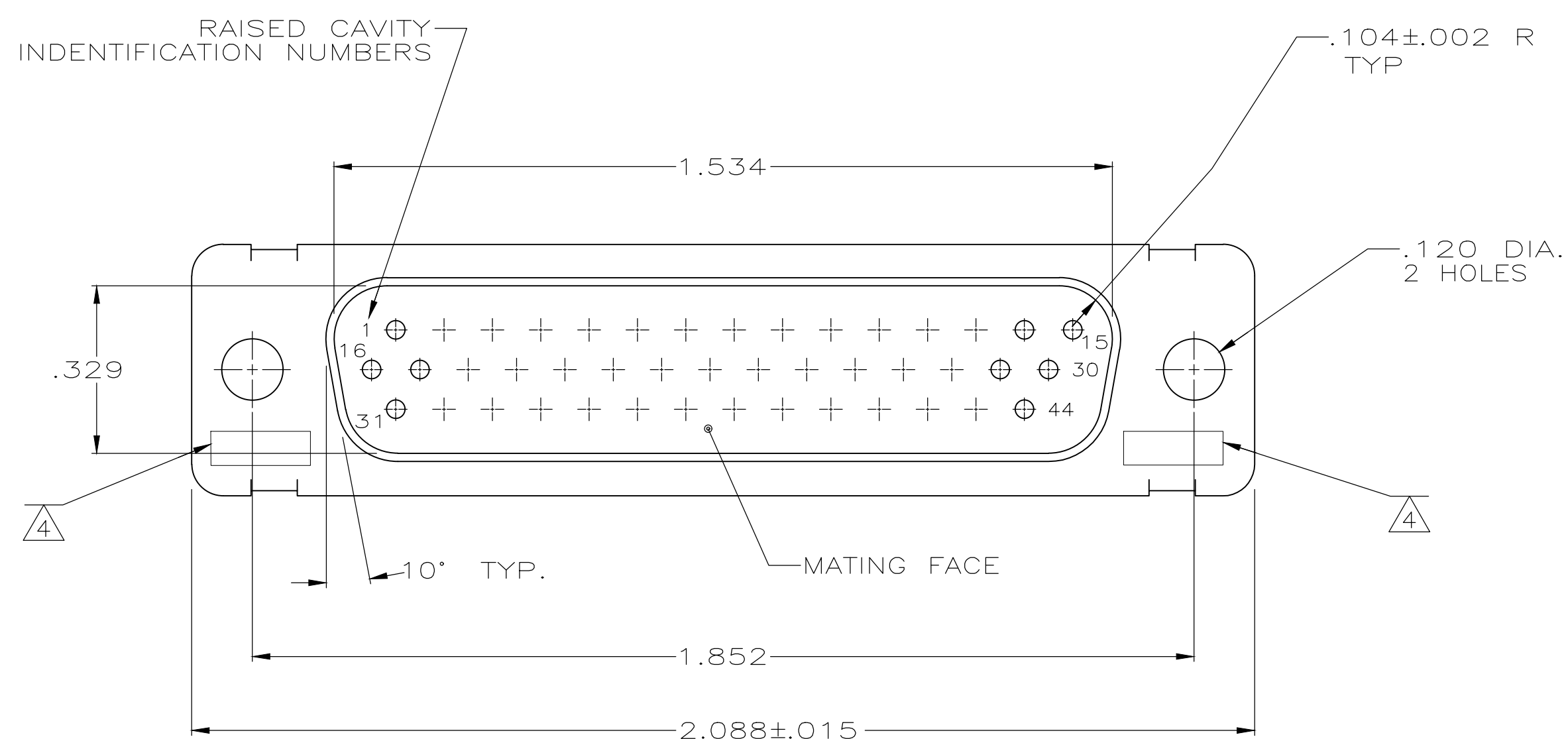
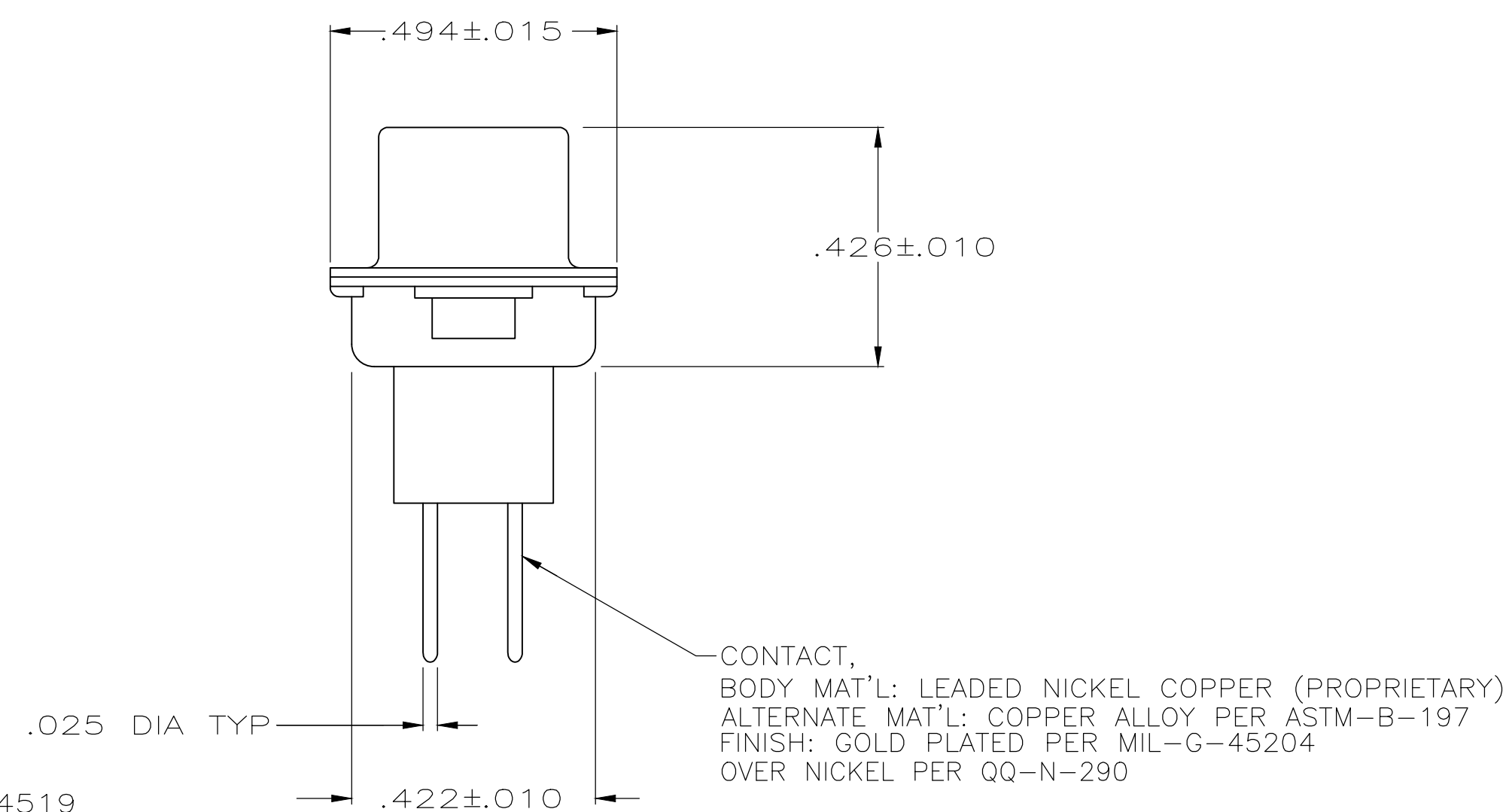
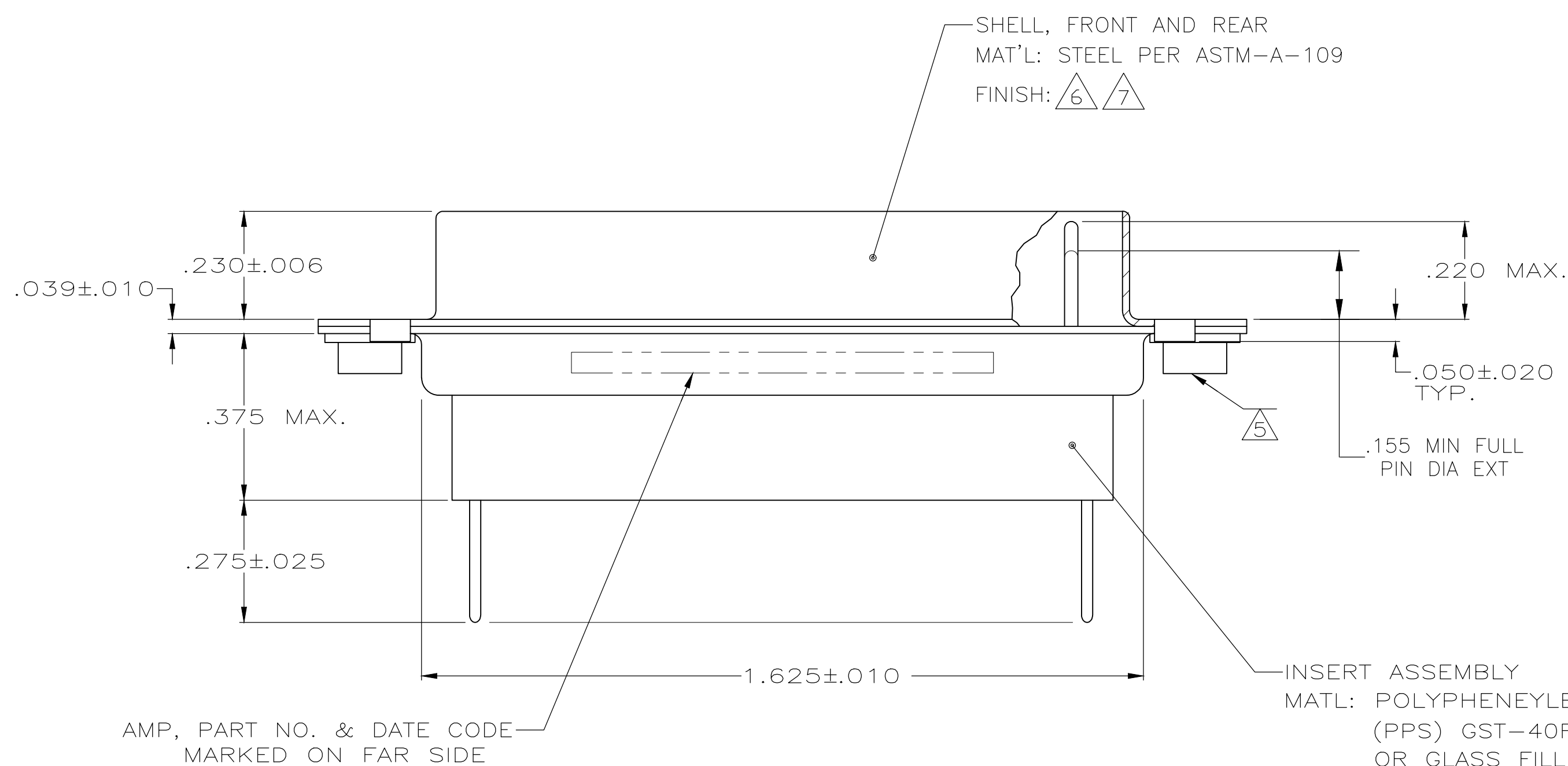

1. .040 DIA HOLE IS RECOMMENDED FOR P.C. BOARD
2. CONNECTOR MATES WITH ANY AMP 44 POSN RECEPTACLE
3. REPLACEMENT PIN AMP# 207683-8
4. UL/CSA DESIGNATION STAMPED IN THIS AREA.
5. CLINCH NUT(QTY = 2) IS USED ON 208868-3 ONLY.
6. FINISH: CADMIUM PER QQ-P-416
7. FINISH: ZINC PLATED PER ASTM-B-633, .000200-.000400 THK WITH SUPPLEMENTARY CHROMATE (Cr3+)

PLATED PER 7	5-208868-1
5, PLATED PER 6	208868-3
PLATED PER 6	208868-2
PLATED PER 6	208868-1
DESCRIPTION	PART NO.

THIS DRAWING IS A CONTROLLED DOCUMENT.		DIN C.C.THOMAS 1-7-88	
DIMENSIONS: INCHES		CHK F.C.BALLEW III 1-26-88	
TOLERANCES UNLESS OTHERWISE SPECIFIED:		APVD F.C.BALLEW III 1-26-88	
0 PLC ± .005		NAME	
1 PLC ± .005		AMP#	
2 PLC ± .005		PRODUCT SPEC	
3 PLC ± .005		APPLICATION SPEC	
4 PLC ± .005		SIZE	
ANGLES ± .005		CAGE CODE	
FINISH SEE CALLOUTS		DRAWING NO	
MATERIAL SEE CALLOUTS		WEIGHT 0.000000	
		A1 00779 C=208868	
		CUSTOMER DRAWING	
		SCALE 4:1 SHEET 1 OF 1 REV M	