

USED ON

DWG NO 1891771-1
 THIS DRAWING IS A CONTROLLED DOCUMENT FOR AMP INCORPORATED. IT IS SUBJECT TO CHANGE AND THE CONTROLLING ENGINEERING ORGANIZATION SHOULD BE CONTACTED FOR THE LATEST REVISION.

THIS INFORMATION IS CONFIDENTIAL AND IS DISCLOSED TO YOU ON CONDITION THAT NO FURTHER DISCLOSURE IS MADE BY YOU TO OTHER THAN AMP PERSONNEL WITHOUT WRITTEN AUTHORIZATION FROM AMP INCORPORATED, HARRISBURG, PA.

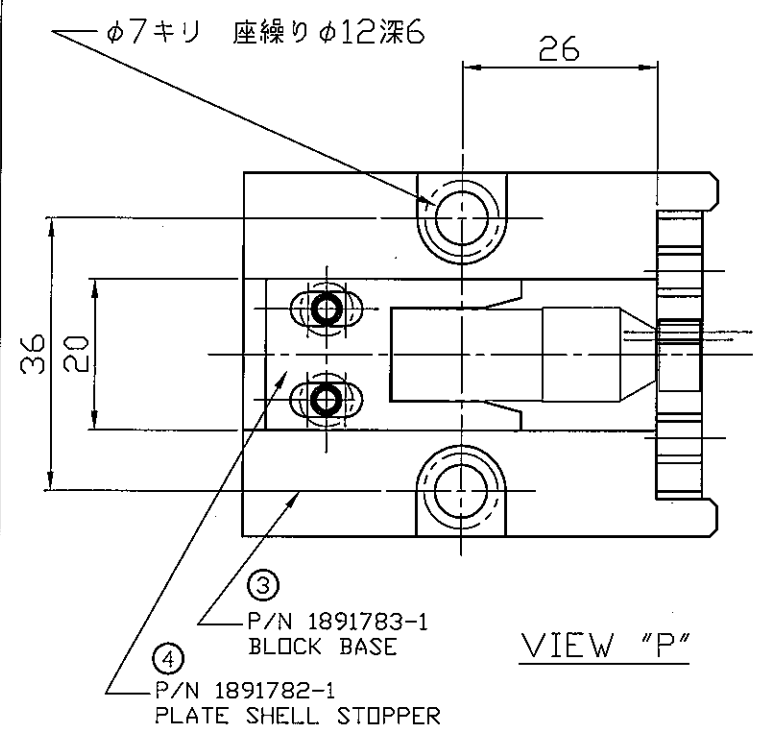

仕様 (Specifications)

- (1) 適用コネクタ : MECHATROLINK II CONNECTOR (APPLICABLE CONNECTOR)
- (2) 適用ワイヤー : HR2FV-SB AWG25×2芯 (大電製) (APPLICABLE WIRE) (HR2FV-SB AWG25×2C) (大電製)
- (3) 構成部品 (COMPONENT) :
 - ① P/N 1891769-1 CRIMPER SHELL 1ea
 - ② P/N 1891770-1 ANVIL SHELL 1ea
 - ③ P/N 1891783-1 BLOCK BASE 1ea
 - ④ P/N 1891782-1 PLATE SHELL STOPPER 1ea
- (4) 取扱説明書 : 411-78251 (CUSTOMER MANUAL)

注記 (NOTES)

- (1) 本部品は単体での使用は出来ません。別途プレスを用意して御使用下さい。(It is not possible to use it with this part alone.)
- (2) アンビル及びクリンパ取り付けの際は、上下の部品にズレが無い様に取り付けて下さい。(There must not be gap in upper and lower parts when you install ANVIL and CRIMPER.)
- (3) クリンプ高さを管理出来る様プレスには下死点を設けて下さい。(Thing to install descent edge stopper function in press)
- (4) クリンプ後の製品は114-5404で問題無きこと (The following Crimp product is a thing in 114-5404 without the problem.)

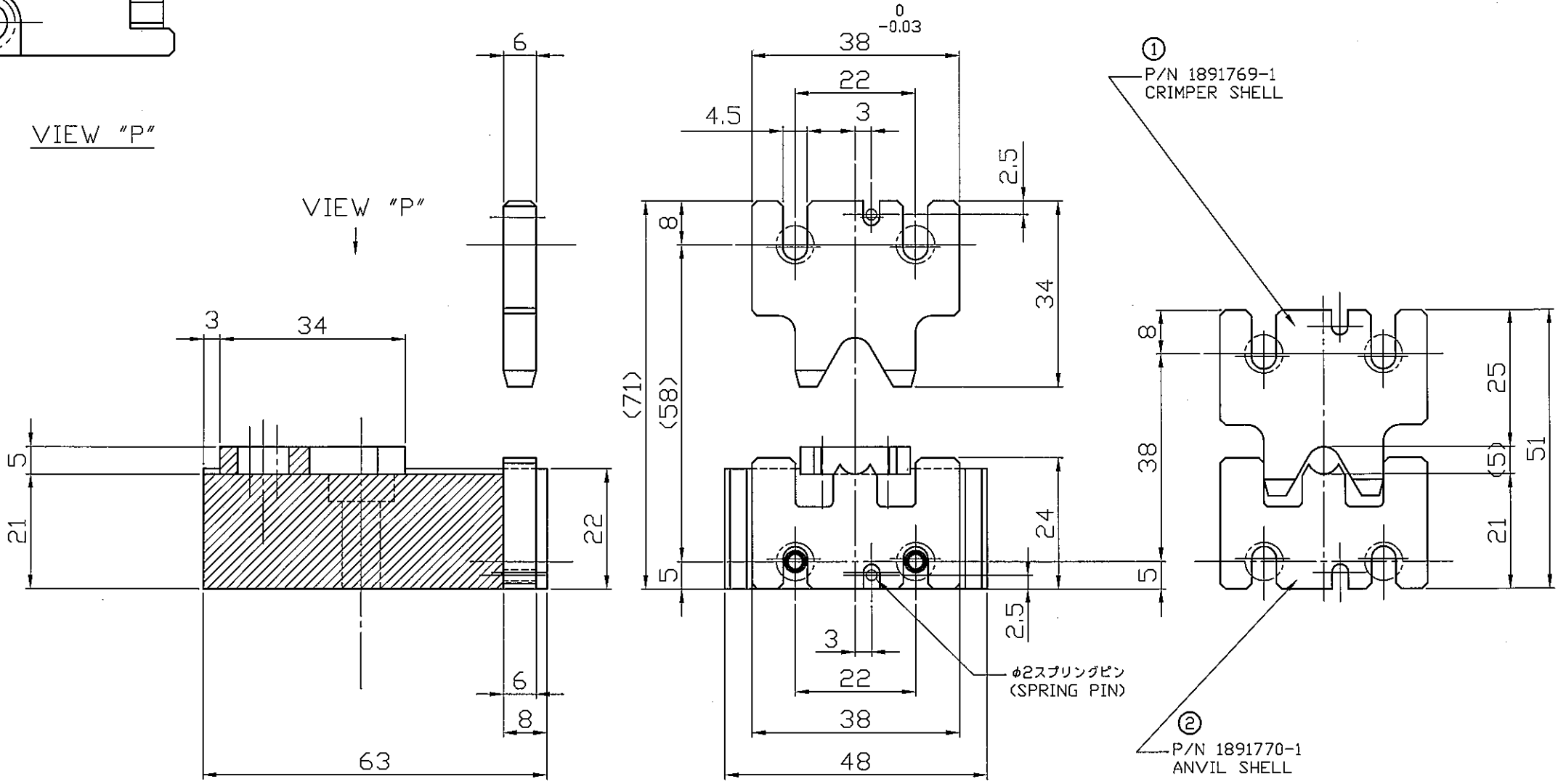

P	LTR	REVISION RECORD	DATE	DWN	APVD
B	REVISED		10 OCT 06	K.M	H.T
A	RELEASED		20 SEP 06	K.M	H.T

THIRD ANGLE PROJECTION.
 DIMENSIONS IN MILLIMETERS.
 DO NOT SCALE PRINT.
 TOLERANCES UNLESS OTHERWISE SPECIFIED.
 ANGLES ±0°30'
 UP TO 6 ±0.1 120 TO 315 ±0.5
 6 TO 30 ±0.2 315 TO 1000 ±0.8
 30 TO 120 ±0.3 OVER 1000 ±1.2
 REMOVE BURRS, BRAKE SHARP EDGES
 R0.4 MAX.

MATERIAL		HEAT TREAT		FINISH	
//		//		//	
DR 10 AUG 06 K.MARUYAMA	APP 10 AUG 06 H. TANAKA	Tyco Electronics AMP K.K. Kawasaki, Japan			
CHK 10 AUG 06 K.MARUYAMA	REL 10 AUG 06 H. TANAKA				
名称 (NAME) (DIES KIT SHELL) シェル ダイスキット					
SCALE	SIZE	DRAWING NO	SHEET	REV	
//	A3	1891771-1	1 OF 1	B	