

Description

The AS331 consists of a single precision voltage comparator with a typical input offset voltage of 1.0mV and high voltage gain. It is specifically designed to operate from a single power supply over wide range of voltages. Operation from split power supply is also possible and the low power supply current drain is independent of the magnitude of the power supply voltage.

The AS331 is available in the standard SOT25 package.

Pin Assignments

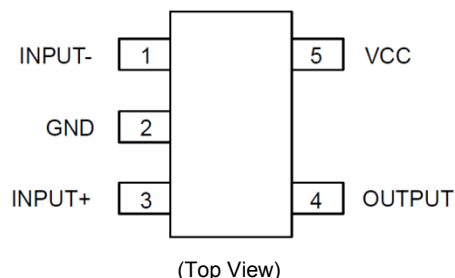

Features

- Wide Supply Voltage Range
 - Single Supply: 2V to 36V
 - Dual Supplies: $\pm 1V$ to $\pm 18V$
- Low Supply Current at VCC=5V: 0.4mA
- Low Input Bias Current: 25nA (Typical)
- Low Input Offset Current: 5nA (Typical)
- Low Input Offset Voltage: 1mV (Typical)
- Input Common Mode Voltage Range Includes Ground
- Differential Input Voltage Range Equals to the Power Supply Voltage
- Low Output Saturation Voltage at 4mA: 200mV (Typical)
- Open Collector Output
- **Totally Lead-Free & Fully RoHS Compliant (Notes 1 & 2)**
- **Halogen and Antimony Free. "Green" Device (Note 3)**
- **For automotive applications requiring specific change control (i.e. parts qualified to AEC-Q100/101/200, PPAP capable, and manufactured in IATF 16949 certified facilities), please [contact us](mailto:contact@diodes.com) or your local Diodes representative. <https://www.diodes.com/quality/product-definitions/>**

Applications

- Battery Chargers
- Cordless Telephones
- Switching Power Supplies
- DC-DC Modules
- PC Motherboards
- Communication Equipment

Notes:

1. No purposely added lead. Fully EU Directive 2002/95/EC (RoHS), 2011/65/EU (RoHS 2) & 2015/863/EU (RoHS 3) compliant.
2. See <https://www.diodes.com/quality/lead-free/> for more information about Diodes Incorporated's definitions of Halogen- and Antimony-free, "Green" and Lead-free.
3. Halogen- and Antimony-free "Green" products are defined as those which contain <900ppm bromine, <900ppm chlorine (<1500ppm total Br + Cl) and <1000ppm antimony compounds.

Typical Application

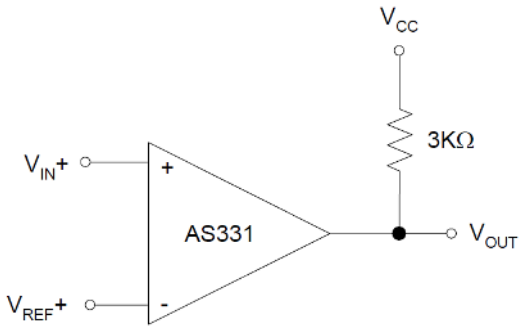

Basic Comparator

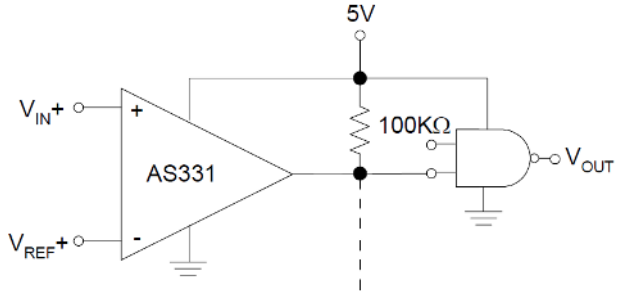

Driving CMOS

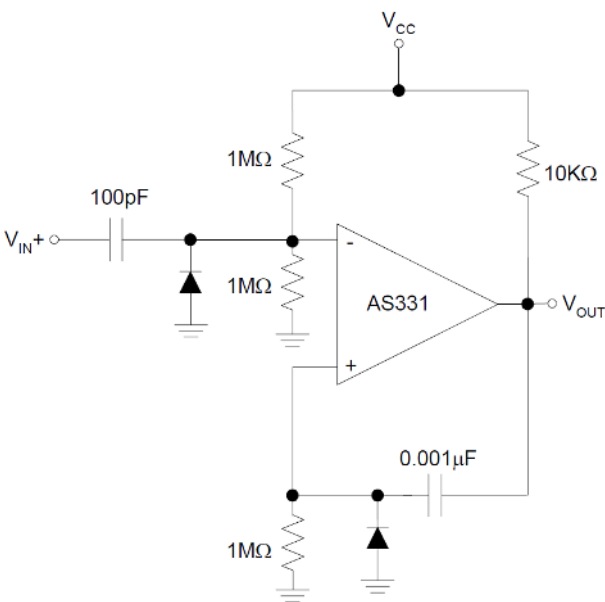

One Shot Multivibrator

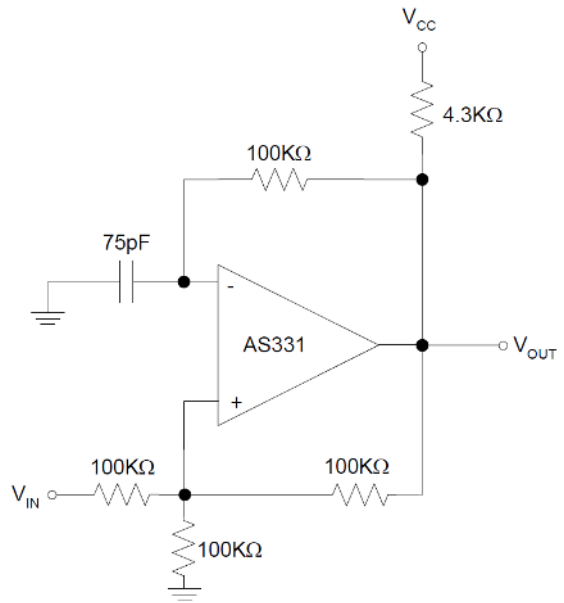

Squarewave Oscillator

Functional Block Diagram

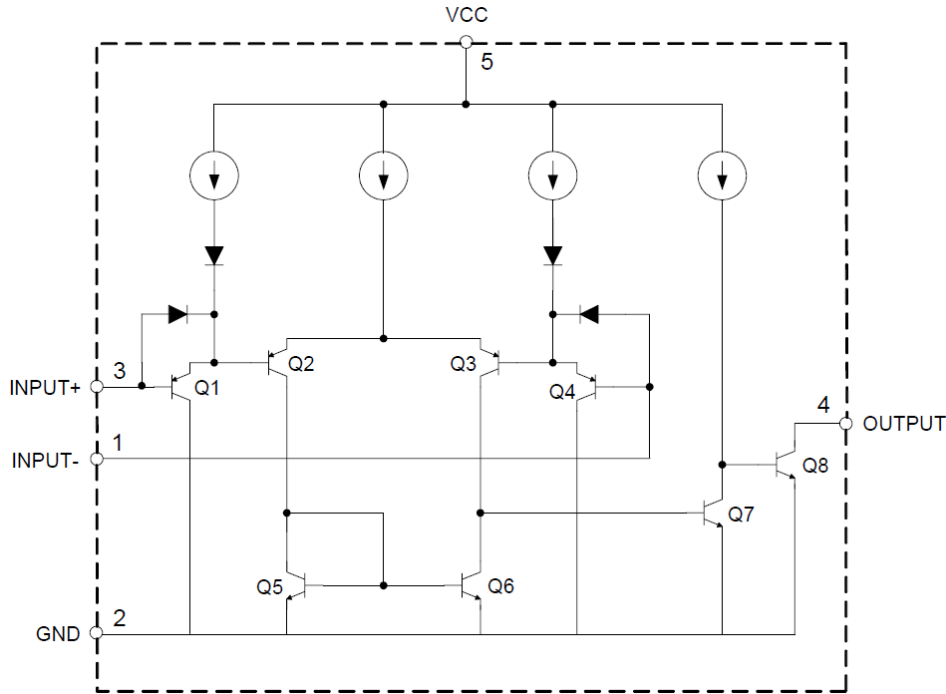

Absolute Maximum Ratings (@ $T_A = +25^\circ\text{C}$, unless otherwise specified.) (Note 4)

Parameter	Symbol	Value	Unit
Supply Voltage	V_{CC}	40	V
Differential Input Voltage	V_{ID}	40	V
Input Voltage	V_{IN}	-0.3 to 40	V
Input Current ($V_{IN} < -0.3\text{V}$) (Note 5)	I_{IN}	50	mA
Output Short-circuit Current to Ground	—	Continuous	—
Power Dissipation ($T_A = 25^\circ\text{C}$)	P_D	620	mW
Operating Junction Temperature	T_J	150	$^\circ\text{C}$
Storage Temperature	T_{STG}	-65 to 120	$^\circ\text{C}$
Lead Temperature (Soldering, 10sec)	T_{LEAD}	260	$^\circ\text{C}$

- Notes:
- Stresses greater than those listed under "Absolute Maximum Ratings" may cause permanent damage to the device. These are stress ratings only, and functional operation of the device at these or any other conditions beyond those indicated under "Recommended Operating Conditions" is not implied. Exposure to "Absolute Maximum Ratings" for extended periods may affect device reliability.
 - This input current will only exist when the voltage at any of the input leads is driven negative. It is due to the collector-base junction of the input PNP transistors becoming forward biased and thereby acting as input diode clamps. In addition to this diode action, there is also lateral NPN parasitic transistor action on the IC chip. This transistor action can cause the output voltages of the comparators to go to the V_+ voltage level (or to ground for a large overdrive) for the time duration that an input is driven negative. This is not destructive and normal output states will re-establish when the input voltage, which was negative, again returns to a value greater than -0.3V (at 25°C).

Recommended Operating Conditions (@ $T_A = +25^\circ\text{C}$, unless otherwise specified.)

Symbol	Parameter	Min	Max	Unit
V_{CC}	Supply Voltage	2	36	V
T_A	Operating Ambient Temperature Range	-40	85	$^\circ\text{C}$

Electrical Characteristics $V_{CC}=5V$, $GND=0V$, $T_A=25^\circ C$, unless otherwise specified. **Bold** typeface applies over $T_A=-40$ to $85^\circ C$ (Note 6)

Parameter	Symbol	Conditions	Min	Typ	Max	Unit	
Input Offset Voltage	V_{OS}	$V_{OUT}=1.4V$, $V_{CC}=5$ to $30V$	—	1	5	mV	
			—	—	7		
Input Bias Current	I_B	I_{IN+} or I_{IN-} with output in linear range, $V_{CM} = 0V$	—	25	250	nA	
			—	—	400		
Input Offset Current	I_{IO}	$I_{IN+}-I_{IN-}$, $V_{CM}=0V$	—	5	50	nA	
			—	—	200		
Input Common Mode Voltage Range (Note 7)	—	$V_{CC}=30V$	0	—	$V_{CC}-1.5$	V	
Supply Current	I_{CC}	$R_L=\infty$	$V_{CC}=5V$	—	0.4	1	mA
				—	—	2	
			$V_{CC}=30V$	—	0.5	1.7	
				—	—	3	
Voltage Gain	G_V	$V_{CC}=15V$, $R_L \geq 15k\Omega$, $V_{OUT}=1$ to $11V$	50	200	—	V/mV	
Large Signal Response Time	—	$V_{IN}=\text{TTL Logic Swing}$, $R_L=5.1k\Omega$	—	200	—	ns	
Response Time	—	$R_L=5.1k\Omega$	—	1.3	—	μA	
Output Sink Current	I_{SINK}	$V_{IN-}=1V$, $V_{IN+}=0V$, $V_{OUT}=1.5V$	6	16	—	mA	
Output Leakage Current	I_{LEAK}	$V_{IN-}=0V$, $V_{IN+}=1V$, $V_{OUT}=5V$	—	0.1	—	nA	
		$V_{IN-}=0V$, $V_{IN+}=1V$, $V_{OUT}=30V$	—	—	1	μA	
Saturation Voltage	V_{SAT}	$V_{IN-}=1V$, $V_{IN+}=0V$, $I_{SINK} \leq 4mA$	—	200	400	mV	
			—	—	500		

- Notes:
6. These specifications are limited to $-40^\circ C \leq T_A \leq 85^\circ C$. Limits over temperature are guaranteed by design, but not tested in production.
 7. The input common mode voltage of either input signal voltage should not be allowed to go negatively by more than 0.3V (at $25^\circ C$). The upper end of the common mode voltage range is $V_{CC}-1.5V$ (at $25^\circ C$), but either or both inputs can go to +36V without damages, independent of the magnitude of the V_{CC} .

Performance Characteristics

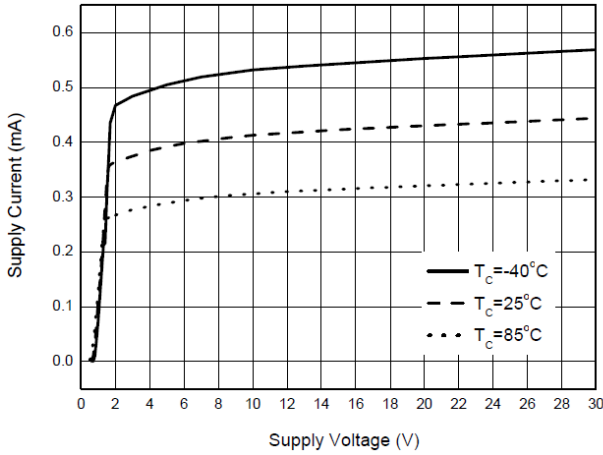

Fig. 1 Supply Current vs. Supply Voltage

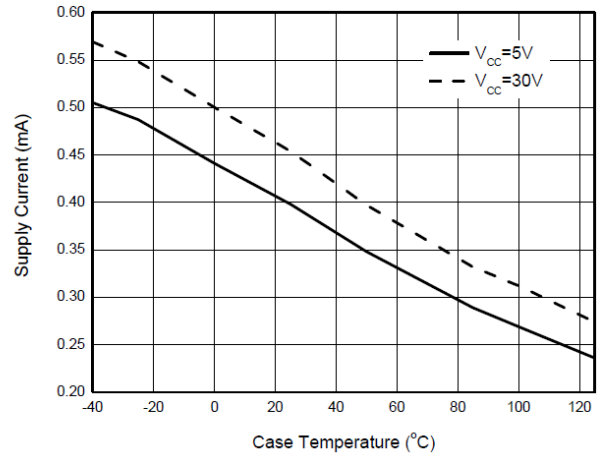

Fig. 2 Supply Current vs. Case Temperature

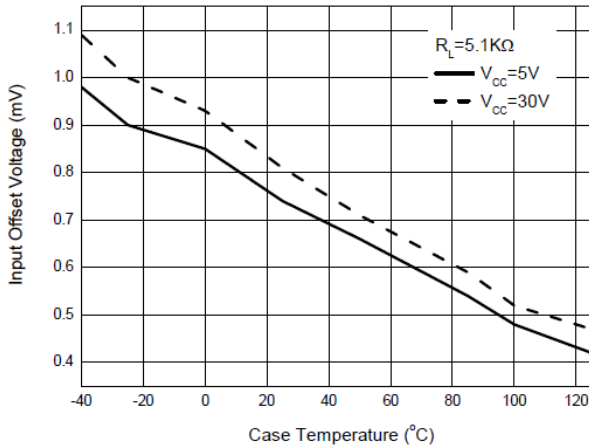

Fig. 3 Input Offset Voltage vs. Case Temperature

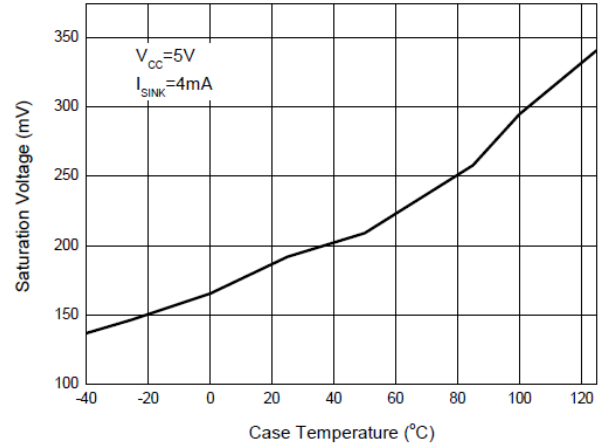

Fig. 4 Saturation Voltage vs. Case Temperature

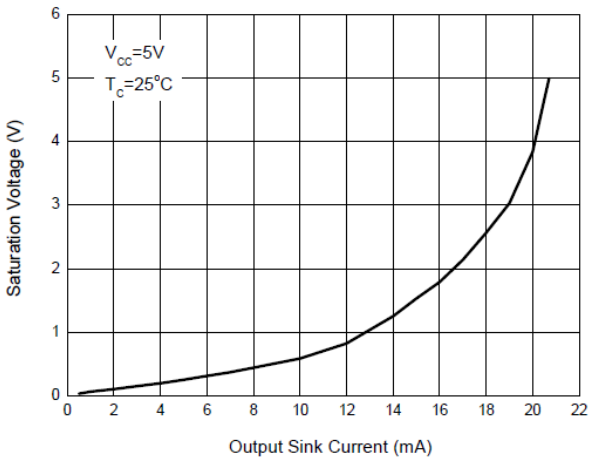

Fig. 5 Saturation Voltage vs. Output Sink Current

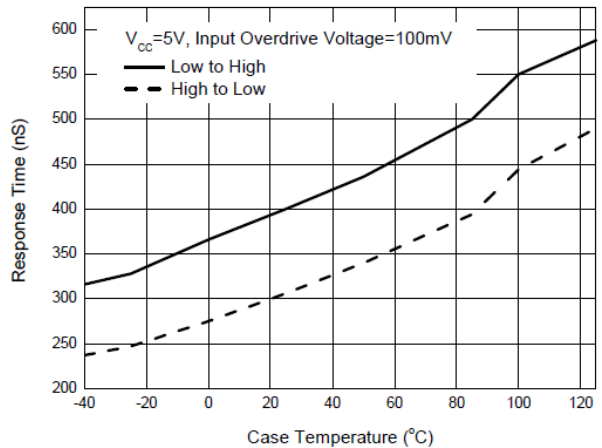

Fig. 6 Response Time vs. Case Temperature

Performance Characteristics (continued)

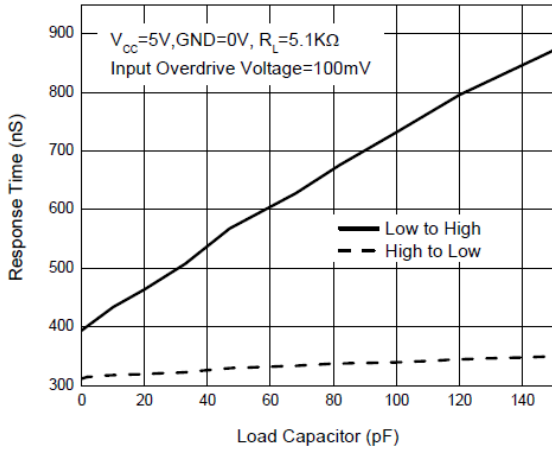

Fig. 7 Response Time vs. Load Capacitor

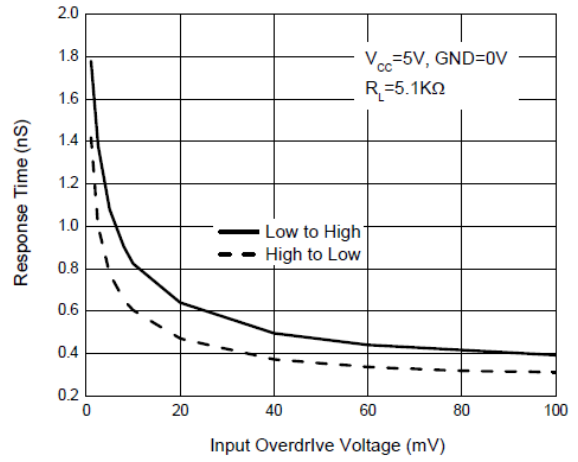

Fig. 8 Response Time vs. Input Overdrive Voltage

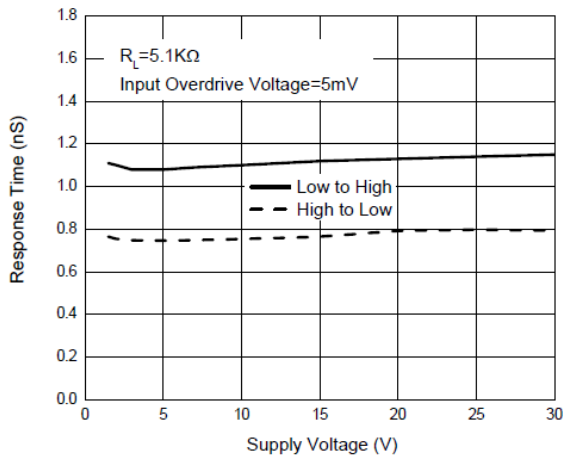

Fig. 9 Response Time vs. Supply Voltage

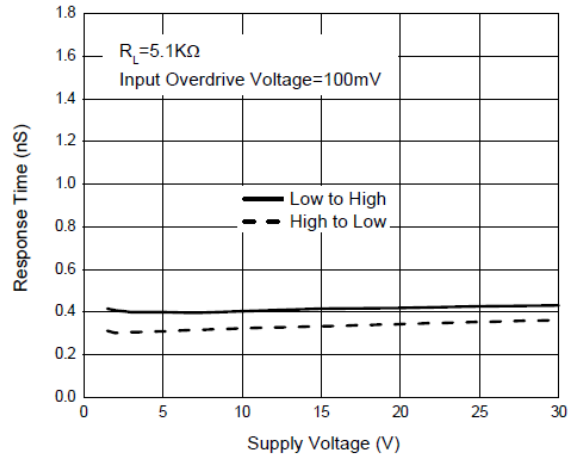

Fig. 10 Response Time vs. Supply Voltage

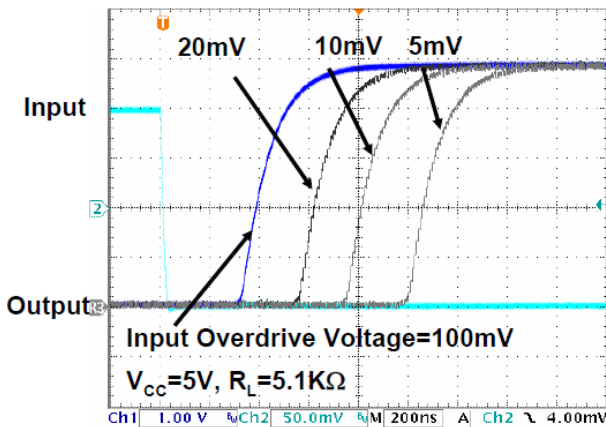

Fig. 11 Response Time for Positive Transition

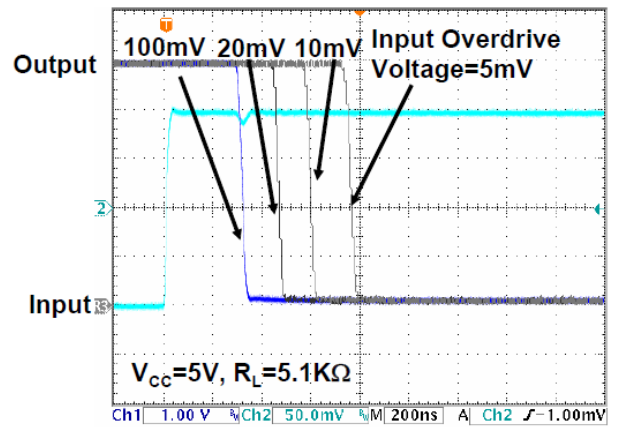

Fig. 12 Response Time for Negative Transition

Performance Characteristics (continued)

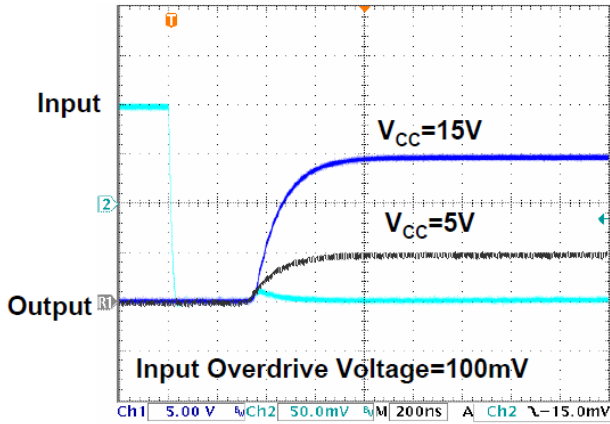

Fig. 13 Response Time for Positive Transition

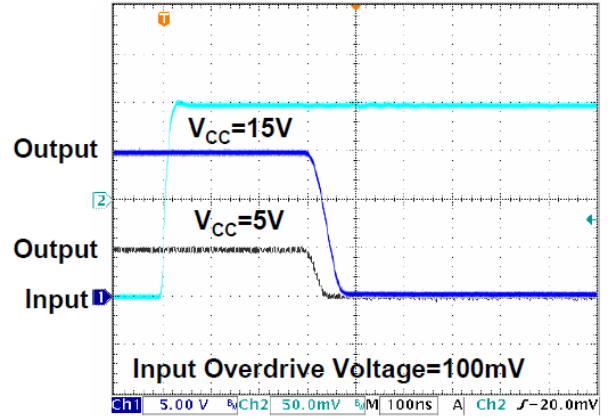

Fig. 14 Response Time for Negative Transition

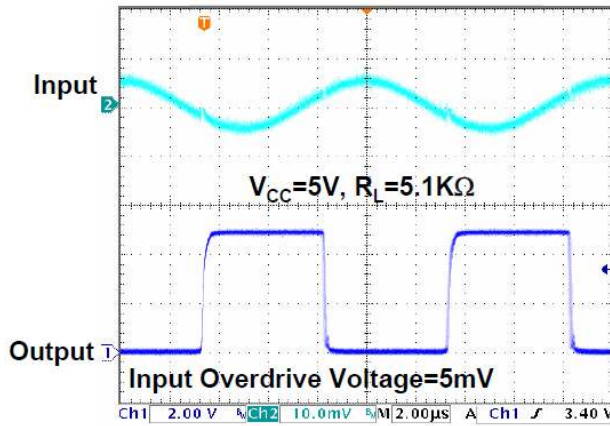

Fig. 15 100kHz Response

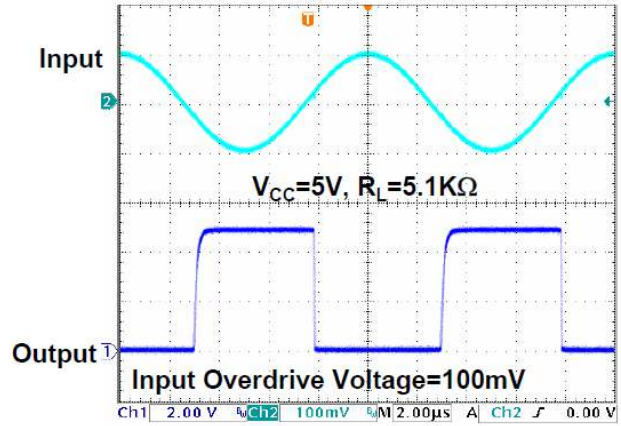

Fig. 16 100kHz Response

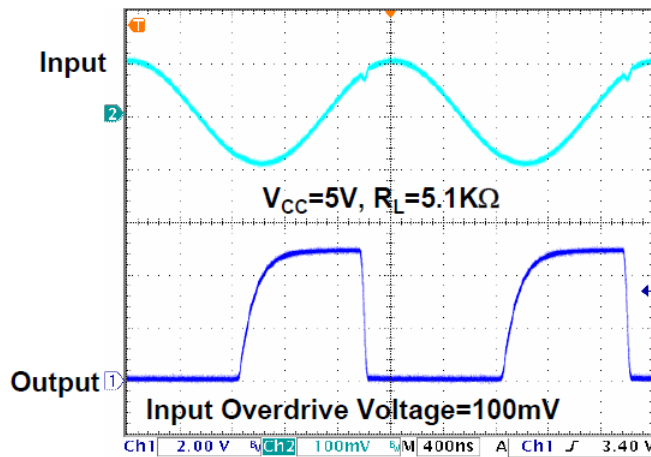
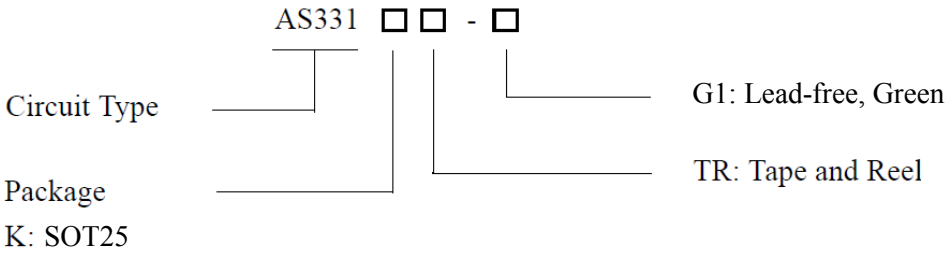

Fig. 17 500kHz Response

Ordering Information



Part Number	Marking ID	Package	Temperature Range	Packing Type
AS331KTR-G1	GEA	SOT25	-40 to 85°C	Tape & Reel

Marking Information

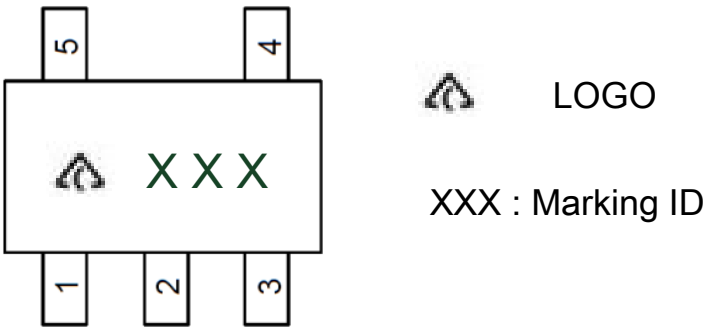

Package Outline Dimensions

Please see <http://www.diodes.com/package-outlines.html> for the latest version.

SOT25

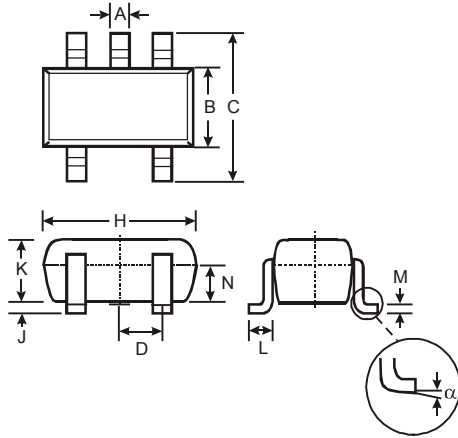

SOT25			
Dim	Min	Max	Typ
A	0.35	0.50	0.38
B	1.50	1.70	1.60
C	2.70	3.00	2.80
D	-	-	0.95
H	2.90	3.10	3.00
J	0.013	0.10	0.05
K	1.00	1.30	1.10
L	0.35	0.55	0.40
M	0.10	0.20	0.15
N	0.70	0.80	0.75
α	0°	8°	-
All Dimensions in mm			

Suggested Pad Layout

Please see <http://www.diodes.com/package-outlines.html> for the latest version.

SOT25

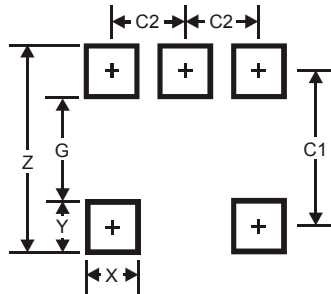

Dimensions	Value
Z	3.20
G	1.60
X	0.55
Y	0.80
C1	2.40
C2	0.95

Mechanical Data

- Moisture Sensitivity: Level 3 per J-STD-020
- Terminals: Finish – Matte Tin Plated Leads, Solderable per MIL-STD-202, Method 208 e3
- Weight: 0.016 grams (Approximate)

IMPORTANT NOTICE

1. DIODES INCORPORATED AND ITS SUBSIDIARIES (“DIODES”) MAKE NO WARRANTY OF ANY KIND, EXPRESS OR IMPLIED, WITH REGARDS TO ANY INFORMATION CONTAINED IN THIS DOCUMENT, INCLUDING, BUT NOT LIMITED TO, THE IMPLIED WARRANTIES OF MERCHANTABILITY, FITNESS FOR A PARTICULAR PURPOSE OR NON-INFRINGEMENT OF THIRD PARTY INTELLECTUAL PROPERTY RIGHTS (AND THEIR EQUIVALENTS UNDER THE LAWS OF ANY JURISDICTION).
2. The Information contained herein is for informational purpose only and is provided only to illustrate the operation of Diodes products described herein and application examples. Diodes does not assume any liability arising out of the application or use of this document or any product described herein. This document is intended for skilled and technically trained engineering customers and users who design with Diodes products. Diodes products may be used to facilitate safety-related applications; however, in all instances customers and users are responsible for (a) selecting the appropriate Diodes products for their applications, (b) evaluating the suitability of the Diodes products for their intended applications, (c) ensuring their applications, which incorporate Diodes products, comply the applicable legal and regulatory requirements as well as safety and functional-safety related standards, and (d) ensuring they design with appropriate safeguards (including testing, validation, quality control techniques, redundancy, malfunction prevention, and appropriate treatment for aging degradation) to minimize the risks associated with their applications.
3. Diodes assumes no liability for any application-related information, support, assistance or feedback that may be provided by Diodes from time to time. Any customer or user of this document or products described herein will assume all risks and liabilities associated with such use, and will hold Diodes and all companies whose products are represented herein or on Diodes’ websites, harmless against all damages and liabilities.
4. Products described herein may be covered by one or more United States, international or foreign patents and pending patent applications. Product names and markings noted herein may also be covered by one or more United States, international or foreign trademarks and trademark applications. Diodes does not convey any license under any of its intellectual property rights or the rights of any third parties (including third parties whose products and services may be described in this document or on Diodes’ website) under this document.
5. Diodes products are provided subject to Diodes’ Standard Terms and Conditions of Sale (<https://www.diodes.com/about/company/terms-and-conditions/terms-and-conditions-of-sales/>) or other applicable terms. This document does not alter or expand the applicable warranties provided by Diodes. Diodes does not warrant or accept any liability whatsoever in respect of any products purchased through unauthorized sales channel.
6. Diodes products and technology may not be used for or incorporated into any products or systems whose manufacture, use or sale is prohibited under any applicable laws and regulations. Should customers or users use Diodes products in contravention of any applicable laws or regulations, or for any unintended or unauthorized application, customers and users will (a) be solely responsible for any damages, losses or penalties arising in connection therewith or as a result thereof, and (b) indemnify and hold Diodes and its representatives and agents harmless against any and all claims, damages, expenses, and attorney fees arising out of, directly or indirectly, any claim relating to any noncompliance with the applicable laws and regulations, as well as any unintended or unauthorized application.
7. While efforts have been made to ensure the information contained in this document is accurate, complete and current, it may contain technical inaccuracies, omissions and typographical errors. Diodes does not warrant that information contained in this document is error-free and Diodes is under no obligation to update or otherwise correct this information. Notwithstanding the foregoing, Diodes reserves the right to make modifications, enhancements, improvements, corrections or other changes without further notice to this document and any product described herein. This document is written in English but may be translated into multiple languages for reference. Only the English version of this document is the final and determinative format released by Diodes.
8. Any unauthorized copying, modification, distribution, transmission, display or other use of this document (or any portion hereof) is prohibited. Diodes assumes no responsibility for any losses incurred by the customers or users or any third parties arising from any such unauthorized use.

Copyright © 2021 Diodes Incorporated

www.diodes.com