

BGB420

Active Biased Transistor

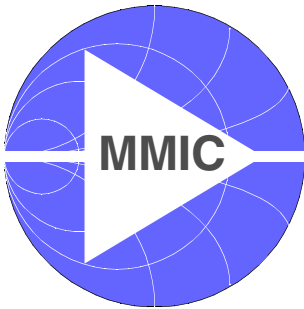

Wireless
Silicon Discretes



Never stop thinking.

Edition 2001-08-10

**Published by Infineon Technologies AG,
St.-Martin-Strasse 53,
D-81541 München**

**© Infineon Technologies AG 2001
All Rights Reserved.**

Attention please!

The information herein is given to describe certain components and shall not be considered as warranted characteristics.

Terms of delivery and rights to technical change reserved.

We hereby disclaim any and all warranties, including but not limited to warranties of non-infringement, regarding circuits, descriptions and charts stated herein.

Infineon Technologies is an approved CECC manufacturer.

Information

For further information on technology, delivery terms and conditions and prices please contact your nearest Infineon Technologies Office in Germany or our Infineon Technologies Representatives worldwide (see address list).

Warnings

Due to technical requirements components may contain dangerous substances. For information on the types in question please contact your nearest Infineon Technologies Office.

Infineon Technologies Components may only be used in life-support devices or systems with the express written approval of Infineon Technologies, if a failure of such components can reasonably be expected to cause the failure of that life-support device or system, or to affect the safety or effectiveness of that device or system. Life support devices or systems are intended to be implanted in the human body, or to support and/or maintain and sustain and/or protect human life. If they fail, it is reasonable to assume that the health of the user or other persons may be endangered.

BGB420**Data sheet****Revision History: 2001-08-10**Previous Version: 2000-11-28

Page	Subjects (major changes since last revision)
7	S-Parameter table added
8	Figure "Output Compression Point" added
9	SPICE Model added

For questions on technology, delivery and prices please contact the Infineon Technologies Offices in Germany or the Infineon Technologies Companies and Representatives worldwide: see our webpage at <http://www.infineon.com>

Features

- For high gain low noise amplifiers
- Ideal for wideband applications, cellular telephones, cordless telephones, SAT-TV and high frequency oscillators
- $G_{ma}=17.5\text{dB}$ at 1.8GHz
- Small SOT343 package
- Current easy adjustable by an external resistor
- Open collector output
- Typical supply voltage: 1.4-3.3V
- SIEGET[®]-25 technology

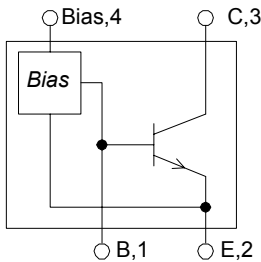
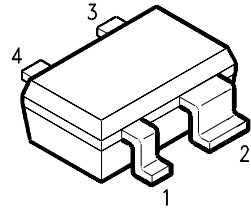

Description

SIEGET[®]-25 NPN Transistor with integrated biasing for high gain low noise figure applications. I_C can be controlled using I_{Bias} according to $I_C=10 \cdot I_{Bias}$.

ESD: Electrostatic discharge sensitive device, observe handling precaution!

Type	Package	Marking	Chip
BGB420	SOT343	MBs	T0514

Maximum Ratings

Parameter	Symbol	Value	Unit
Maximum collector-emitter voltage	V_{CE}	3.5	V
Maximum collector current	I_C	30	mA
Maximum bias current	I_{Bias}	3	mA
Maximum emitter-base voltage	V_{EB}	1.5	V
Maximum base current	I_B	0.7	mA
Total power dissipation, $T_S < 107^\circ\text{C}^{1)}$	P_{tot}	120	mW
Junction temperature	T_j	150	$^\circ\text{C}$
Operating temperature range	T_{OP}	-40 ..+85	$^\circ\text{C}$
Storage temperature range	T_{STG}	-65 ... +150	$^\circ\text{C}$
Thermal resistance: junction-soldering point	$R_{th JS}$	<270	K/W

Notes:

For detailed symbol description refer to figure 1.

¹⁾ T_S is measured on the emitter lead at the soldering point to the PCB

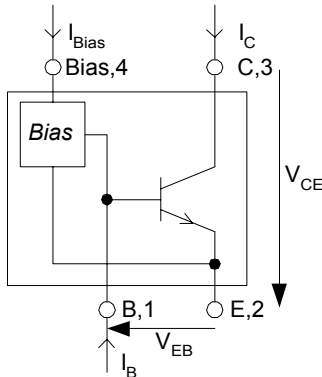

Fig. 1: Symbol definition

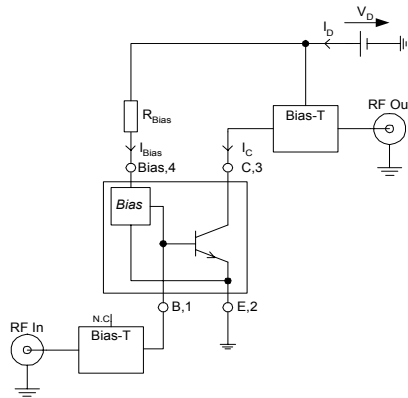

Fig. 2: Test Circuit for Electrical Characteristics and S-Parameter

Electrical Characteristics at $T_A=25^\circ\text{C}$ (measured in test circuit specified in fig. 2, min./max. values verified by random sampling)

Parameter	Symbol	min.	typ.	max.	Unit
Maximum available power gain $V_D=2\text{V}$, $I_C=20\text{mA}$, $f=1.8\text{GHz}$	G_{MA}	16.0	17.5		dB
Insertion power gain $V_D=2\text{V}$, $I_C=20\text{mA}$	$ S_{21} ^2$		22 16		dB
Insertion loss $V_D=2\text{V}$, $I_C=0\text{mA}$	IL		21 15		dB
Noise figure ($Z_S=50\Omega$) $V_D=2\text{V}$, $I_C=5\text{mA}$	$F_{50\Omega}$		1.3 1.5	1.8 2.0	dB
Output power at 1dB gain compression $V_D=2\text{V}$, $I_C=20\text{mA}$, $f=1.8\text{GHz}$ $Z_L=Z_{\text{LOPT}}$ $Z_L=50\Omega$	$P_{-1\text{dB}}$	7	12 10		dBm
Output third order intercept point $V_D=2\text{V}$, $I_C=20\text{mA}$, $f=1.8\text{GHz}$ $Z_{L/S}=Z_{L/S\text{OPT}}$ $Z_{L/S}=50\Omega$	OIP_3	17	22 20		dBm
Collector-base capacitance $V_{\text{CB}}=2\text{V}$, $f=1\text{MHz}$	C_{CB}		0.16		pF
Current Ratio I_C/I_{Bias} $I_{\text{Bias}}=0.5\text{mA}$, $V_D=3\text{V}$	CR	7	10	13	

S-Parameter $V_D=2V$, $I_C=20mA$ (see Electrical Characteristics for conditions)

Frequency [GHz]	S11 Mag	S11 Ang	S21 Mag	S21 Ang	S12 Mag	S12 Ang	S22 Mag	S22 Ang
0.1	0.4412	-24.8	35.7070	160.6	0.0078	83.5	0.9225	-14.1
0.2	0.4064	-47.4	31.7670	143.9	0.0157	77.5	0.8321	-26.2
0.4	0.3261	-81.6	23.1980	120.9	0.0261	70.9	0.6380	-41.4
0.6	0.2854	-105.8	17.2590	106.9	0.0351	69.4	0.5012	-49.6
0.8	0.2615	-124.2	13.5050	97.5	0.0444	68.9	0.4100	-54.2
1.0	0.2525	-136.4	10.9810	90.6	0.0537	68.2	0.3435	-57.4
1.2	0.2505	-148.9	9.1940	84.8	0.0628	67.3	0.2946	-60.2
1.4	0.2476	-158.2	7.8930	80.1	0.0720	65.9	0.2571	-62.6
1.6	0.2533	-167.1	6.9070	75.6	0.0819	64.6	0.2228	-64.2
1.8	0.2579	-173.3	6.1460	71.7	0.0915	62.9	0.1966	-66.0
2.0	0.2584	-178.7	5.5300	68.2	0.1009	61.4	0.1751	-66.3
3.0	0.2874	157.6	3.6990	51.6	0.1495	51.7	0.0802	-70.1
4.0	0.3505	139.0	2.7770	36.1	0.1970	40.4	0.0366	-178.8
5.0	0.4061	125.9	2.1930	21.5	0.2392	29.4	0.0913	126.7
6.0	0.4450	117.1	1.8050	8.6	0.2864	18.9	0.1340	99.8

Device Current $I_D = f(V_D, R_{Bias})$

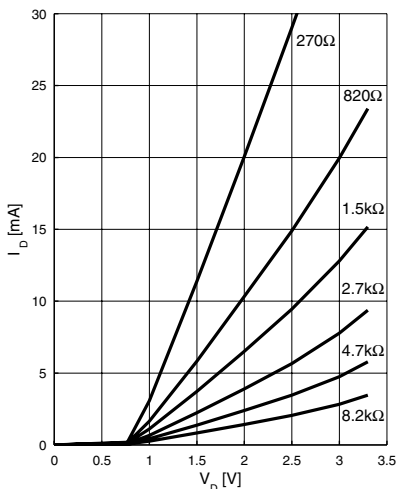

Power Gain $|S_{21}|^2$, Gma, Gms=f(f)
 $V_D = 3V, I_C = 20mA$

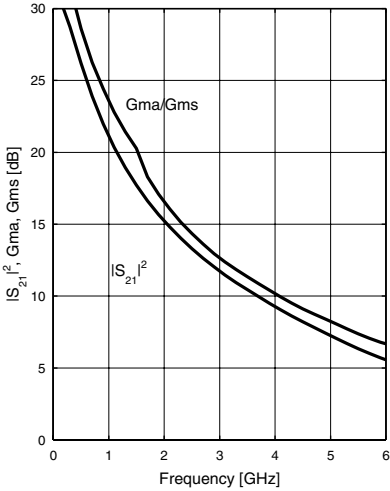

Power Gain Gma, Gms=f(I_C)
 $V_D = 3V$

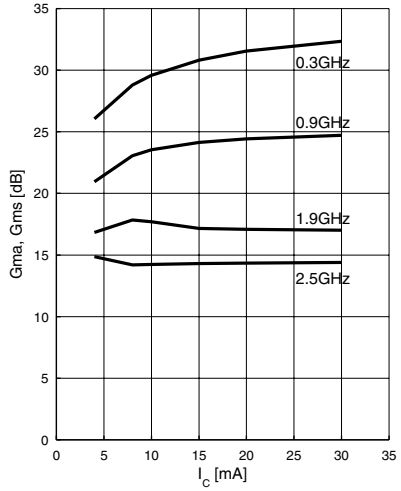

Matching $|S_{11}|, |S_{22}|=f(f)$
 $V_D = 3V, I_C = 20mA$

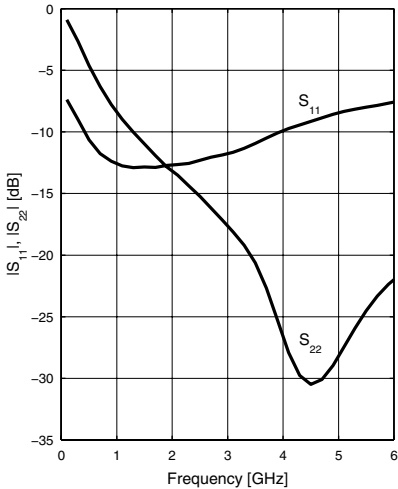

Output Compression Point

$P_{-1dB} = f(I_C)$
 $V_D = 3V, f = 1.8GHz, Z_L = 50\Omega$

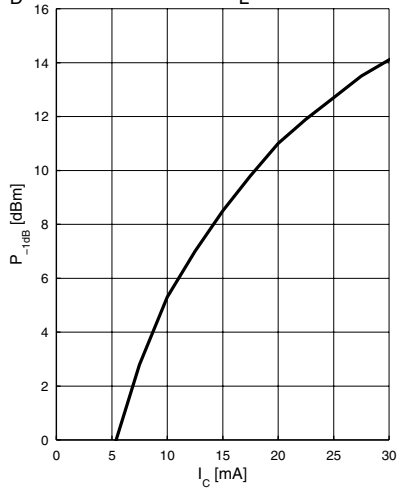

SPICE Model

BGB420-Chip

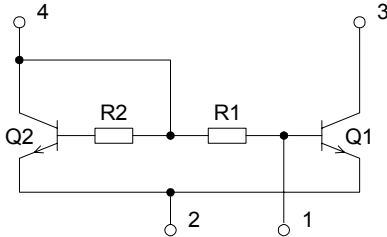

Q1	T502
Q2	T502 (area factor: 0.1)
R1	2.7kΩ
R2	27kΩ

Transistor Chip Data T502 (Berkley-SPICE 2G.6 Syntax)

.MODEL T502 NPN(

+ IS = 2.0045e-16	BF = 72.534	NF = 1.2432	VAF = 28.383
+ IKF = 0.48731	ISE = 1.9049e-14	NE = 2.0518	BR = 7.8287
+ NR = 1.3325	VAR = 19.705	IKR = 0.69141	ISC = 1.9237e-17
+ NC = 1.1724	RB = 8.5757	IRB = 0.00072983	RBM = 3.4849
+ RE = 0.31111	RC = 0.10105	CJE = 1.8063e-15	VJE = 0.8051
+ MJE = 0.46576	TF = 6.7661e-12	XTF = 0.42199	VTF = 0.23794
+ ITF = 0.001	PTF = 0	CJC = 2.3453e-13	VJC = 0.81969
+ MJC = 0.30232	XCJC = 0.3	TR = 2.3249e-09	CJS = 0
+ VJS = 0.75	MJS = 0	XTB = 0	EG = 1.11
+ XTI = 3	FC = 0.73234)		

Package Equivalent Circuit

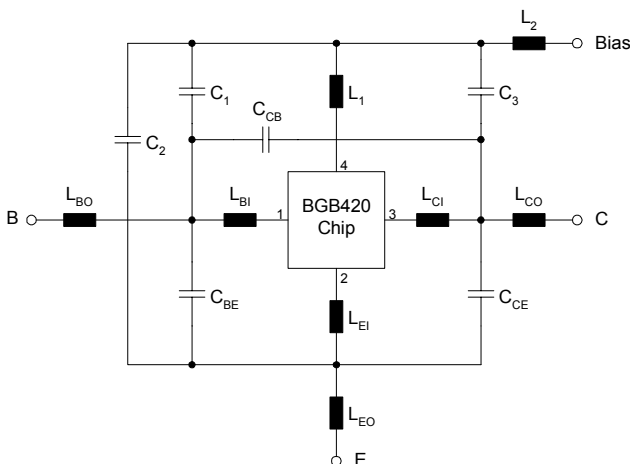

L _{BI}	0.36	nH
L _{BO}	0.4	nH
L _{EI}	0.3	nH
L _{EO}	0.15	nH
L _{CI}	0.36	nH
L _{CO}	0.4	nH
L ₁	0.6	nH
L ₂	0.4	nH
C _{BE}	95	fF
C _{CB}	6	fF
C _{CE}	132	fF
C ₁	28	fF
C ₂	88	fF
C ₃	8	fF

Valid up to 3GHz

Typical Application

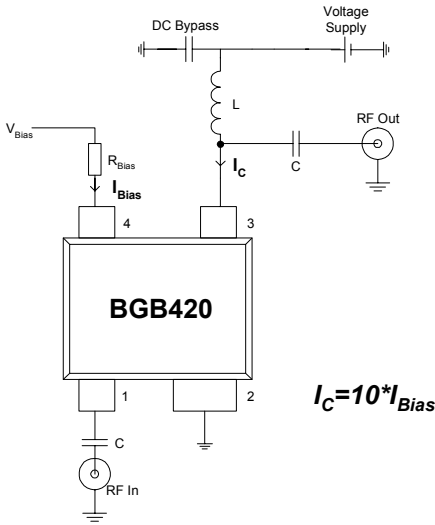
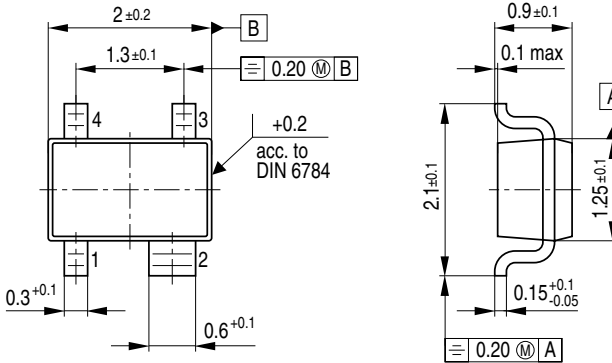

Fig. 3: Typical application circuit. This proposal demonstrates how to use the BGB420 as a Self-Biased Transistor. As for a discrete Transistor matching circuits have to be applied. A good starting point for various applications are the Application Notes provided for the BFP420.

Package Outline



GPS05605