

## Description

The AP5004 is a step-down switching regulator with PWM control and includes a reference voltage source, oscillation circuit, error amplifier, and an internal NMOS.

AP5004 provides low-ripple power, high efficiency, and excellent transient characteristics. The PWM control circuit is able to vary the duty ratio linearly from 0% up to 90%. An enable function, an over-current protect function, and a short circuit protect function are built inside, and when OCP or SCP happens, the operation frequency will be reduced from 300 KHz to 50 KHz. Also, an internal compensation block has been designed in to minimize the external component count.

With built-in power NMOS, a step-down switching regulator can easily be built by adding a coil, capacitors, and a diode.

The combination of high efficiency, low standby current, high input voltage (32V), and high output current (2.5A) in a small SOP-8L package gives the AP5004 an unprecedented advantage in any high power system applications.

## Features

- Input Voltage: 10V to 32V
- Adjustable Output Voltage from 0.8V to 6V
- Duty Ratio: 0% to 90% PWM control
- Oscillation Frequency: 300KHz typical
- Short Circuit Protect Frequency: 50 KHz
- 2uA Maximum Standby Current
- Current Limit, Enable Function
- Thermal Shutdown Function
- Built-in Internal SW N-channel MOS
- SOP-8L: Available in "Green" Molding Compound (No Br, Sb)
- Lead Free Finish/ RoHS Compliant (Note 1)

Notes: 1. EU Directive 2002/95/EC (RoHS). All applicable RoHS exemptions applied. Please visit our website at [http://www.diodes.com/products/lead\\_free.html](http://www.diodes.com/products/lead_free.html).

## Pin Assignments

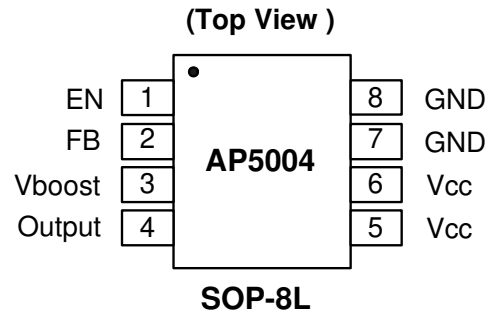

## Applications

- Microprocessor Core Supply
- Networking Power Supply
- LCD MNT, TV Power Supply
- Telecom Power Supply

**Typical Application Circuit**

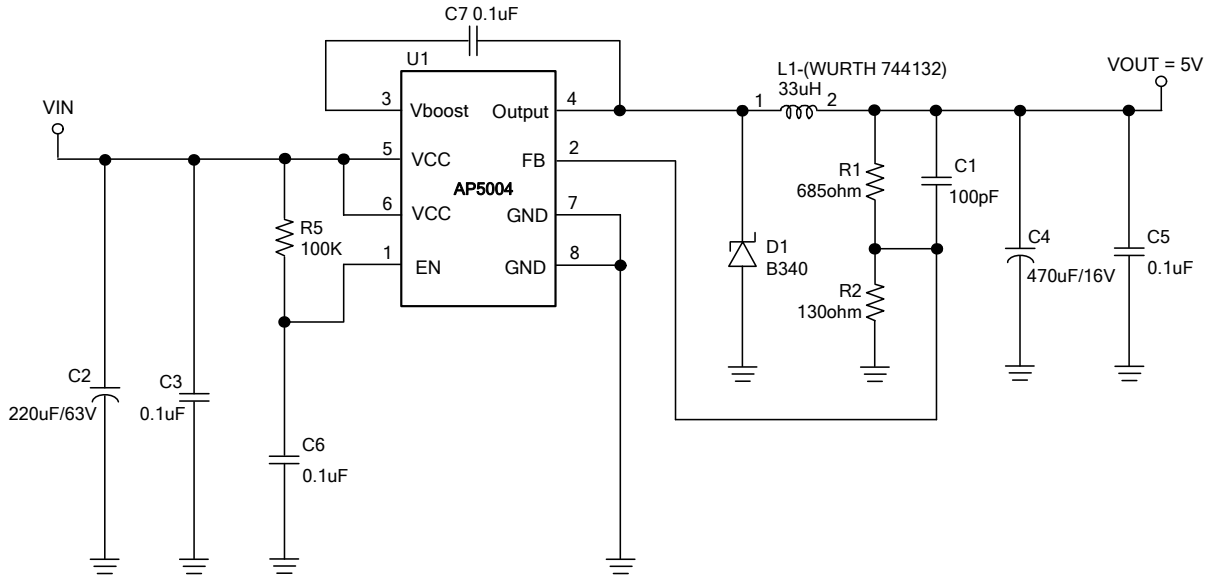

Note:  $V_{OUT} = V_{FB} \times (1 + R1/R2)$   
 $R_B = 100 \sim 300 \text{ ohm}$

Notes: 2. Suggested DIODES Power Schottky P/N: PDS540 or B540C.

**Pin Descriptions**

Pin Name	Pin #	Description
EN	1	H: Normal operation L: Step-down operation stopped
FB	2	Feedback pin
V <sub>boost</sub>	3	High-side gate driver boost pin
Output	4	Switch output pin
V <sub>CC</sub>	5、6	V <sub>CC</sub>
GND	7、8	GND pin

**Functional Block Diagram**

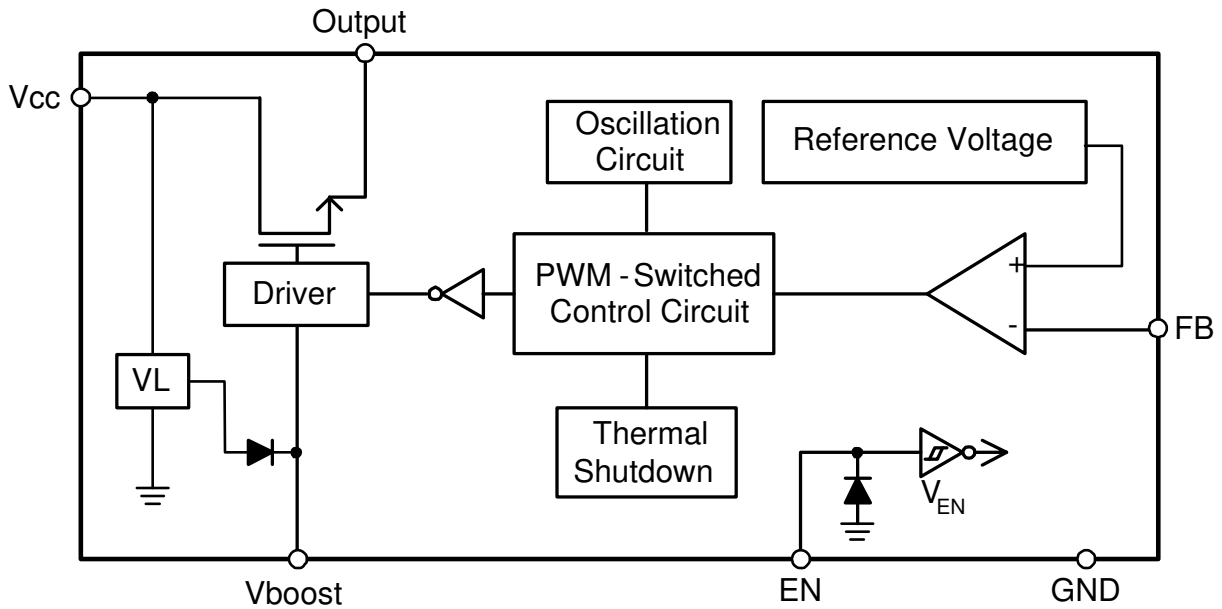

**Absolute Maximum Ratings**

Symbol	Parameter	Rating	Unit
ESD HBM	Human Body Model ESD Protection	1.8	KV
ESD MM	Machine Model ESD Protection	550	V
$V_{CC}$	VCC Pin Voltage	$V_{SS} - 0.3$ to $V_{SS} + 35$	V
$V_{FB}$	$V_{OUT}$ Pin Voltage	$V_{SS} - 0.3$ to $V_{CC}$	V
$V_{EN}$	EN Pin Voltage	$V_{SS} - 0.3$ to $V_{CC} + 0.3$	V
$V_{boost}$	$V_{boost}$ Pin Voltage	$V_{OUTPUT} + 7V$	V
$V_{OUTPUT}$	Switch Pin Voltage	$V_{SS} - 0.3$ to $V_{CC} + 0.3$	V
$T_J$	Operating Junction Temperature Range	-10 to +125	°C
$T_{ST}$	Storage Temperature Range	-40 to +150	°C

Caution: The absolute maximum ratings are rated values exceeding which the product could suffer physical damage. These values must therefore not be exceeded under any conditions.

**Recommended Operating Conditions**

Symbol	Parameter	Min	Max	Unit
$V_{IN}$	Input Voltage	10	32	V
$I_{OUT}$	Output Current	0	2.5	A
$T_A$	Operating Ambient Temperature	-10	85	°C

### Electrical Characteristics ( $V_{IN} = 12V$ , $T_A = 25^\circ C$ , unless otherwise specified)

Symbol	Parameter	Conditions	Min	Typ.	Max	Unit
$V_{FB}$	Feedback Voltage		0.780	0.8	0.820	V
$V_{IN}$	Input Voltage		10	-	32	V
$I_{STBY}$	Standby Current	$V_{EN} = 0V$	-	2	-	$\mu A$
$\Delta V_{OUT}/V_{OUT}$	Line Regulation	$V_{IN} = 10V \sim 32V$	-	$\pm 1.0$	$\pm 1.5$	%/V
$\Delta V_{OUT}/V_{OUT}$	Load Regulation	$I_{OUT} = 0.1$ to 2.5A	-	1	1.5	%
$f_{OSC}$	Oscillation Frequency	Measure waveform at SW pin	240	300	360	KHz
$f_{OSC1}$	Frequency of Current Limit or Short Circuit Protect	Measure waveform at SW pin	-	50	-	KHz
DC	Maximum Duty Cycle	$V_{FB} = 0.5V$	-	90	-	%
	Minimum Duty Cycle	$V_{FB} = 1.0V$	-	0	-	%
$V_{IH}$	EN Pin Logic Input Threshold Voltage	Regulator ON	2.0	-	-	V
$V_{IL}$		Regulator OFF	-	-	0.8	
$I_{SH}$	EN Pin Input Leakage Current		-	20	-	$\mu A$
$I_{SL}$			-	-10	-	$\mu A$
$R_{DS(ON)}$	Internal MOSFET $R_{DS(ON)}$		-	80	120	m $\Omega$
$I_{LIMIT}$	Current Limit		3.5	-	-	A
$\eta$	Efficiency	$V_{IN} = 12V$ , $V_{OUT} = 5V$ , $I_{OUT} = 2.5A$	-	90	-	%
$\theta_{JA}$	Thermal Resistance Junction-to-Ambient	SOP-8L (Note 3)	-	124	-	$^\circ C/W$
$\theta_{JC}$	Thermal Resistance Junction-to-Case	SOP-8L (Note 3)	-	25	-	$^\circ C/W$

Notes: 3. Test condition for SOP-8L: Device mounted on 2oz copper, minimum recommended pad layout, FR-4 PCB.

**Typical Performance Characteristics**

**Load Regulation**

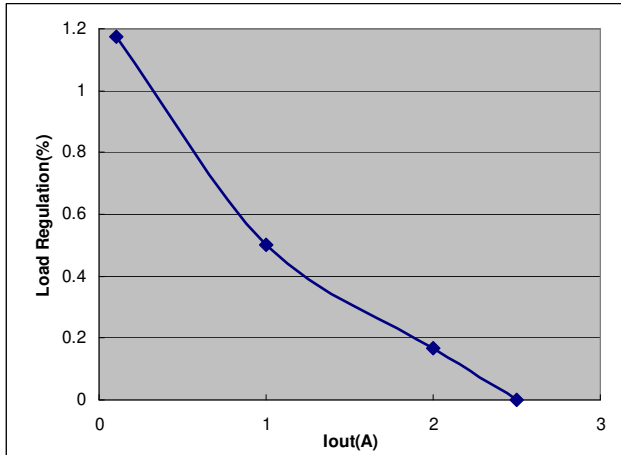

**Line Regulation**

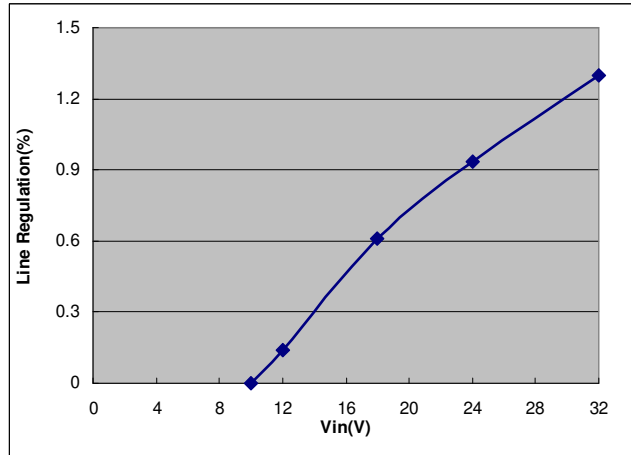

**Frequency vs. Vin**

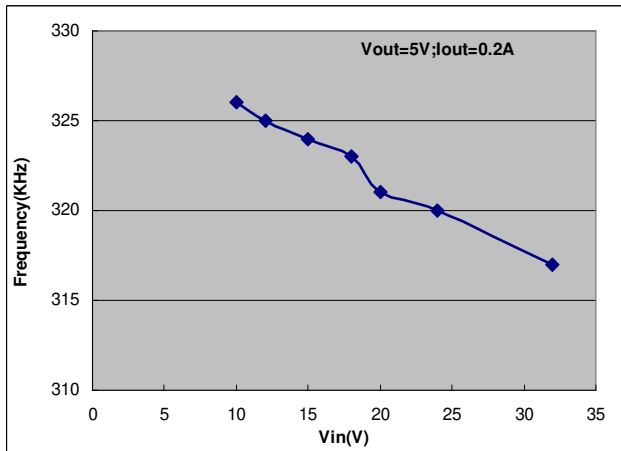

**Iccq vs. Vin**

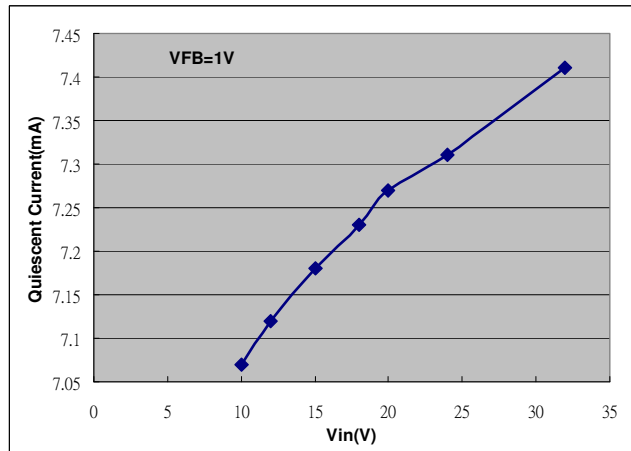

**Istandby vs. Vin**

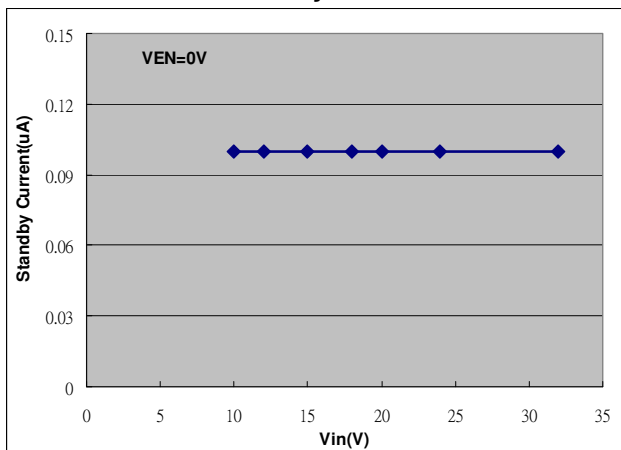

**Typical Performance Characteristics (Continued)**

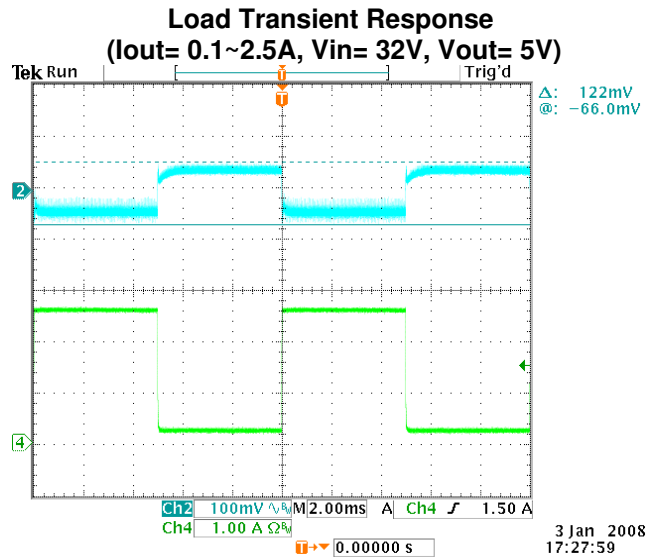
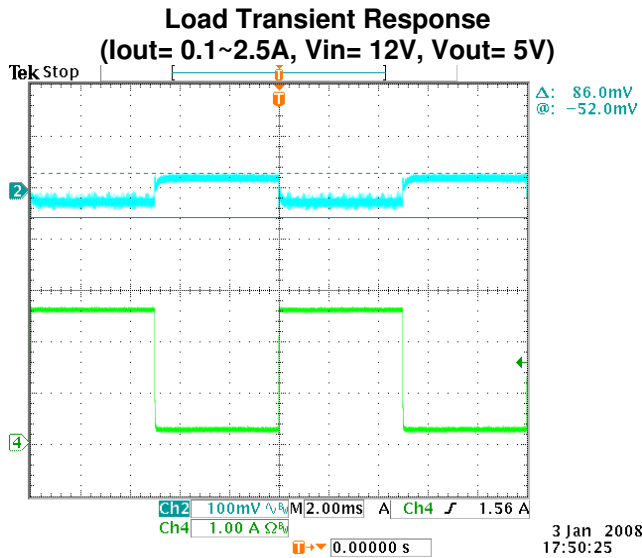
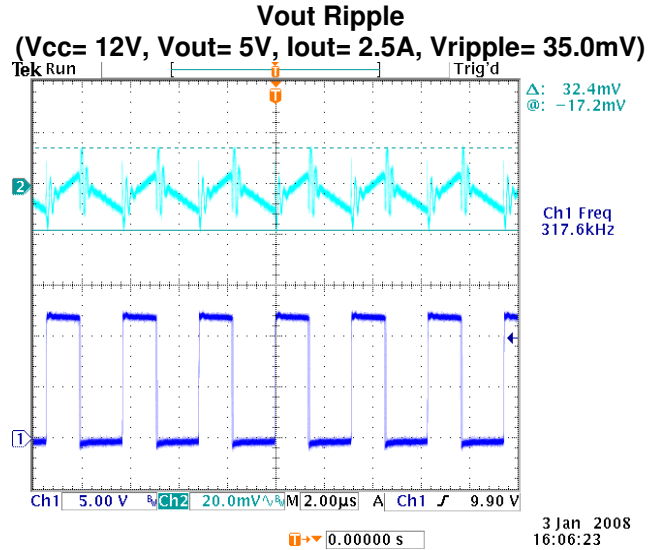
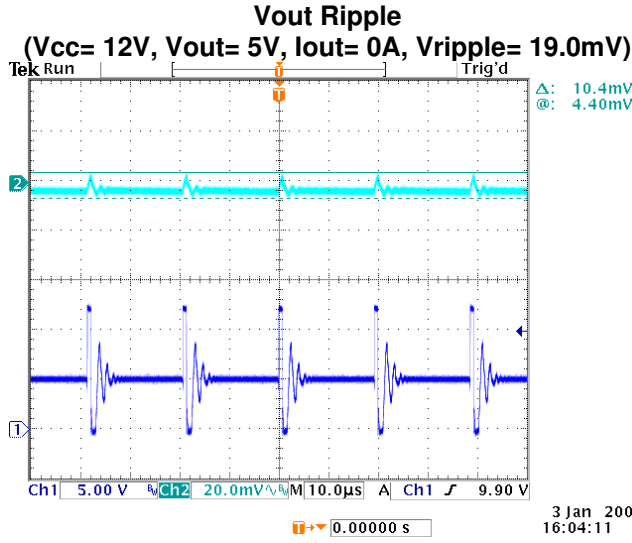

**Test Circuit**

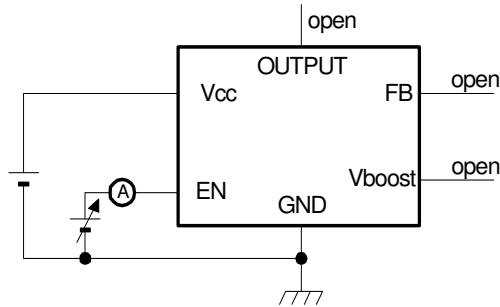

**Enable function test**

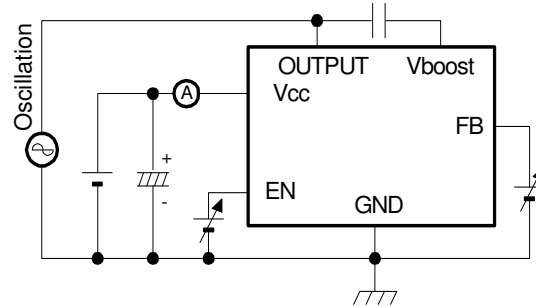

**Feedback function test**

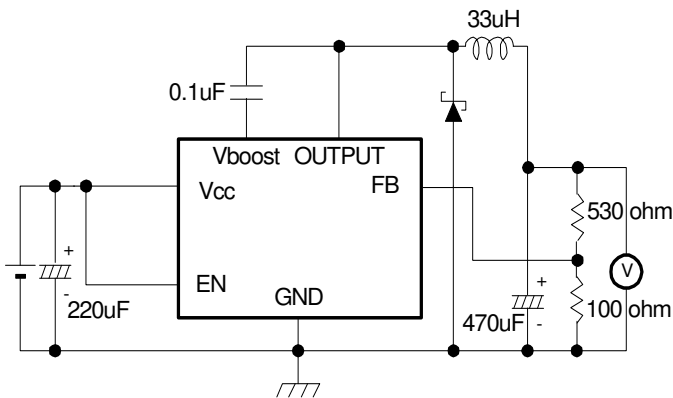

**Operation function test**

---

## Functional Description

---

### PWM Control

The AP5004 consists of DC/DC converters that employ a pulse-width modulation (PWM) system. The PWM controller is internally clocked by a fixed 300KHz oscillator.

When used as a converter, the AP5004's pulse width varies in a range from 0% to 90%, according to the load current. The ripple voltage produced by the switching can easily be removed through a filter because the switching frequency remains constant. Therefore, these converters provide a low-ripple power over broad ranges of input voltage and load current.

### Enable Control

The Enable Control allows the output of the AP5004 to be turned ON or OFF. Connecting the Enable pin to GND or any voltage source lower than 0.8V will turn the output OFF. In the OFF state, the current drawn through the  $V_{CC}$  input is approximately 2 $\mu$ A. Please note that the slew rate from ON to OFF must be >0.013V/ $\mu$ s to ensure proper operation.

### BOOST Capacitor

This capacitor boosts the gate drive to the internal MOSFET above  $V_{IN}$  to fully turn it ON thus minimizing conduction losses in the power switch to maintain high efficiency. The recommended value of the capacitor is 0.1 $\mu$ F. The capacitor must be connected from pin 3 to the switch output, pin 4.

### Feedback

This is the input to a two-stage high gain amplifier, which drives the PWM controller. Two external resistors are required to set the DC output voltage. For stable operation of the power supply, it is important to prevent coupling of any inductor flux to the feedback input.

### Current Limit

The current limit threshold is set by the internal circuit such that the minimum switching current is 3.5A. If the switching current exceeds the threshold, the output voltage will drop and the switching frequency will be reduced to 50KHz.

### Inductor Selection

Most designs operate with inductors of 15 $\mu$ H to 33 $\mu$ H. The inductor value can be derived from the following equation:

$$L = \frac{(V_{IN} - V_{OUT})V_{OUT}}{\Delta I_L \times f_{osc} \times V_{IN}}$$

Large value inductors will result in a lower ripple current where as small value inductors will result in high ripple currents. The inductor ripple current should be set to approximately 15% of the maximum load current 2.5A,  $\Delta I_L=0.375A$ . The DC current rating of the inductor should be at least equal to the maximum load current plus half the ripple current to prevent core saturation (2A+0.19A).

### Input Capacitor Selection

The input current to the step-down converter is discontinuous, and therefore an input capacitor C2 is required to supply the AC current to the step-down converter while maintaining the DC input voltage. A low ESR capacitor is required to keep the noise at the IC to a minimum. Its RMS current rating should be greater than approximately half of the DC load current.



**Functional Description (Continued)**

**Output Capacitor Selection**

An output capacitor is required to maintain the DC output voltage. Low ESR capacitors are preferred to keep the output voltage ripple low. The characteristics of the output capacitor also affect the stability of the regulation control system. The ESR dominates the impedance at the switching frequency. The output ripple is calculated as:

$$V_{\text{RIPPLE}} \cong \Delta I \times \text{RESR}$$

**Output Rectifier Diode**

The output rectifier diode supplies the current to the inductor when the high-side switch is OFF. To reduce losses due to the diode forward voltage and recovery times, use a Schottky rectifier.

**PCB Layout Guide**

The dual Output pin (4) and VSS pins (7 & 8) on the SOP-8L package are internally connected to die pad. If low  $T_C$  &  $T_J$  or a large PD (Power Dissipation) is needed, the PCB layout should allow for maximum possible copper area exposure at the SW pins. Please also follow the steps below to reduce switching noise.

1. Connect C3 to VCC and VSS pin as closely as possible to get good power filter effect.
2. Connect ground side of the C2 & D1 as closely as possible.

Typical PC Board Layout:

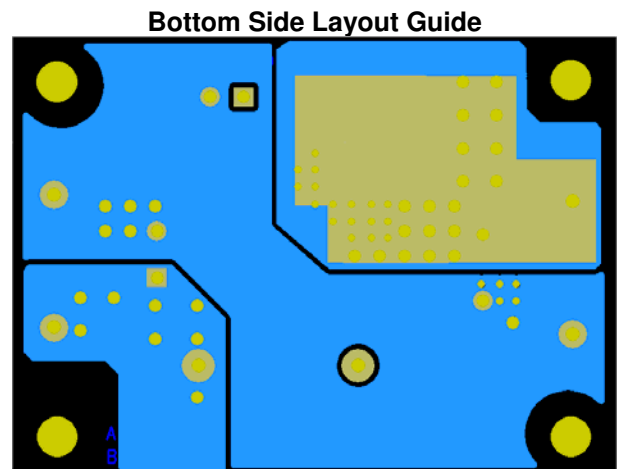
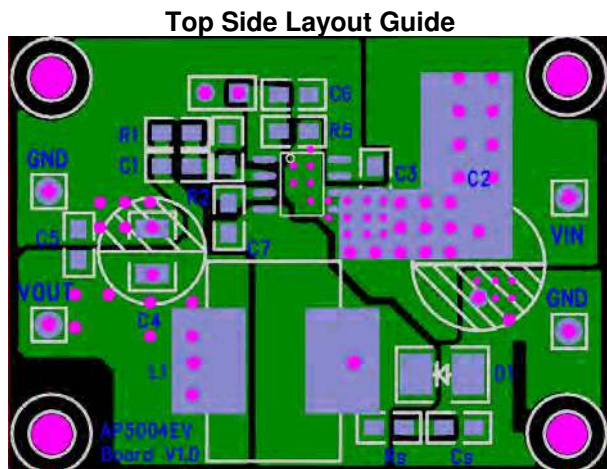

**Ordering Information**

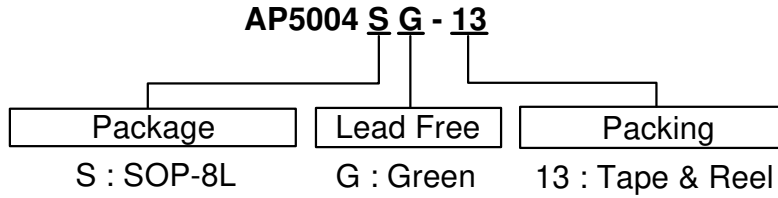

Device	Package Code	Packaging (Note 4)	13" Tape and Reel	
			Quantity	Part Number Suffix
AP5004SG-13	S	SOP-8L	2500/Tape & Reel	-13

Notes: 4. Pad layout as shown on Diodes Inc. suggested pad layout document AP02001, which can be found on our website at <http://www.diodes.com/datasheets/ap02001.pdf>.

**Marking Information**

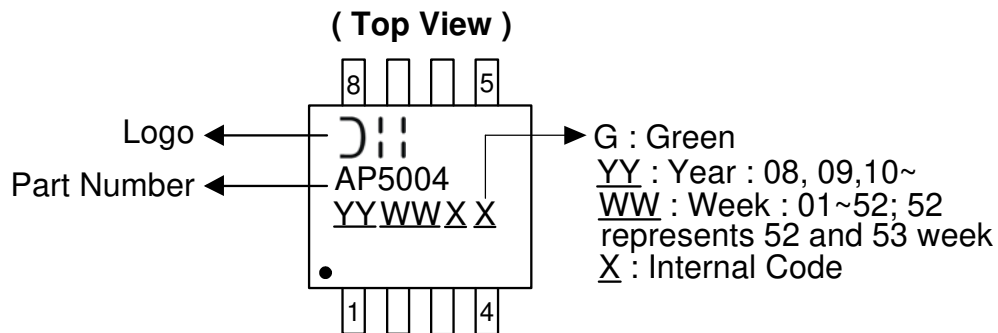

**Package Outline Dimensions (All Dimensions in mm)**

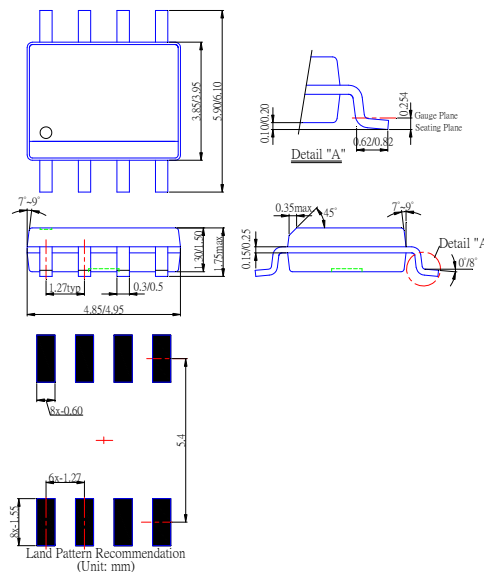

**IMPORTANT NOTICE**

DIODES INCORPORATED MAKES NO WARRANTY OF ANY KIND, EXPRESS OR IMPLIED, WITH REGARDS TO THIS DOCUMENT, INCLUDING, BUT NOT LIMITED TO, THE IMPLIED WARRANTIES OF MERCHANTABILITY AND FITNESS FOR A PARTICULAR PURPOSE (AND THEIR EQUIVALENTS UNDER THE LAWS OF ANY JURISDICTION).

Diodes Incorporated and its subsidiaries reserve the right to make modifications, enhancements, improvements, corrections or other changes without further notice to this document and any product described herein. Diodes Incorporated does not assume any liability arising out of the application or use of this document or any product described herein; neither does Diodes Incorporated convey any license under its patent or trademark rights, nor the rights of others. Any Customer or user of this document or products described herein in such applications shall assume all risks of such use and will agree to hold Diodes Incorporated and all the companies whose products are represented on Diodes Incorporated website, harmless against all damages.

Diodes Incorporated does not warrant or accept any liability whatsoever in respect of any products purchased through unauthorized sales channel.

Should Customers purchase or use Diodes Incorporated products for any unintended or unauthorized application, Customers shall indemnify and hold Diodes Incorporated and its representatives harmless against all claims, damages, expenses, and attorney fees arising out of, directly or indirectly, any claim of personal injury or death associated with such unintended or unauthorized application.

Products described herein may be covered by one or more United States, international or foreign patents pending. Product names and markings noted herein may also be covered by one or more United States, international or foreign trademarks.

**LIFE SUPPORT**

Diodes Incorporated products are specifically not authorized for use as critical components in life support devices or systems without the express written approval of the Chief Executive Officer of Diodes Incorporated. As used herein:

A. Life support devices or systems are devices or systems which:

1. are intended to implant into the body, or
2. support or sustain life and whose failure to perform when properly used in accordance with instructions for use provided in the labeling can be reasonably expected to result in significant injury to the user.

B. A critical component is any component in a life support device or system whose failure to perform can be reasonably expected to cause the failure of the life support device or to affect its safety or effectiveness.

Customers represent that they have all necessary expertise in the safety and regulatory ramifications of their life support devices or systems, and acknowledge and agree that they are solely responsible for all legal, regulatory and safety-related requirements concerning their products and any use of Diodes Incorporated products in such safety-critical, life support devices or systems, notwithstanding any devices- or systems-related information or support that may be provided by Diodes Incorporated. Further, Customers must fully indemnify Diodes Incorporated and its representatives against any damages arising out of the use of Diodes Incorporated products in such safety-critical, life support devices or systems.

Copyright © 2010, Diodes Incorporated

[www.diodes.com](http://www.diodes.com)