

1

2

3

4

5

RoHS Compliant

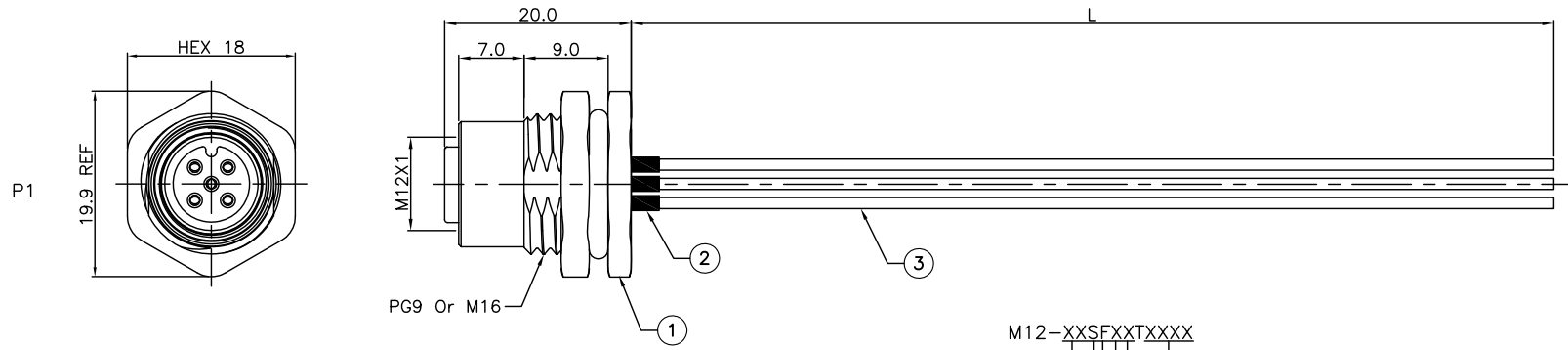

M12-XXSFXXTXXXX

- Cable Length
- 0050:50mm;0100:100mm
- 0150:150mm;0200:200mm
- 0250:250mm;0300:300mm
- 0400:400mm;0500:500mm
- 1:PG9 2:M16
- A:A Coding D:D Coding
- F:Front Fastened
- S:Socket
- No.of Contacts

A Coding						
	2Pin	3Pin	4Pin	5Pin	6Pin	7Pin
D Coding						
	8Pin	9Pin	10Pin	11Pin	12Pin	
	2Pin	3Pin	4Pin	5Pin		

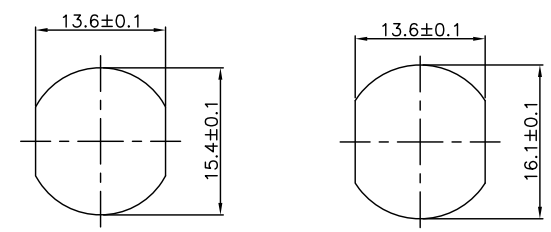

PG9 Recommended Panel CUT-Out Thickness:4.0mm
M16 Recommended Panel CUT-Out Thickness:4.0mm

ITEM	PART NO.	DESCRIPTION	Q'TY
1	M12-XXS-FX-PMX	M12 Socket Front Fastened Solder Type	1
2	825-H.S-XX-BK	Heat Shrink Tube Color:Black	A/R
3	809-TPEXXTSW-XX	TPE XXAWG Wire Color:XX	A/R

F				DRAWN: Andrew	GENERAL TOLERANCE:	
E					.X=±0.50	L≤300=±5
D				CHECKED: Bill He	.XX=±0.30	L>300=±10
C					UNIT: MM	
B				APPROVAL: Bill He	SCALE: 1:1	
A	01-Jul-2022		Andrew		SHEET: 1/2	
REV	DATE	FILE	BY	PROJECTION:		

OST
ON-SHORE TECHNOLOGY, INC.

DESCRIPTION:
M12 SOCKET FRONT FASTENED WIRE HARNESS

PART NO:
M12-XXSFXXTXXXX

A
B
C
D

1

2

3

4

5

RoHS Compliant

2P PIN OUT:

P1	
1	Black
3	Brown

ITEM	PART NO.	DESCRIPTION	Q'TY
1	M12-02S-FX-PMX	M12 2Pin Socket Front Fastened Solder Type	1
2	825-H.S-XX-BK	Heat Shrink Tube Color:Black	A/R
3	809-TPE22TSW-XX	TPE 22AWG Wire Color:XX	A/R

9P PIN OUT:

P1	
1	Black
2	White
3	Brown
4	Red
5	Yellow
6	Blue
7	Orange
8	Green
9	Purple

ITEM	PART NO.	DESCRIPTION	Q'TY
1	M12-09S-FX-PMX	M12 9Pin Socket Front Fastened Solder Type	1
2	825-H.S-XX-BK	Heat Shrink Tube Color:Black	A/R
3	809-TPE26TSW-XX	TPE 26AWG Wire Color:XX	A/R

3P PIN OUT:

P1	
1	Black
3	Brown
4	Red

ITEM	PART NO.	DESCRIPTION	Q'TY
1	M12-03S-FX-PMX	M12 3Pin Socket Front Fastened Solder Type	1
2	825-H.S-XX-BK	Heat Shrink Tube Color:Black	A/R
3	809-TPE22TSW-XX	TPE 22AWG Wire Color:XX	A/R

10P PIN OUT:

P1	
1	Black
2	White
3	Brown
4	Red
5	Yellow
6	Blue
7	Orange
8	Green
9	Purple
10	Grey

ITEM	PART NO.	DESCRIPTION	Q'TY
1	M12-10S-FX-PMX	M12 10Pin Socket Front Fastened Solder Type	1
2	825-H.S-XX-BK	Heat Shrink Tube Color:Black	A/R
3	809-TPE26TSW-XX	TPE 26AWG Wire Color:XX	A/R

4P PIN OUT:

P1	
1	Black
2	White
3	Brown
4	Red

ITEM	PART NO.	DESCRIPTION	Q'TY
1	M12-04S-FX-PMX	M12 4Pin Socket Front Fastened Solder Type	1
2	825-H.S-XX-BK	Heat Shrink Tube Color:Black	A/R
3	809-TPE22TSW-XX	TPE 22AWG Wire Color:XX	A/R

5P PIN OUT:

P1	
1	Black
2	White
3	Brown
4	Red
5	Yellow

ITEM	PART NO.	DESCRIPTION	Q'TY
1	M12-05S-FX-PMX	M12 5Pin Socket Front Fastened Solder Type	1
2	825-H.S-XX-BK	Heat Shrink Tube Color:Black	A/R
3	809-TPE22TSW-XX	TPE 22AWG Wire Color:XX	A/R

6P PIN OUT:

P1	
1	Black
2	White
3	Brown
4	Red
5	Yellow
6	Blue

ITEM	PART NO.	DESCRIPTION	Q'TY
1	M12-06S-FX-PMX	M12 6Pin Socket Front Fastened Solder Type	1
2	825-H.S-XX-BK	Heat Shrink Tube Color:Black	A/R
3	809-TPE24TSW-XX	TPE 24AWG Wire Color:XX	A/R

11P PIN OUT:

P1	
1	Black
2	White
3	Brown
4	Red
5	Yellow
6	Blue
7	Orange
8	Green
9	Purple
10	Grey
11	Pink

ITEM	PART NO.	DESCRIPTION	Q'TY
1	M12-11S-FX-PMX	M12 11Pin Socket Front Fastened Solder Type	1
2	825-H.S-XX-BK	Heat Shrink Tube Color:Black	A/R
3	809-TPE26TSW-XX	TPE 26AWG Wire Color:XX	A/R

7P PIN OUT:

P1	
1	Black
2	White
3	Brown
4	Red
5	Yellow
6	Blue
7	Orange

ITEM	PART NO.	DESCRIPTION	Q'TY
1	M12-07S-FX-PMX	M12 7Pin Socket Front Fastened Solder Type	1
2	825-H.S-XX-BK	Heat Shrink Tube Color:Black	A/R
3	809-TPE24TSW-XX	TPE 24AWG Wire Color:XX	A/R

12P PIN OUT:

P1	
1	Black
2	White
3	Brown
4	Red
5	Yellow
6	Blue
7	Orange
8	Green
9	Purple
10	Grey
11	Pink
12	Light Green

ITEM	PART NO.	DESCRIPTION	Q'TY
1	M12-12S-FX-PMX	M12 12Pin Socket Front Fastened Solder Type	1
2	825-H.S-XX-BK	Heat Shrink Tube Color:Black	A/R
3	809-TPE26TSW-XX	TPE 26AWG Wire Color:XX	A/R

8P PIN OUT:

P1	
1	Black
2	White
3	Brown
4	Red
5	Yellow
6	Blue
7	Orange
8	Green

ITEM	PART NO.	DESCRIPTION	Q'TY
1	M12-08S-FX-PMX	M12 8Pin Socket Front Fastened Solder Type	1
2	825-H.S-XX-BK	Heat Shrink Tube Color:Black	A/R
3	809-TPE24TSW-XX	TPE 24AWG Wire Color:XX	A/R

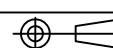
F				DRAWN: Andrew	GENERAL TOLERANCE:		 ON-SHORE TECHNOLOGY, INC.
E					CHECKED: Bill He	.X=±0.50	
D				APPROVAL: Andrew		UNIT: MM	
C					A	01-Jul-2022	Andrew
B				REV		DATE	FILE
				APPROVAL: Bill He	SCALE: 1:1		PROJECTION: 
					SHEET: 2/2		

A

B

C

D