

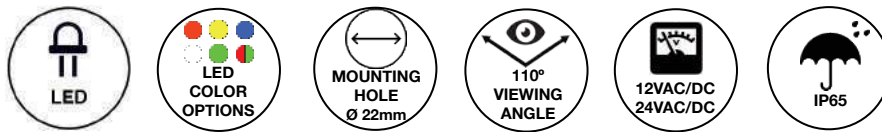

PCL22 Series Ø 0.88" (22mm) Pilot Light LED Panel Mount Indicator



PCL22 Series features a and modern design led pilot light for advance light diffusion, in several colors for easy application in different environments



Applications

- Industrial Machinery
- Transportation Dashboards
- Instrument Control Panels
- Maritime, Oil and Gas Industry
- Safety and Outdoor Applications
- Slot, Gaming and Vending Machines

Key Features

- For panel hole diameter: 0.88" (22mm)
- Low profile flat lenses for uniform illumination
- Mounting hardware provided: washer and nut
- Diffused translucent lenses provide uniform illumination
- Advance light diffusion technology which eliminate hot spots.
- Designed for extreme harsh and outdoor environments.
- Available in five solid colors (red, green, white, blue and yellow) and one bicolor (red/green).
- "Double D" mounting hole prevent any rotation of the Pilot Light while the nut is being installed.
- 2 voltage options: 12VAC/DC and 24VAC/DC
- Pilot lights feature a large lens for a wide viewing angle
- Maximum installation torque: 221 ft-lb (300 N-m)
- LED Life Expectancy: Approx. 50,000 hours
- IP65 protection rating protect panels against entry of dust and moisture
- Resistant to shock and vibration
- Retrofit solution: save energy and reduce costs
- Other colors are available upon request
- CE and CCC Mark Approvals
- RoHS and REACH Compliant

Ordering Data

The PCL22 Series is available in a range of standard features and options. To specify your Panel Mount Indicator, select one option from each column.

Part Numbers	Color/Voltage
PCL2212V100B	Red/12V
PCL2212V400B	White/12V
PCL2212V500B	Green/12V
PCL2212V600B	Blue/12V
PCL2212V700B	Yellow/12V
PCL2212V150B	Red/Green/12V
PCL2224V100B	Red/24V
PCL2224V400B	White/24V
PCL2224V500B	Green/24V
PCL2224V600B	Blue/24V
PCL2224V700B	Yellow/24V
PCL2224V150B	Red/Green/24V

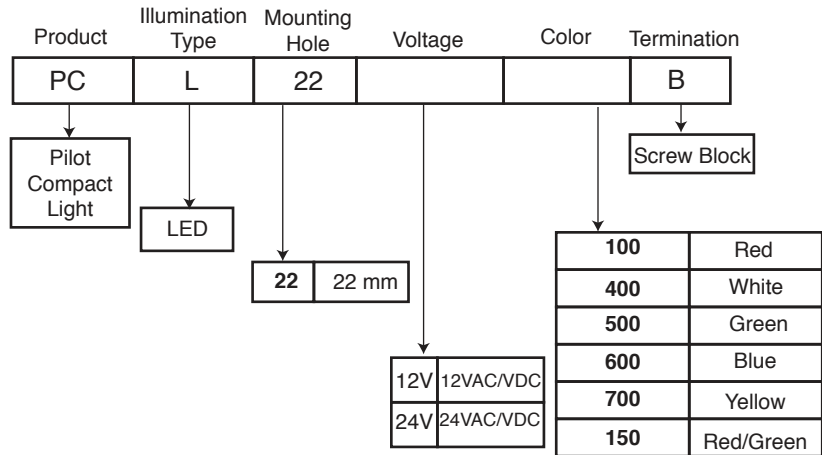

Installation Diagrams

Minimum Distance Required Between Mounting Holes

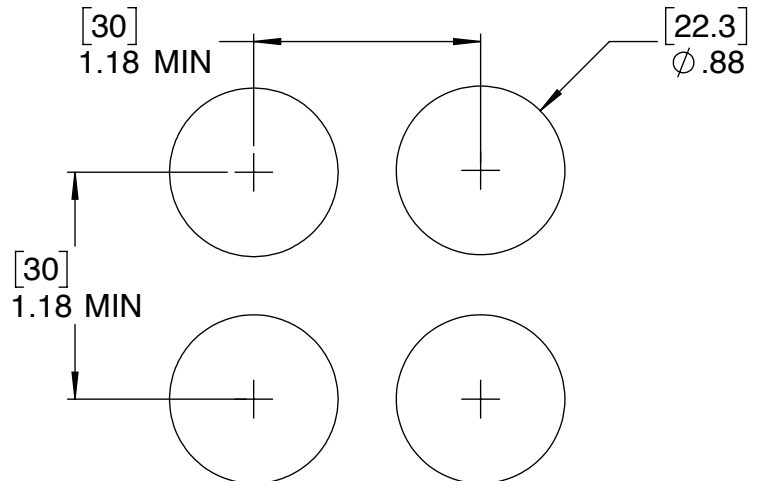
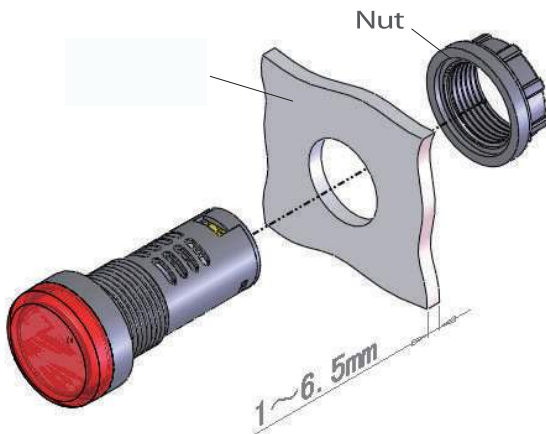

Notes:

1. All dimensions are in [millimeters] inches.
2. The specifications, characteristics and technical data described in the datasheet are subject to change without prior notice.

Product Dimensions

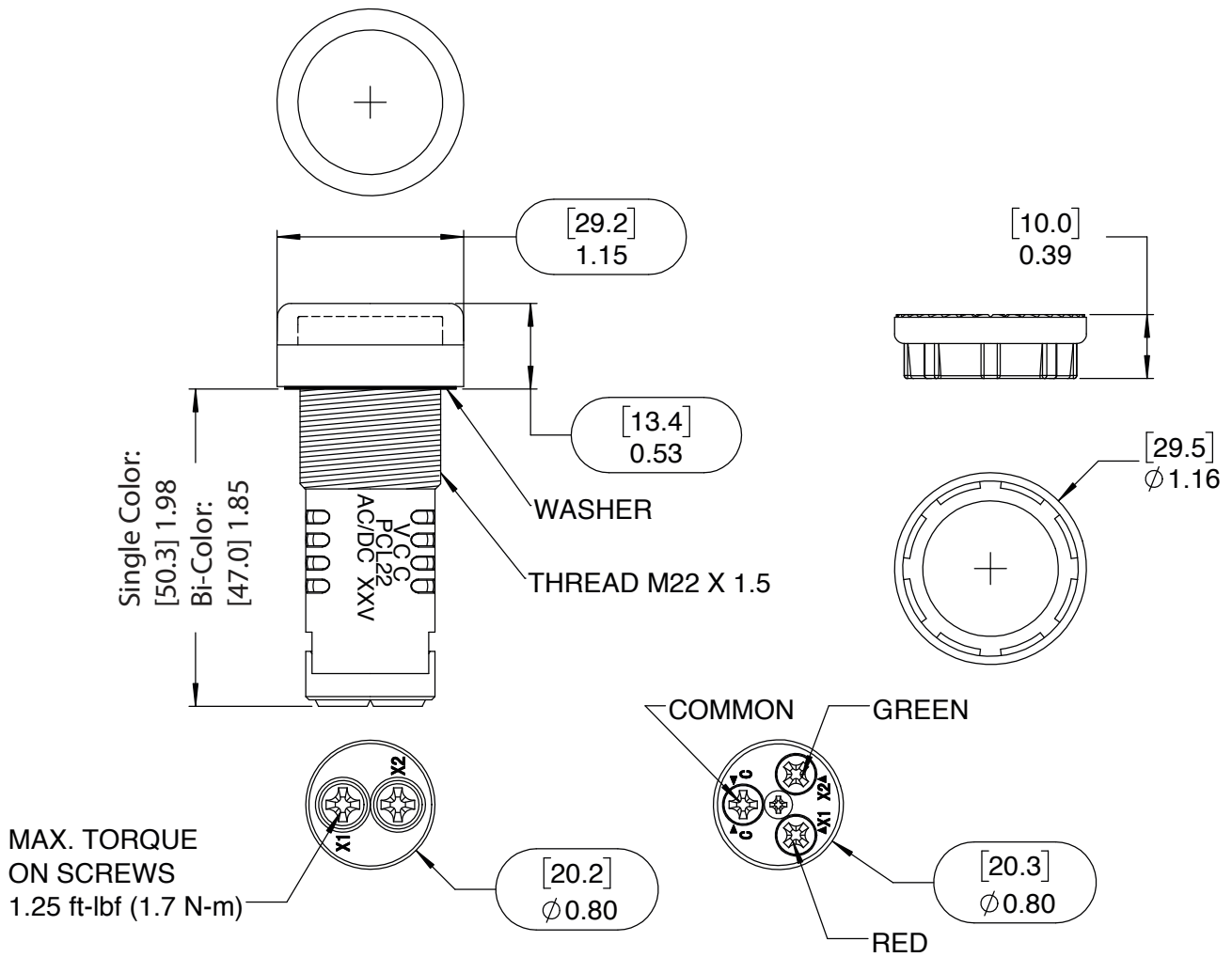

Recommended Mounting Holes

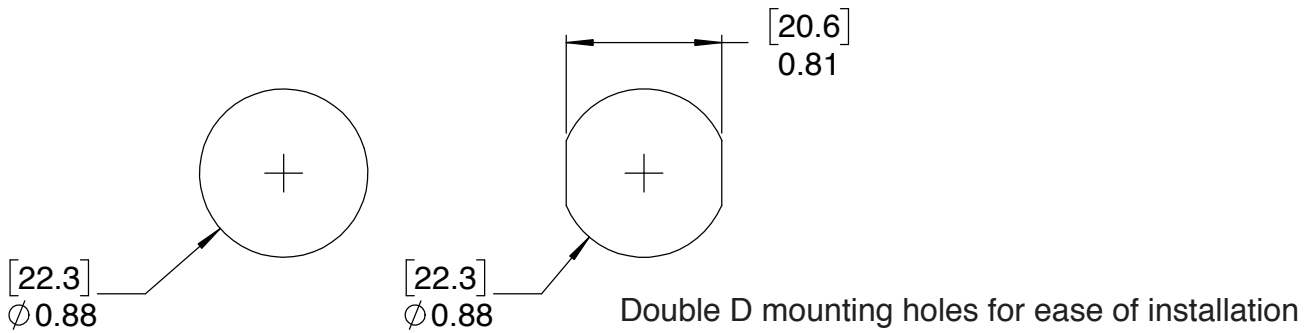

Notes:

1. All dimensions are in [millimeters] inches.
2. Tolerance is ± 0.4 mm or ± 0.02 in.
3. The specifications, characteristics and technical data described in the datasheet are subject to change without prior notice.

Product Specifications

Materials	
Housing	Black Polyamide 66 UL 94 V-0
Lens	Transparent Polycarbonate UL94 V-2
Diffuser	Acetal UL94 HB

Electrical Specifications	
Wattage	0.6W (for 12V Devices) 1.2W (for 24V Devices)
Operating Current	50mA (max.)
Frequency	50-60Hz

Temperature Specifications	
Operating Temperature	-25°C to +55°C -13°F to +131°F
Storage Temperature	-25°C to +55°C -13°F to +131°F

Installation Specifications	
Mounting Hole	0.880" (22.3 mm)
Panel Thickness	0.039" - 0.255" (1mm - 6.5mm)
Screw Block Bolt Torque Required	max. torque: 1.25 ft-lbf (1.7 Nm)
Mounting Torque (max.)	221 ft-lbs (300 N-m)

Optical Ratings:

Part Numbers	Color	Viewing Angle	Luminosity (mcd)	Wavelength (nm)
PCL22□V100B	Red	110°	≥75	620-630
PCL22□V400B	White	110°	≥75	445-450
PCL22□V500B	Green	110°	≥75	515-517
PCL22□V600B	Blue	110°	≥75	462-465
PCL22□V700B	Yellow	110°	≥75	585-588
PCL22□V150B	Red/Green	110°	≥75	620-630/515-517

Compliances and Approvals

