

LOC	DIST	REVISIONS			
GP	00	REV	DESCRIPTION	DATE	APP'D
E1	REVISED PER	ECO-11-005033		23MAR11	RK HMR

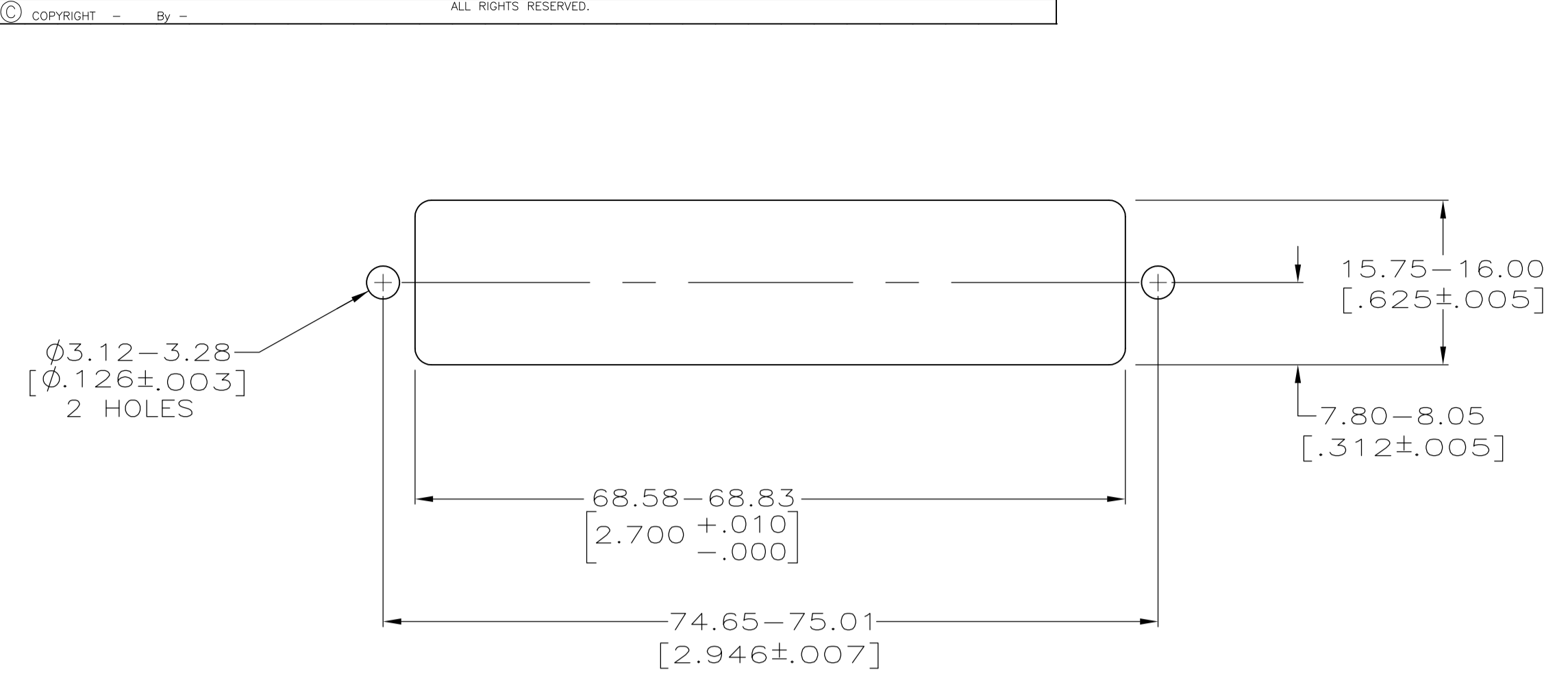

SUGGESTED REAR PANEL MOUNTING CUTOUT DIMENSIONS SCALE 2:1

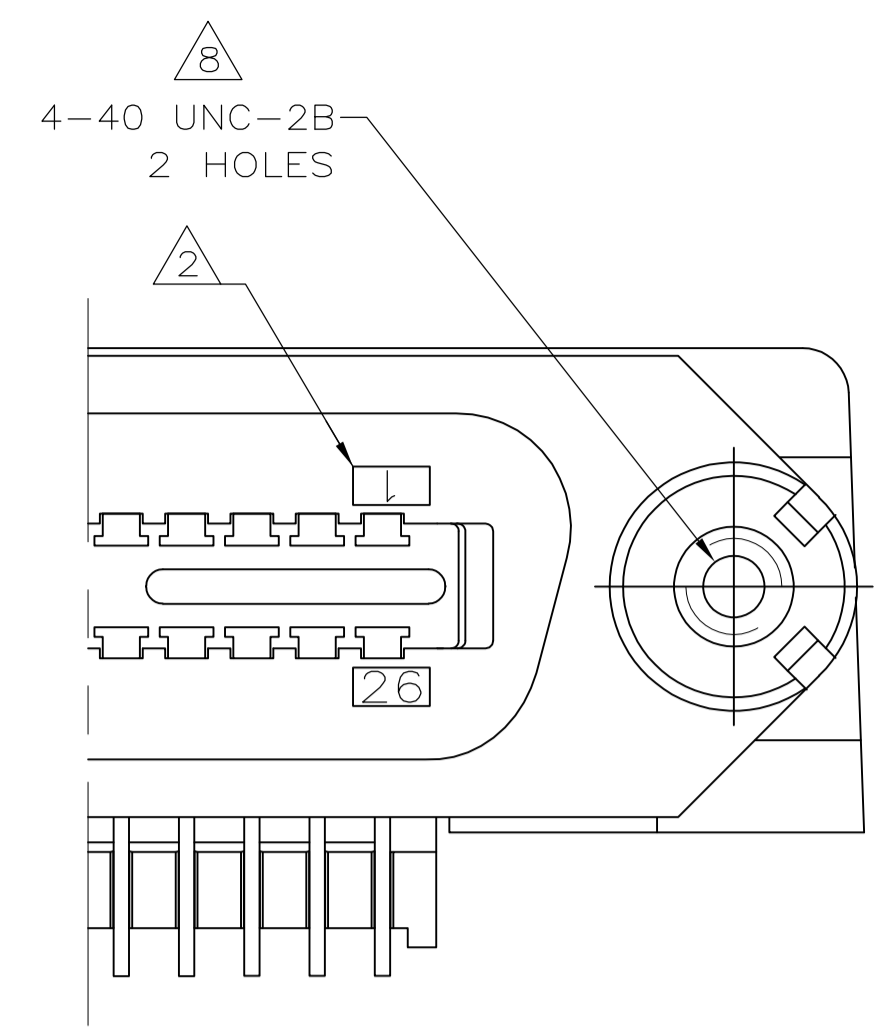

DETAIL A STANDARD ORIENTATION

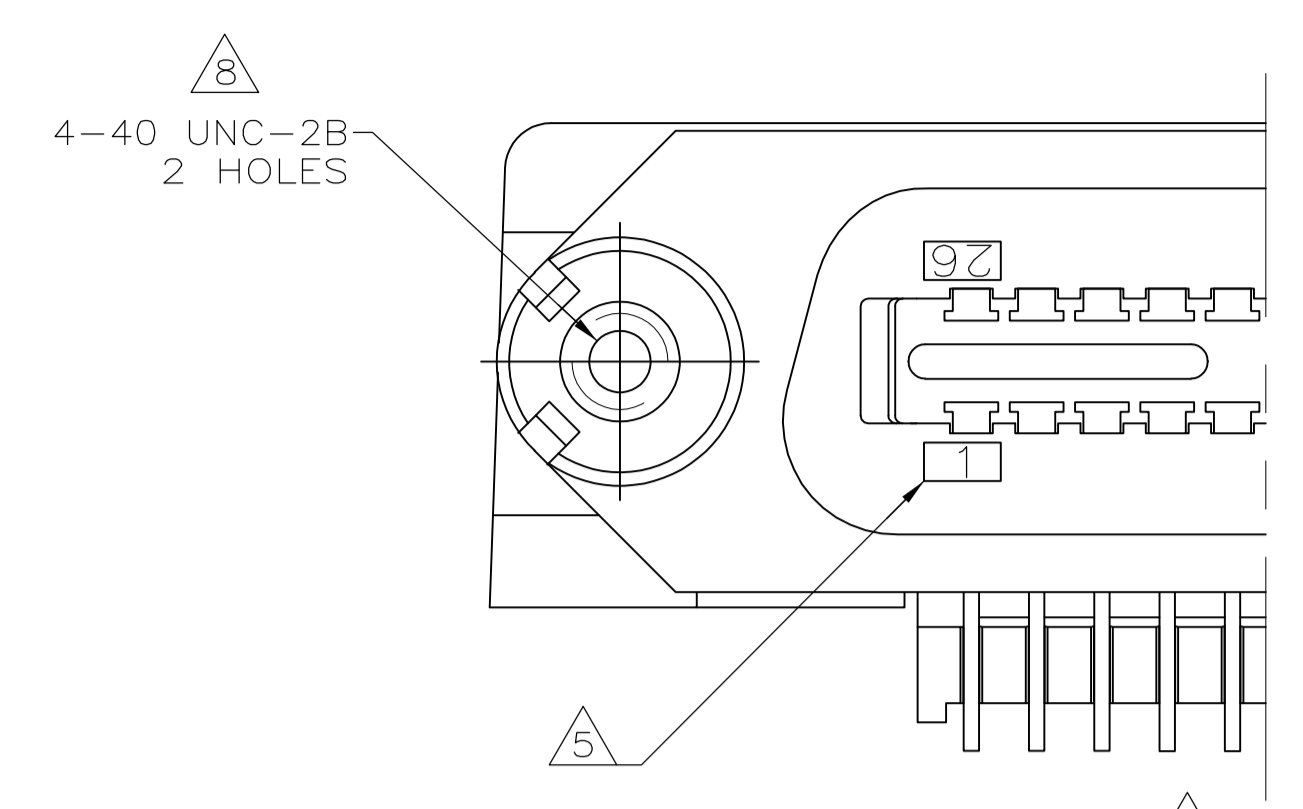

DETAIL B REVERSE ORIENTATION

- △ MATERIAL: HOUSING, BRACKET, PLATE & COMB - THERMOPLASTIC, BLACK, 94V-0 RATED. TERMINALS- HIGH STRENGTH COPPER ALLOY PLATED WITH EITHER 0.76µm [.000030] MIN GOLD PLATE OR GOLD FLASH OVER PALLADIUM NICKEL PLATE, 0.76µm [.000030] MIN TOTAL ON MATING SURFACE. 3.05µm [.000120] MIN TIN ON TAILS. ALL OVER 1.27µm [.000050] MIN NICKEL UNDERPLATE OVER ENTIRE TERMINAL. THREADED INSERT- #4-40 UNC, BRIGHT ZINC PLATED BRASS.
- △ TERMINAL 1 IS LOCATED IN THIS ROW FOR STANDARD ORIENTATION, 5552725-1, -2, -5 & -7.
- △ TERMINAL SUPPORT PLATE CLEARANCE FOR TERMINAL STRAIN RELIEF AND FLUX REMOVAL.
- △ MAXIMUM PANEL THICKNESS: 1.57[.062].
- △ TERMINAL 1 IS LOCATED IN THIS ROW FOR REVERSE ORIENTATION, 5552725-3 AND -6 ONLY.
- △ DETAILS "A" AND "B" ARE VIEWED FROM MATING SIDE OF RECEPTACLE ASSEMBLY.
- △ FOR USE WITH A NO.4 BT TYPE SELF-TAPPING SCREW.
- △ 5552725-1,-2 AND -3 ARE TAPPED 4-40; -5,-6 & -7 USE 4-40 THREADED INSERTS.
- △ INSERT SHALL WITHSTAND 8 INCH-POUNDS OF TORQUE WITHOUT CRACKING HOUSING OR LOOSENING.

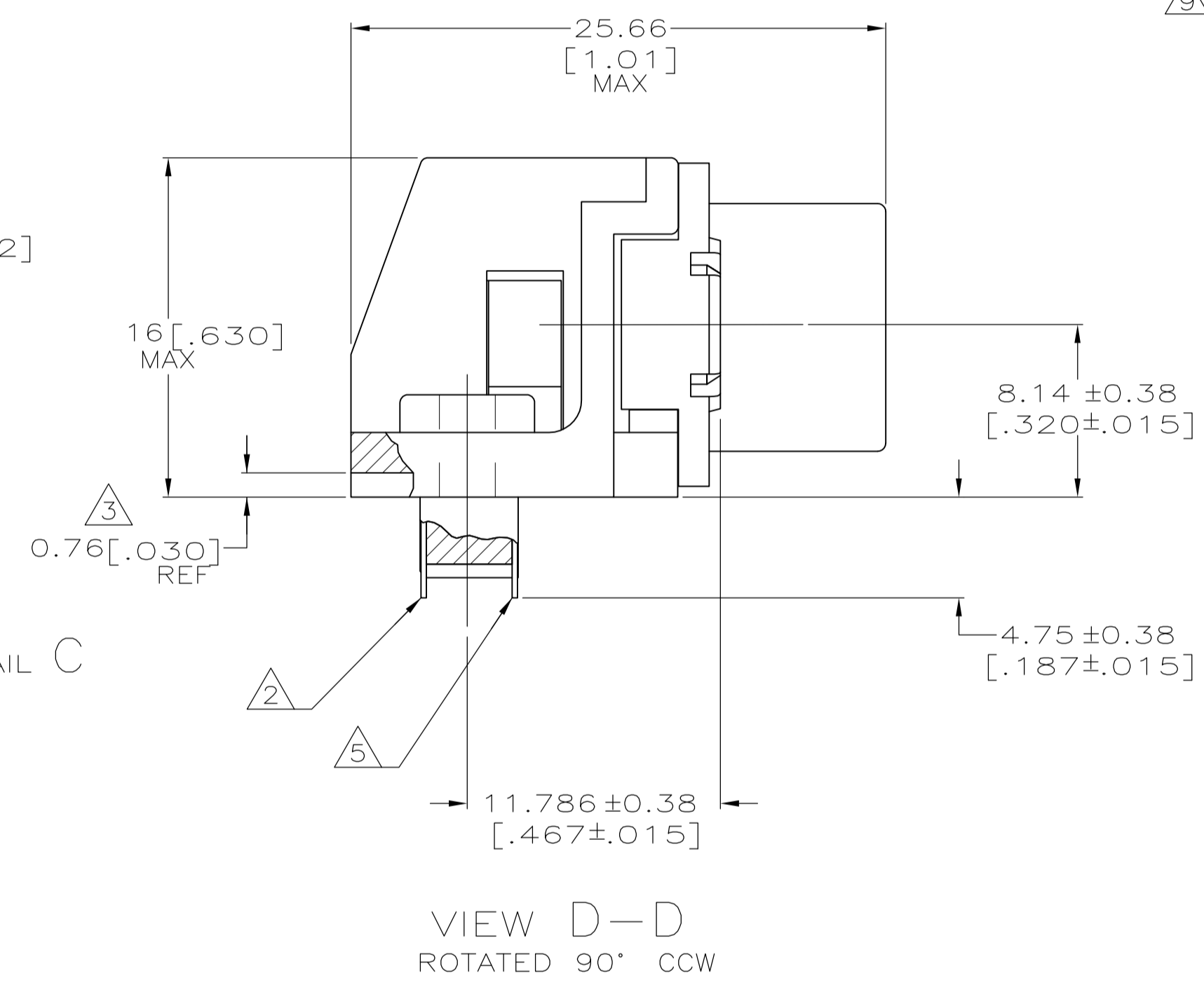
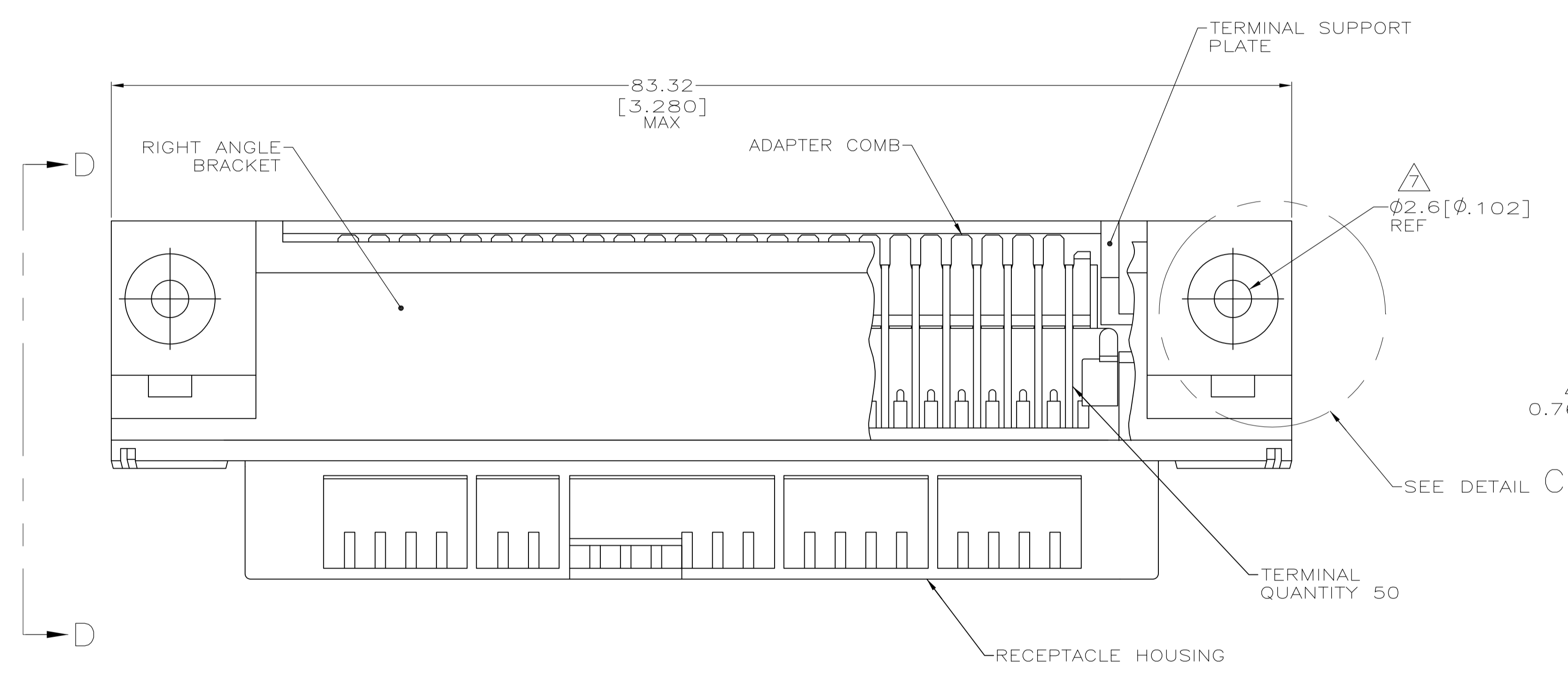

VIEW D-D ROTATED 90° CCW

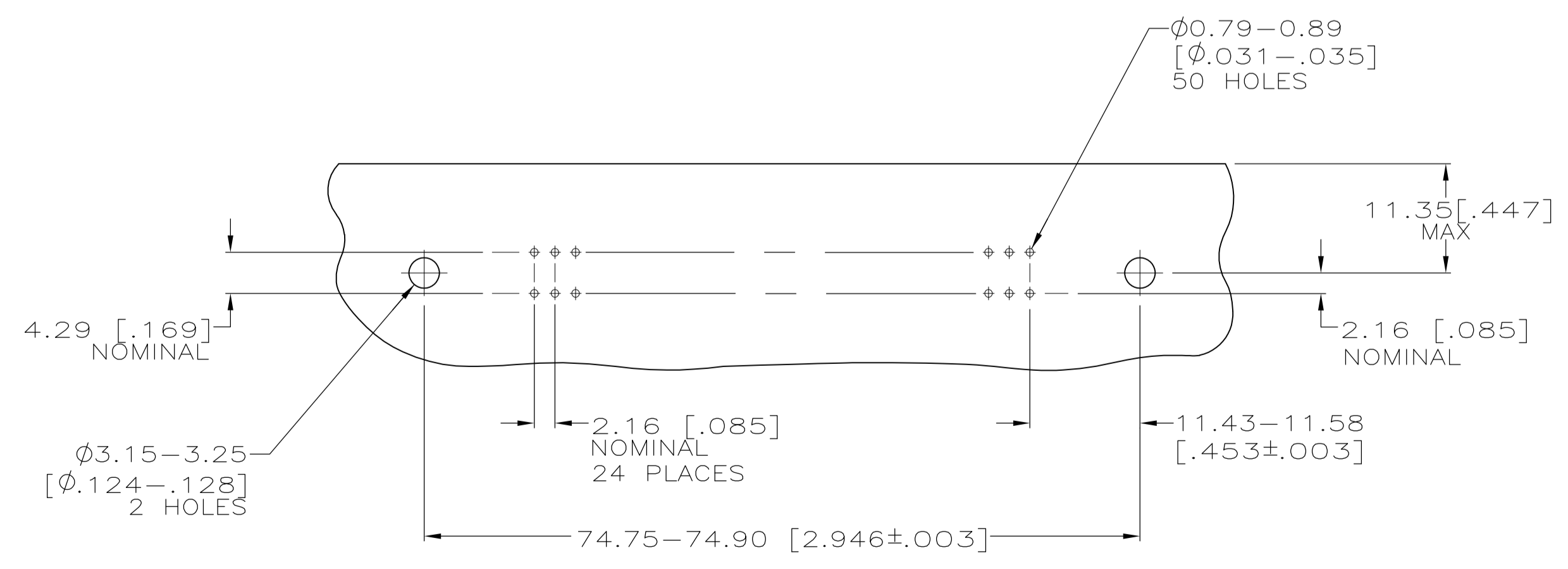

SUGGESTED PRINTED CIRCUIT BOARD MOUNTING DIMENSIONS SCALE 2:1

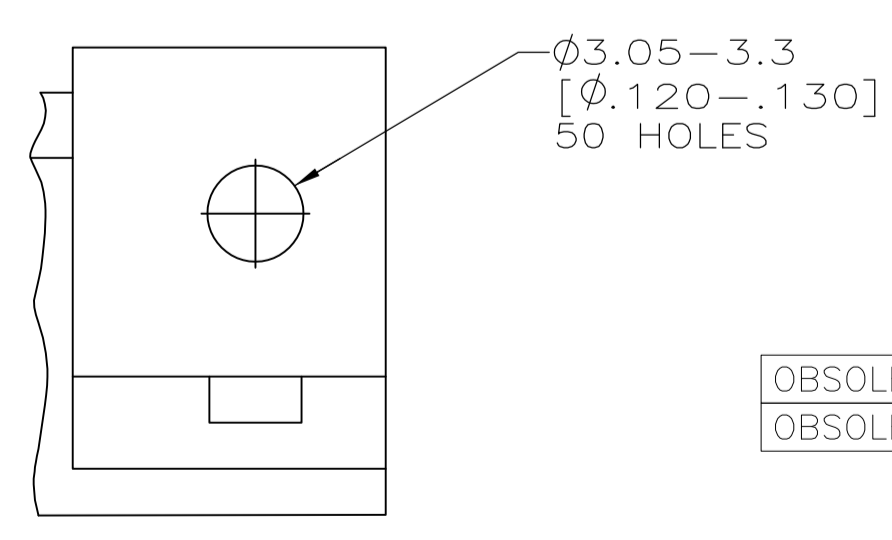

DETAIL C (THRU-BOLT)

OBsolete	THREAD TYPE	TYPE OF MOUNTING	DESCRIPTION	PART NUMBER
OBsolete	THREADED INSERT	THRU-BOLT(SEE DETAIL C)	SEE DETAIL A	5552725-7
OBsolete	THREADED INSERT	SELF-TAPPING	SEE DETAIL B	5552725-6
OBsolete	THREADED INSERT	SELF-TAPPING	SEE DETAIL A	5552725-5
	TAPPED HOLE	SELF-TAPPING	SEE DETAIL B	5552725-3
	TAPPED HOLE	THRU-BOLT(SEE DETAIL C)	SEE DETAIL A	5552725-2
	TAPPED HOLE	SELF-TAPPING	SEE DETAIL A	5552725-1

THIS DRAWING IS A CONTROLLED DOCUMENT.		DL DRUMMOND 18 AUG 97		TE Connectivity	
DIMENSIONS: mm [INCHES]		TOLERANCES UNLESS OTHERWISE SPECIFIED:		RECEPTACLE ASSEMBLY, 50 POSITION, RIGHT ANGLE, SELF TAPPING, CHAMP®	
0 PLC	± .005	1 PLC	± .005	SIZE	A1
1 PLC	± .005	2 PLC	± .005	CAGE CODE	00779
2 PLC	± .005	3 PLC	± 0.13[.005]	DRAWING NO	5552725
3 PLC	± .005	4 PLC	± .005	WEIGHT	
4 PLC	± .005	ANGLES	± .005	CUSTOMER DRAWING	
MATERIAL		FINISH		SCALE 4:1 SHEET 1 OF 1 REV E1	