

Low drop adjustable positive voltage regulator



BA1117FP

●Features

- Low dropout voltage:
 - 1.2 V typ. (at $I_o = 1\text{ A}$, 25°C)
- Output current up to 1 A
- Adjustable version availability ($V_{REF} = 1.25\text{ V}$)
- Internal current and thermal limit
- Available in $\pm 1\%$ (at 25°C) and 2% in full temperature range
- High supply voltage rejection:
 - 75 dB typ. (at 25°C)
- Temperature range: -20°C to 105°C
- Designed to use by ceramic capacitors

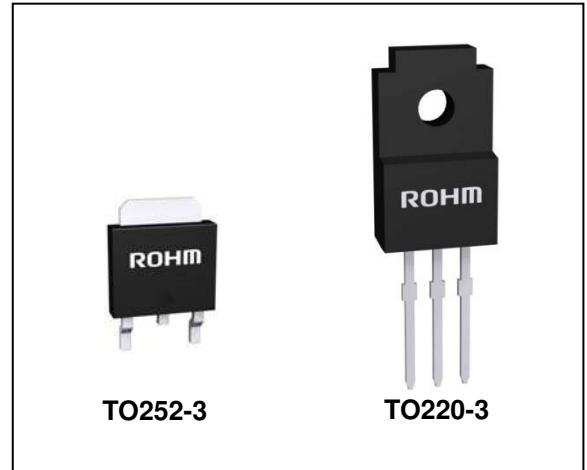

●Description

The BA1117FP is a low drop voltage regulator able to provide up to 1 A of output current, available in adjustable versions ($V_{REF} = 1.25\text{ V}$). The device is supplied in: TO252-3 and TO220-3. Surface mounted packages optimize the thermal characteristics while offering a relevant space saving advantage. High efficiency is assured by NPN pass transistor. Only a very common 22 μF minimum capacitor is needed for stability. Chip trimming allows the regulator to reach a very tight reference voltage tolerance, within $\pm 1\%$ at 25°C.

●Typical Application

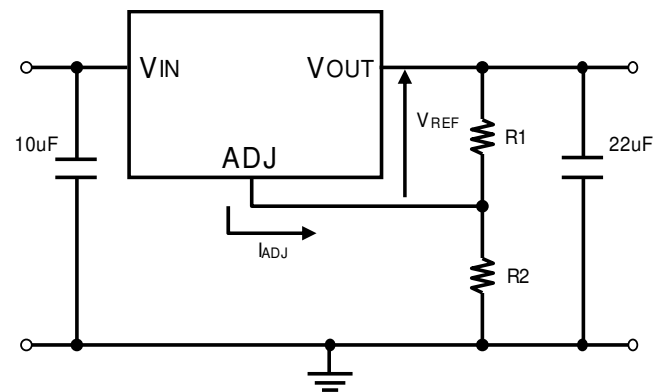

$V_{REF} = 1.25\text{ V (Typ.)}$
 $I_{ADJ} = 60\text{ }\mu\text{A (Typ.)}$
 $V_O = V_{REF} \times (1 + R_2 / R_1) + I_{ADJ} \times R_2$

Table1. Device summary

Order codes		Output voltage
TO252-3	TO220-3	
BA1117FP-E2	Under development	Adjustable from 1.25 V

● Diagram

Figure 1. Block diagram

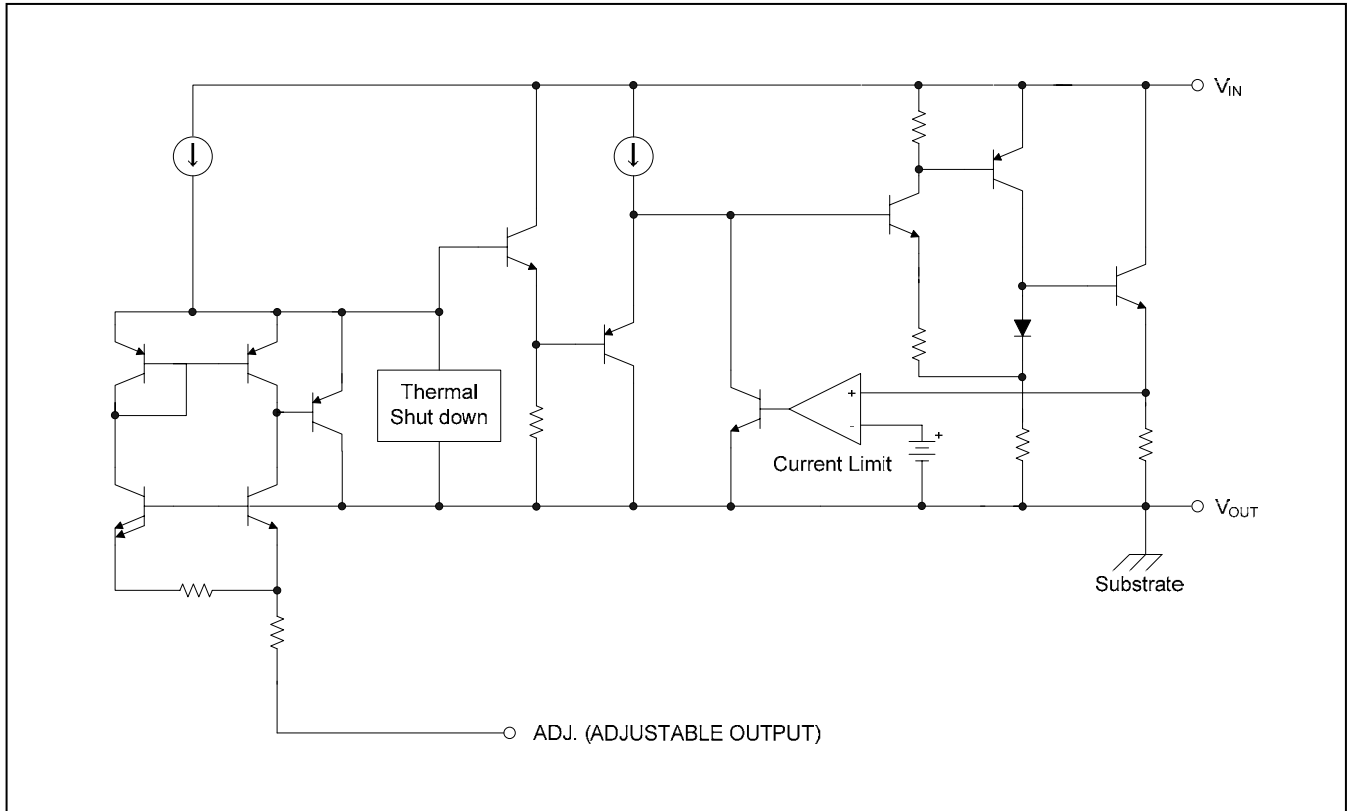

● Pin configuration

Figure 2. Pin connections (top view)

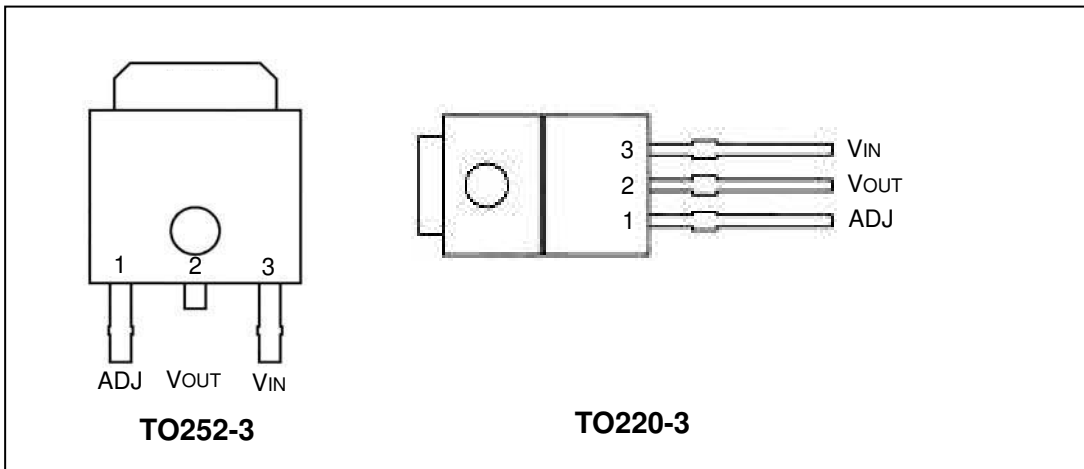

Note1: The TAB is connected to the VOUT.

● Maximum ratings

Table 2. Absolute maximum ratings

Symbol	Parameter	Value	Unit
V _{IN}	DC input voltage	15	V
P _D	Power dissipation	1.2 ^(Note3)	W
T _{STG}	Storage temperature range	-55 to +150	°C
T _{OP}	Operating junction temperature range	-20 to +105	°C

Note2: Absolute maximum ratings are those values beyond which damage to the device may occur. Functional operation under these condition is not implied. Beyond the above suggested max. power dissipation, a short-circuit may permanently damage the device.

Note3: In case $T_a \geq 25^\circ\text{C}$ (70mm × 70mm × 1.6mm when mounted on a glass epoxy board) is reduced by 9.6mW/°C.

Table 3. Thermal data

Symbol	Parameter	T0252-3	T0220-3	Unit
R _{thJA}	Thermal resistance junction-ambient	104.2	67.5	°C/W

● Electrical characteristics

Refer to the test circuits, $T_J = -20$ to 105°C , $C_o = 22\ \mu\text{F}$, $C_i = 10\ \mu\text{F}$, unless otherwise specified.

Table 4. Electrical characteristics of BA1117 (Adjustable)

Symbol	Parameter	Test conditions	Min.	Typ.	Max.	Unit
V_o	Reference Voltage	$V_i = 5.3\ \text{V}$, $I_o = 10\ \text{mA}$, $T_J = 25^\circ\text{C}$	1.238	1.250	1.262	V
V_o	Reference Voltage	$I_o = 10\ \text{mA}$ to $1\ \text{A}$, $V_i = 2.75$ to $10\ \text{V}$	1.225		1.27	V
ΔV_o	Line regulation	$V_i = 2.75\ \text{V}$ to $8\ \text{V}$, $I_o = 0\ \text{mA}$		1	6	mV
ΔV_o	Load regulation	$V_i = 2.75\ \text{V}$, $I_o = 0$ to $1\ \text{A}$		1	10	mV
ΔV_o	Temperature stability			0.5		%
ΔV_o	Long term stability	1000hrs, $T_J = 105^\circ\text{C}$		0.3		%
V_i	Operating input voltage	$I_o = 100\ \text{mA}$			10	V
I_{ADJ}	Adjustment Pin Current	$V_i \leq 10\ \text{V}$		60	120	μA
ΔI_{ADJ}	Adjustment Pin Current Change	$V_i - V_o = 1.4$ to $10\ \text{V}$, $I_o = 10\ \text{mA}$ to $1\ \text{A}$		0.2	5	μA
$I_{O(\min)}$	Minimum Load Current	$V_i = 10\ \text{V}$		1.7	5	mA
I_o	Output current	$V_i - V_o = 5\ \text{V}$, $T_J = 25^\circ\text{C}$	1000	1700		mA
eN	Output noise voltage	$B = 10\ \text{Hz}$ to $10\ \text{kHz}$, $T_J = 25^\circ\text{C}$		100		μV
SVR	Supply voltage rejection	$I_o = 40\ \text{mA}$, $f = 120\ \text{Hz}$ $V_i - V_o = 3\ \text{V}$, $V_{\text{ripple}} = 1\ \text{V}_{\text{PP}}$,	60	75		dB
V_D	Dropout voltage	$I_o = 100\ \text{mA}$		1	1.10	V
		$I_o = 500\ \text{mA}$		1.05	1.15	V
		$I_o = 1\ \text{A}$		1.20	1.40	V
$\Delta V_{O(\text{pwr})}$	Thermal regulation	$T_a = 25^\circ\text{C}$, 30 ms pulse		0.08	0.2	%/W

● Electrical characteristics (reference data)

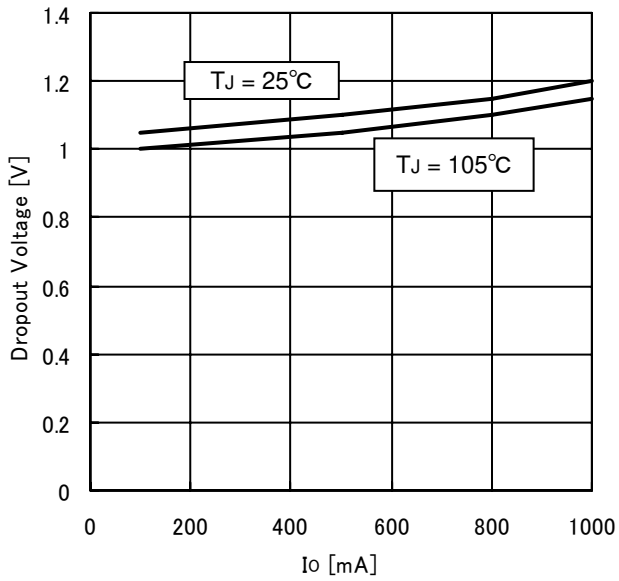

Figure 3. Dropout voltage

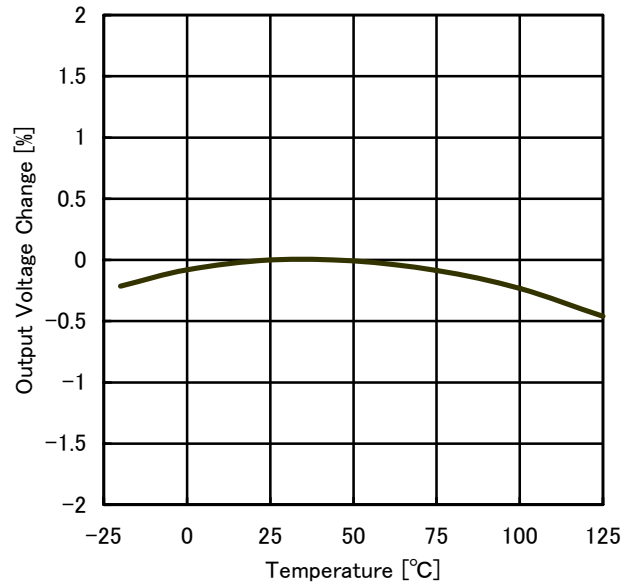

Figure 4. Temperature Stability

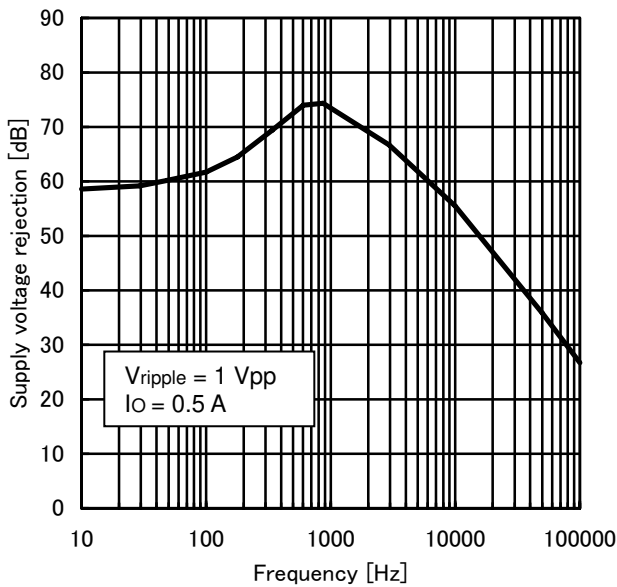

Figure 5. Supply voltage rejection

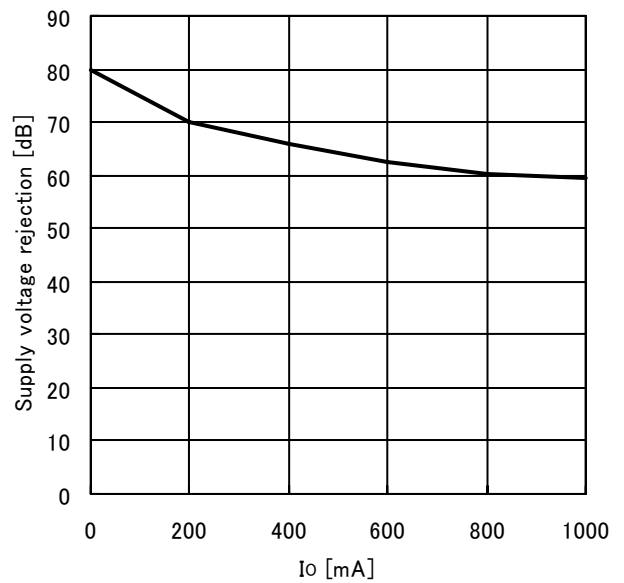

Figure 6. Supply voltage rejection vs I_o

●Electrical characteristics (reference data)

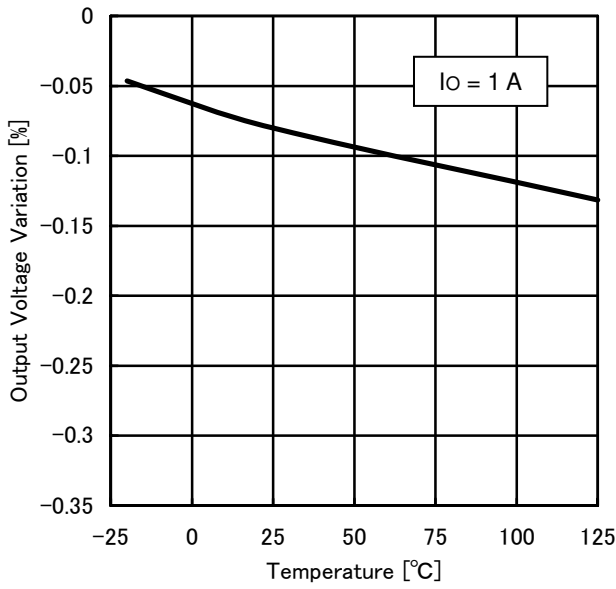

Figure 7. Load regulation

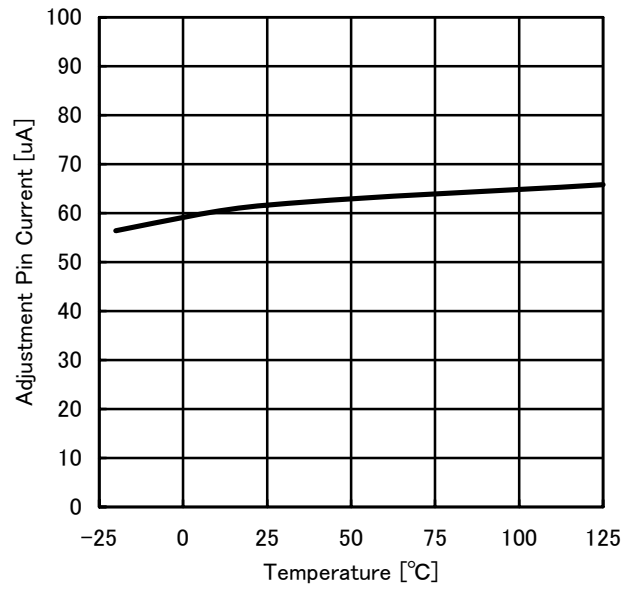

Figure 8. Adjustment pin current

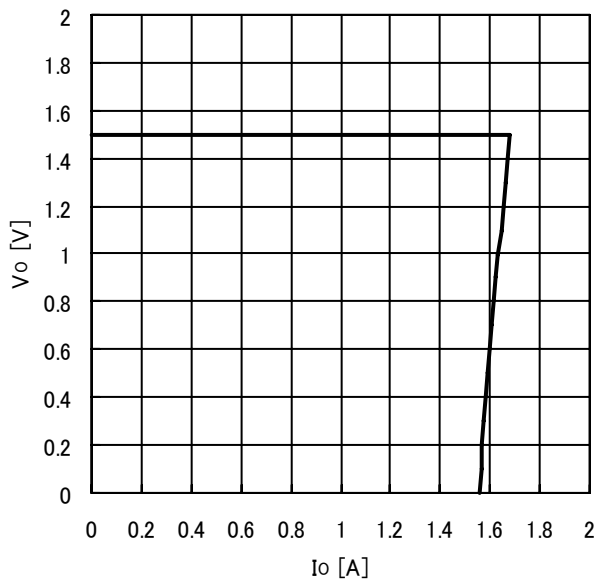

Figure 9. Load regulation vs Vo

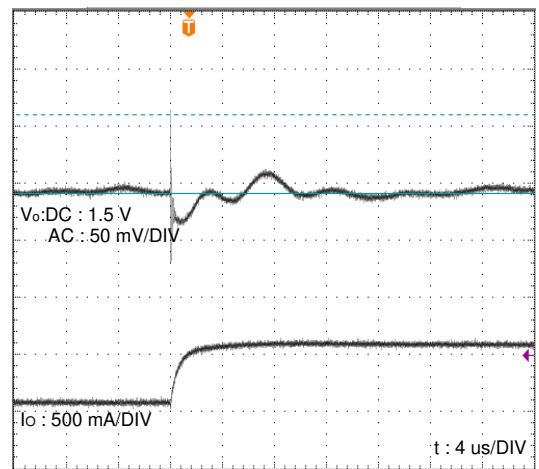

Figure 10. Load Transient Response
(0→0.5A)
Co=22μF

●BA1117 adjustable: application note

The BA1117 adjustable has a thermal stabilized $1.25 \pm 0.012\text{V}$ reference voltage between the V_{OUT} and ADJ pins. I_{ADJ} is $60\mu\text{A}$ typ. ($120\mu\text{A}$ max.) and ΔI_{ADJ} is $0.2\mu\text{A}$ typ ($5\mu\text{A}$ max.). R_1 is normally fixed to 120Ω .

$$V_{\text{O}} = V_{\text{REF}} + R_2 (I_{\text{ADJ}} + I_{\text{R1}}) = V_{\text{REF}} + R_2 (I_{\text{ADJ}} + V_{\text{REF}} / R_1) = V_{\text{REF}} (1 + R_2 / R_1) + R_2 \times I_{\text{ADJ}}$$

In normal applications the R_2 value is in the range of a few $\text{k}\Omega$, so the $R_2 \times I_{\text{ADJ}}$ product can not be considered in the V_{O} calculation; the above expression then becomes:

$$V_{\text{O}} = V_{\text{REF}} (1 + R_2 / R_1).$$

In order to have a better load regulation it is important to realize a good Kelvin connection of R_1 and R_2 resistors. In particular, the R_1 connection must be realized very close to the V_{OUT} and ADJ pins, while the R_2 ground connection must be placed as near as possible to the negative load pin. Ripple rejection can be improved by introducing a $10\mu\text{F}$ electrolytic capacitor placed in parallel to the R_2 resistor (see Figure 11, 12).

The output capacitor is critical in maintaining regulator stability, and must meet the required conditions for both minimum amount of capacitance and ESR (Equivalent Series Resistance). The minimum output capacitance required by the BA1117FP is $22\mu\text{F}$, if a ceramic/tantalum capacitor is used. Any increase of the output capacitance will merely improve the loop stability and transient response. The ESR of the output tantalum capacitor should range between $0.3\Omega - 5\Omega$.

Figure. 11 Adjustable output voltage application

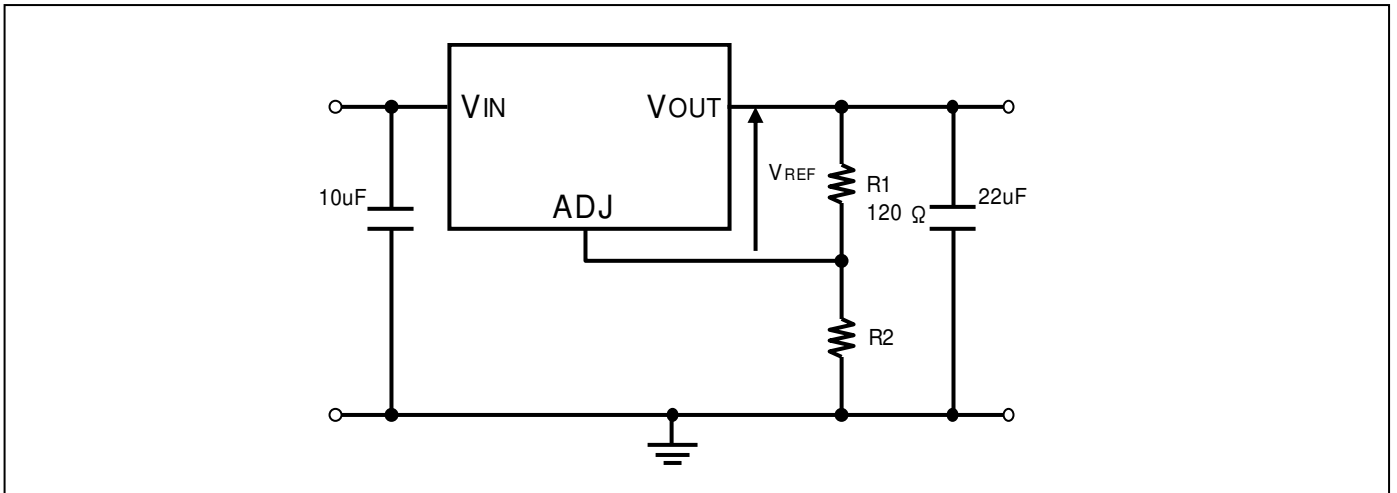
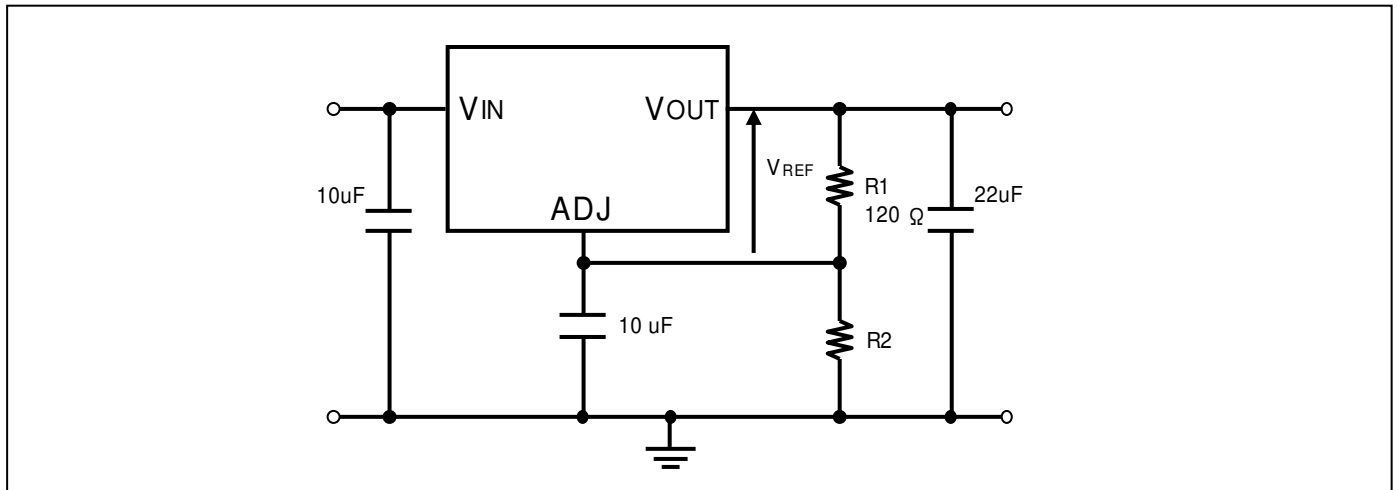

Figure. 12 Adjustable output voltage application with improved ripple rejection



● Input- to-Output Capacitor

It is recommended that a capacitor is placed very close between Input pin and GND, output pin and GND.

A capacitor, between input pin and GND, is valid when the power supply impedance is high or the trace is long. Also as for a capacitor, between output pin and GND, the greater the capacity, more sustainable the line regulation and it makes improvement of the characteristics depending on the load. However, please check the actual functionality of this part by mounting on a board for the actual application. Ceramic capacitor usually have different, thermal and equivalent series characteristics, and moreover capacitance decreases gradually in use.

For additional detail, please check the manufacturer, and select the best ceramic capacitor for your application.

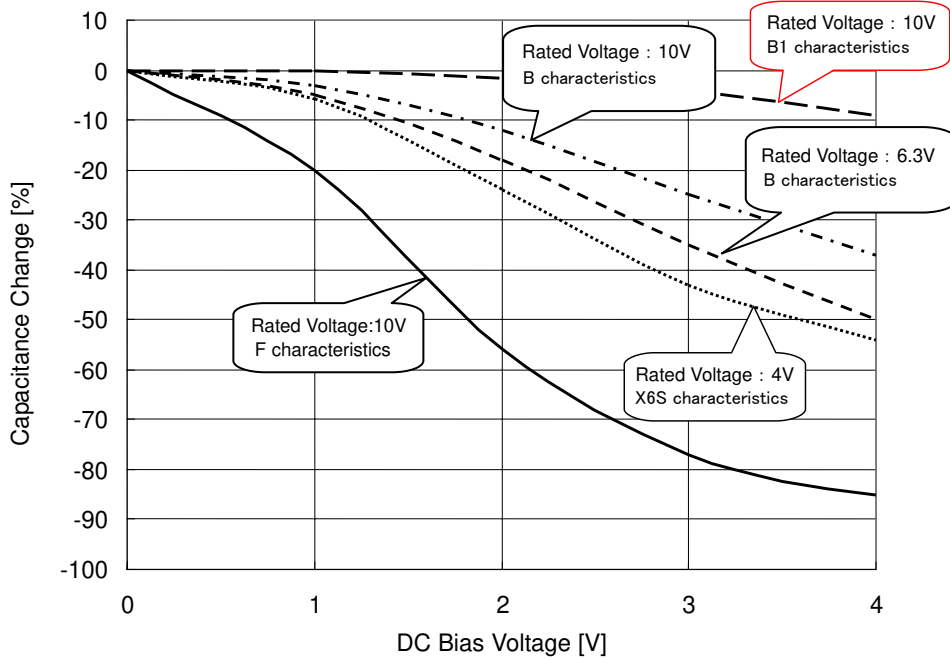

Ceramic capacitor capacity – DC bias characteristics
(Characteristics example)

●Operational Notes

(1). Absolute maximum ratings

An excess in the absolute maximum ratings, such as supply voltage, temperature range of operating conditions, etc., can break down the devices, thus making impossible to identify damage mode, such as a short circuit or an open circuit. If there is any possibility of exposure over the rated values, please consider adding circuit protection devices, such as fuses.

(2). Connecting the power supply connector backward

Connecting of the power supply in reverse polarity can damage IC. Take precautions when connecting the power supply lines. An external direction diode can be added.

(3). Power supply lines

Design PCB layout pattern to provide low impedance GND and supply lines. To obtain a low noise ground and supply line, separate the ground section and supply lines of the digital and analog blocks. Furthermore, for all power supply terminals to ICs, connect a capacitor between the power supply and the GND terminal. When using electrolytic capacitors in the circuit, note that capacitance values are reduced at low temperatures and over time.

(4). GND voltage

The potential of GND pin must be minimum potential under all operating conditions.

(5). Thermal design

Use a thermal design that allows for a sufficient margin in light of the power dissipation (Pd) in actual operating conditions.

(6). Inter-pin shorts and mounting errors

Use caution when positioning the IC for mounting on printed circuit boards. The IC may be damaged if there is any connection error or if pins are shorted together.

(7). Actions in strong electromagnetic field

Use caution when using the IC in the presence of a strong electromagnetic field as this may cause the IC to malfunction.

(8). ASO

When using the IC, set the output transistor so that it does not exceed absolute maximum ratings or ASO.

(9). Thermal shutdown circuit

The IC incorporates a built-in thermal shutdown circuit (TSD circuit). The thermal shutdown circuit (TSD circuit) is designed only to shut the IC off to prevent thermal runaway. It is not designed to protect the IC or guarantee its operation. Do not continue to use the IC after operating this circuit or use the IC in an environment where the operation of this circuit is assumed.

(10). Testing on application boards

When testing the IC on an application board, connecting a capacitor to a pin with low impedance subjects the IC to stress. Always discharge capacitors after each process or step. Always turn the IC's power supply before connecting it or removing it from a jig or fixture during the inspection process. Ground the IC during assembly steps as an antistatic measure. Use similar precaution when transporting or storing the IC.

(11). Regarding input pin of the IC

This monolithic IC contains P+ isolation and P substrate layers between adjacent elements in order to keep them isolated. P-N junctions are formed at the intersection of these P layers with the N layers of other elements, creating a parasitic diode or transistor. For example, the relation between each potential is as follows:

When $V_O > \text{Pin A}$ and $V_O > \text{Pin B}$, the P-N junction operates as a parasitic diode.

When $V_O > \text{Pin B}$, the P-N junction operates as a parasitic transistor.

Parasitic diodes can occur inevitable in the structure of the IC.

The operation of parasitic diodes can result in mutual interference among circuits, operational faults, or physical damage. Accordingly, methods by which parasitic diodes operate, such as applying a voltage that is lower than the V_O (P substrate) voltage to an input pin, should not be used.

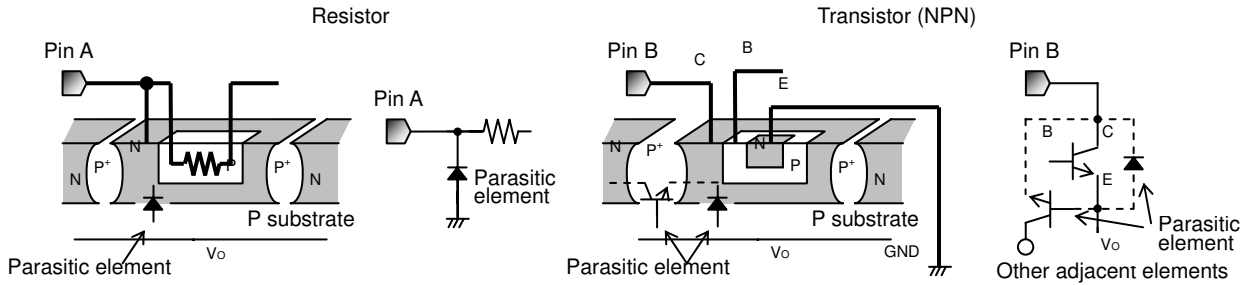

(12). Ground Wiring Pattern.

When using both small signal and large current GND patterns, it is recommended to isolate the two ground patterns, placing a single ground point at the ground potential of application so that the pattern wiring resistance and voltage variations caused by large currents do not cause variations in the small signal ground voltage. Be careful not to change the GND wiring pattern of any external components, either.

● Physical Dimension/Tape and Reel Information

TO252-3

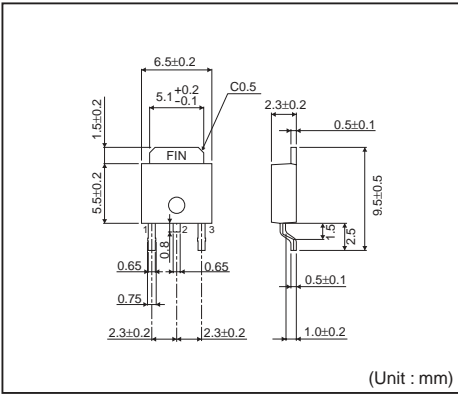

<Tape and Reel information>

Tape	Embossed carrier tape
Quantity	2000pcs
Direction of feed	E2 (The direction is the 1pin of product is at the lower left when you hold reel on the left hand and you pull out the tape on the right hand)

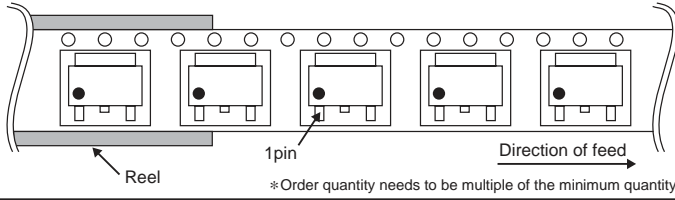

TO220FP-3

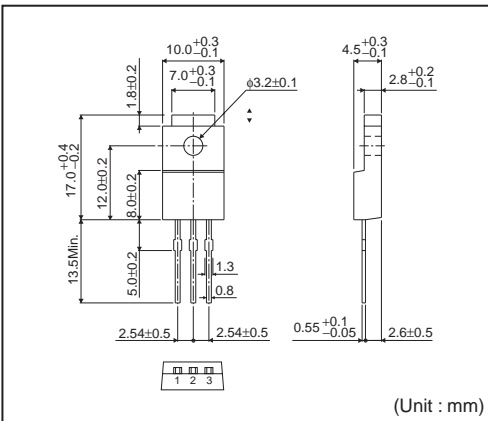

<Tape and Reel information>

Container	Tube
Quantity	500pcs
Direction of feed	Direction of products is fixed in a container tube

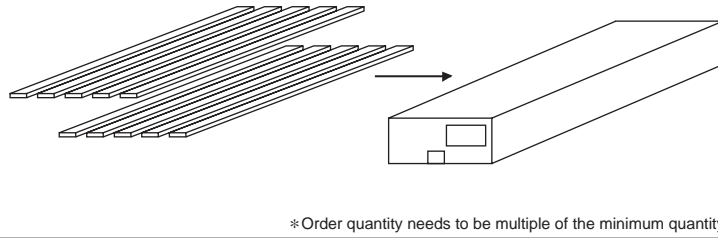

● Marking Diagram

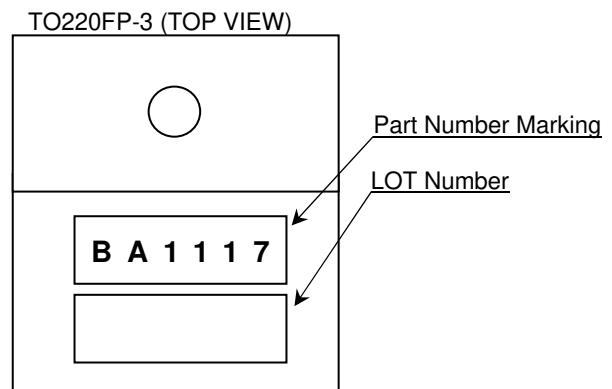
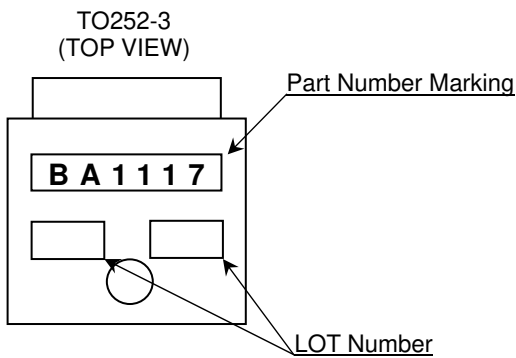

Notice

Precaution on using ROHM Products

- Our Products are designed and manufactured for application in ordinary electronic equipments (such as AV equipment, OA equipment, telecommunication equipment, home electronic appliances, amusement equipment, etc.). If you intend to use our Products in devices requiring extremely high reliability (such as medical equipment ^(Note 1), transport equipment, traffic equipment, aircraft/spacecraft, nuclear power controllers, fuel controllers, car equipment including car accessories, safety devices, etc.) and whose malfunction or failure may cause loss of human life, bodily injury or serious damage to property ("Specific Applications"), please consult with the ROHM sales representative in advance. Unless otherwise agreed in writing by ROHM in advance, ROHM shall not be in any way responsible or liable for any damages, expenses or losses incurred by you or third parties arising from the use of any ROHM's Products for Specific Applications.

(Note1) Medical Equipment Classification of the Specific Applications

JAPAN	USA	EU	CHINA
CLASS III	CLASS III	CLASS II b	CLASS III
CLASS IV		CLASS III	

- ROHM designs and manufactures its Products subject to strict quality control system. However, semiconductor products can fail or malfunction at a certain rate. Please be sure to implement, at your own responsibilities, adequate safety measures including but not limited to fail-safe design against the physical injury, damage to any property, which a failure or malfunction of our Products may cause. The following are examples of safety measures:
 - Installation of protection circuits or other protective devices to improve system safety
 - Installation of redundant circuits to reduce the impact of single or multiple circuit failure
- Our Products are designed and manufactured for use under standard conditions and not under any special or extraordinary environments or conditions, as exemplified below. Accordingly, ROHM shall not be in any way responsible or liable for any damages, expenses or losses arising from the use of any ROHM's Products under any special or extraordinary environments or conditions. If you intend to use our Products under any special or extraordinary environments or conditions (as exemplified below), your independent verification and confirmation of product performance, reliability, etc. prior to use, must be necessary:
 - Use of our Products in any types of liquid, including water, oils, chemicals, and organic solvents
 - Use of our Products outdoors or in places where the Products are exposed to direct sunlight or dust
 - Use of our Products in places where the Products are exposed to sea wind or corrosive gases, including Cl₂, H₂S, NH₃, SO₂, and NO₂
 - Use of our Products in places where the Products are exposed to static electricity or electromagnetic waves
 - Use of our Products in proximity to heat-producing components, plastic cords, or other flammable items
 - Sealing or coating our Products with resin or other coating materials
 - Use of our Products without cleaning residue of flux (even if you use no-clean type fluxes, cleaning residue of flux is recommended); or Washing our Products by using water or water-soluble cleaning agents for cleaning residue after soldering
 - Use of the Products in places subject to dew condensation
- The Products are not subject to radiation-proof design.
- Please verify and confirm characteristics of the final or mounted products in using the Products.
- In particular, if a transient load (a large amount of load applied in a short period of time, such as pulse. is applied, confirmation of performance characteristics after on-board mounting is strongly recommended. Avoid applying power exceeding normal rated power; exceeding the power rating under steady-state loading condition may negatively affect product performance and reliability.
- De-rate Power Dissipation (Pd) depending on Ambient temperature (Ta). When used in sealed area, confirm the actual ambient temperature.
- Confirm that operation temperature is within the specified range described in the product specification.
- ROHM shall not be in any way responsible or liable for failure induced under deviant condition from what is defined in this document.

Precaution for Mounting / Circuit board design

- When a highly active halogenous (chlorine, bromine, etc.) flux is used, the residue of flux may negatively affect product performance and reliability.
- In principle, the reflow soldering method must be used; if flow soldering method is preferred, please consult with the ROHM representative in advance.

For details, please refer to ROHM Mounting specification

Precautions Regarding Application Examples and External Circuits

1. If change is made to the constant of an external circuit, please allow a sufficient margin considering variations of the characteristics of the Products and external components, including transient characteristics, as well as static characteristics.
2. You agree that application notes, reference designs, and associated data and information contained in this document are presented only as guidance for Products use. Therefore, in case you use such information, you are solely responsible for it and you must exercise your own independent verification and judgment in the use of such information contained in this document. ROHM shall not be in any way responsible or liable for any damages, expenses or losses incurred by you or third parties arising from the use of such information.

Precaution for Electrostatic

This Product is electrostatic sensitive product, which may be damaged due to electrostatic discharge. Please take proper caution in your manufacturing process and storage so that voltage exceeding the Products maximum rating will not be applied to Products. Please take special care under dry condition (e.g. Grounding of human body / equipment / solder iron, isolation from charged objects, setting of ionizer, friction prevention and temperature / humidity control).

Precaution for Storage / Transportation

1. Product performance and soldered connections may deteriorate if the Products are stored in the places where:
 - [a] the Products are exposed to sea winds or corrosive gases, including Cl₂, H₂S, NH₃, SO₂, and NO₂
 - [b] the temperature or humidity exceeds those recommended by ROHM
 - [c] the Products are exposed to direct sunshine or condensation
 - [d] the Products are exposed to high Electrostatic
2. Even under ROHM recommended storage condition, solderability of products out of recommended storage time period may be degraded. It is strongly recommended to confirm solderability before using Products of which storage time is exceeding the recommended storage time period.
3. Store / transport cartons in the correct direction, which is indicated on a carton with a symbol. Otherwise bent leads may occur due to excessive stress applied when dropping of a carton.
4. Use Products within the specified time after opening a humidity barrier bag. Baking is required before using Products of which storage time is exceeding the recommended storage time period.

Precaution for Product Label

QR code printed on ROHM Products label is for ROHM's internal use only.

Precaution for Disposition

When disposing Products please dispose them properly using an authorized industry waste company.

Precaution for Foreign Exchange and Foreign Trade act

Since our Products might fall under controlled goods prescribed by the applicable foreign exchange and foreign trade act, please consult with ROHM representative in case of export.

Precaution Regarding Intellectual Property Rights

1. All information and data including but not limited to application example contained in this document is for reference only. ROHM does not warrant that foregoing information or data will not infringe any intellectual property rights or any other rights of any third party regarding such information or data. ROHM shall not be in any way responsible or liable for infringement of any intellectual property rights or other damages arising from use of such information or data.:
2. No license, expressly or implied, is granted hereby under any intellectual property rights or other rights of ROHM or any third parties with respect to the information contained in this document.

Other Precaution

1. This document may not be reprinted or reproduced, in whole or in part, without prior written consent of ROHM.
2. The Products may not be disassembled, converted, modified, reproduced or otherwise changed without prior written consent of ROHM.
3. In no event shall you use in any way whatsoever the Products and the related technical information contained in the Products or this document for any military purposes, including but not limited to, the development of mass-destruction weapons.
4. The proper names of companies or products described in this document are trademarks or registered trademarks of ROHM, its affiliated companies or third parties.

General Precaution

1. Before you use our Products, you are requested to carefully read this document and fully understand its contents. ROHM shall not be in any way responsible or liable for failure, malfunction or accident arising from the use of any ROHM's Products against warning, caution or note contained in this document.
2. All information contained in this document is current as of the issuing date and subject to change without any prior notice. Before purchasing or using ROHM's Products, please confirm the latest information with a ROHM sales representative.
3. The information contained in this document is provided on an "as is" basis and ROHM does not warrant that all information contained in this document is accurate and/or error-free. ROHM shall not be in any way responsible or liable for any damages, expenses or losses incurred by you or third parties resulting from inaccuracy or errors of or concerning such information.