

THIS DRAWING IS UNPUBLISHED. RELEASED FOR PUBLICATION
 © COPYRIGHT - By - ALL RIGHTS RESERVED.

LOC		DIST		REVISIONS			
P	LTR	DESCRIPTION		DATE	DWN	APVD	
IR	-	P		SHIELD RAW MATERIAL CHANGED TO BRASS	07OCT2011	PS	RRP

NOTES:

1. TOLERANCES UNLESS OTHERWISE SPECIFIED: ± 0.15 .
2. FOR APPLICATION INFORMATION SEE SPEC. 114-19019.
3. FOR PERFORMANCE REQUIREMENTS SEE SPEC. 108-19064
4. THIS DIMENSION CONCERNING THE GROUNDING TIPS OF THE SHIELD IS NOT GUARANTEED PRIOR TO MOUNTING ON THE PCB

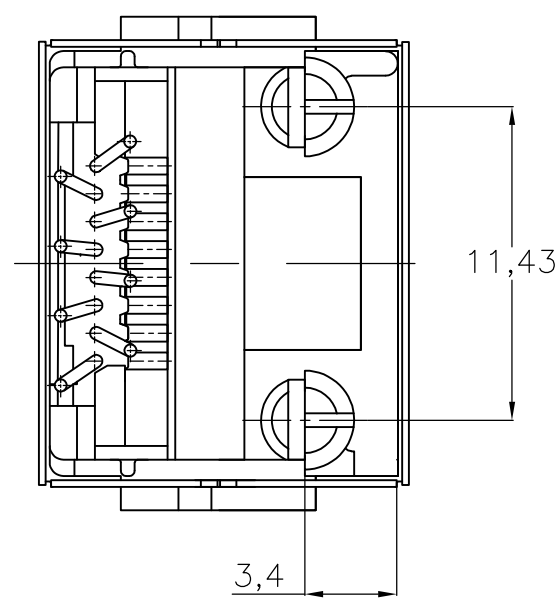
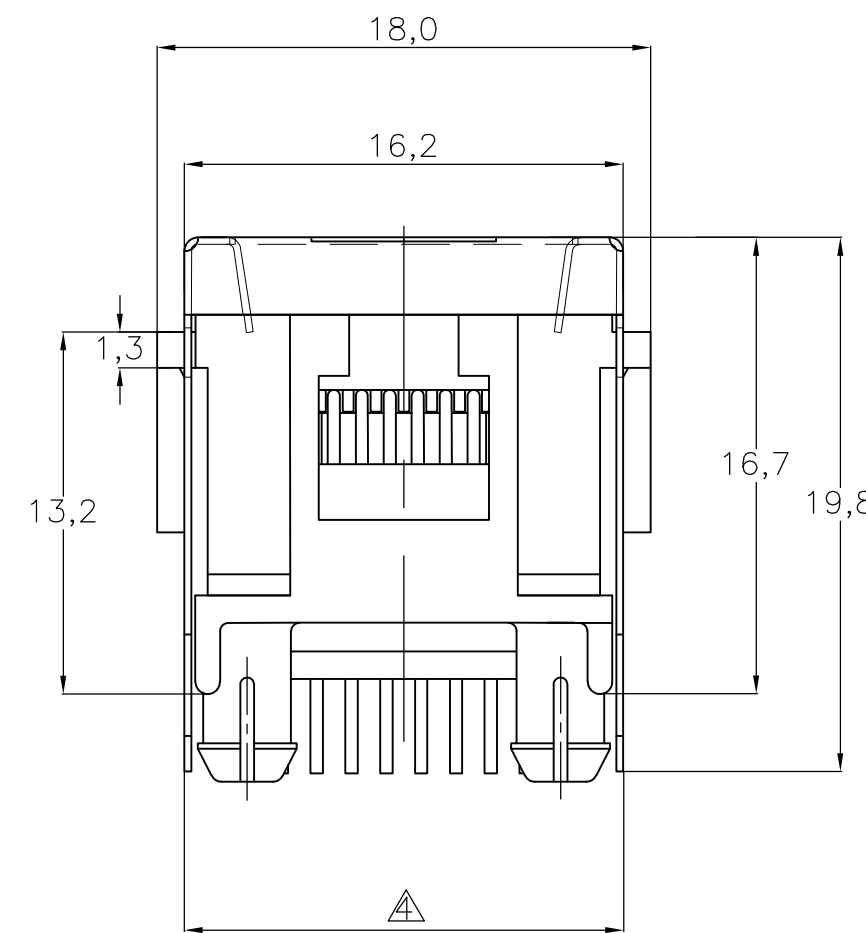
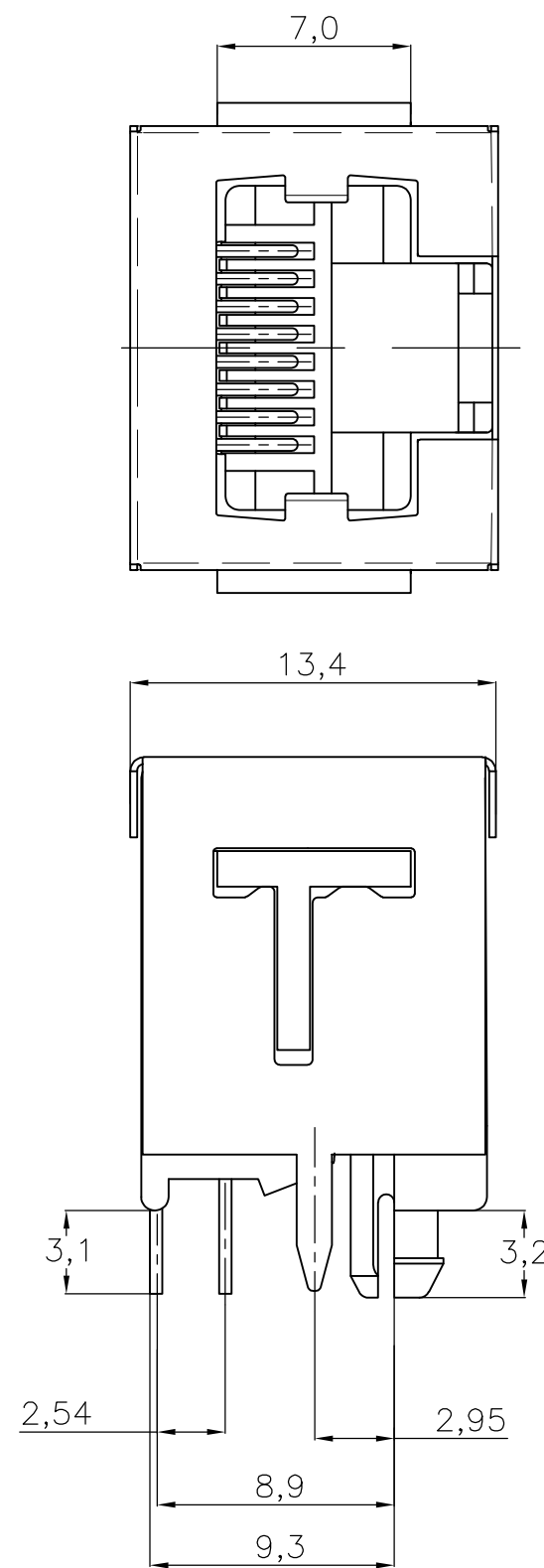
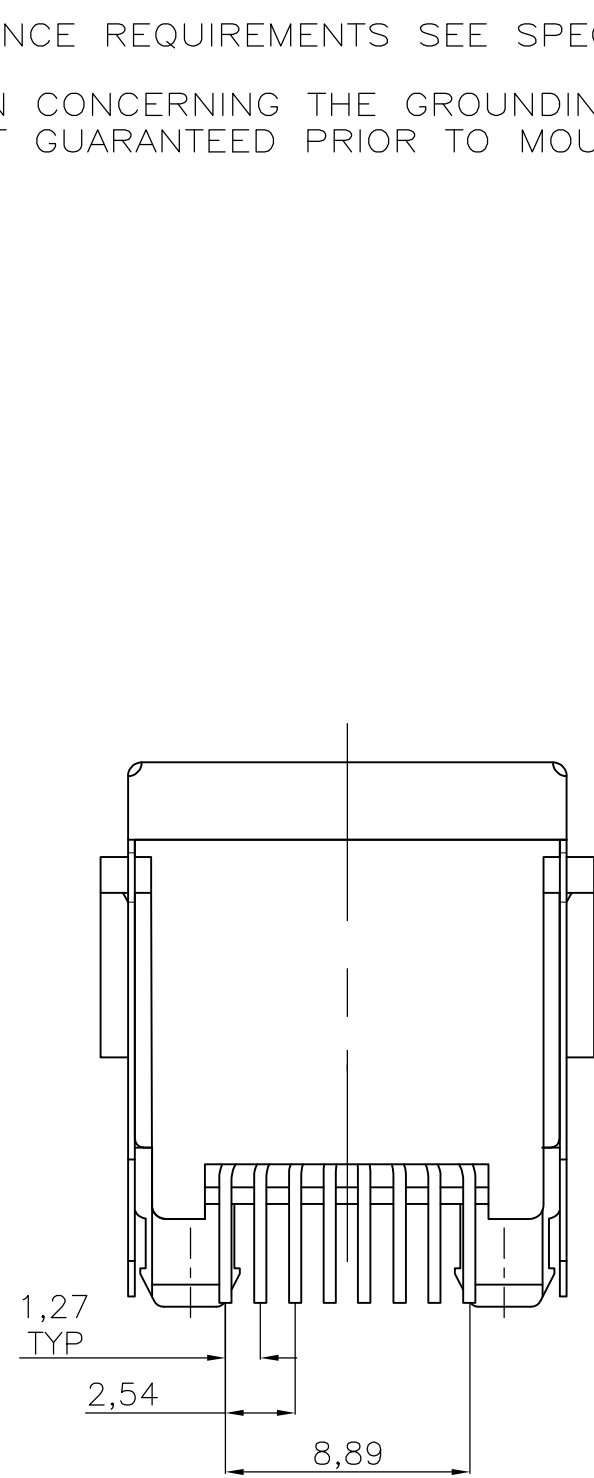

THIS DRAWING IS A CONTROLLED DOCUMENT.		DWN R.HOGEVEEN 03DEC91	TE Connectivity			
DIMENSIONS: mm		CHK W.BRUMMANS 30MAR92				
TOLERANCES UNLESS OTHERWISE SPECIFIED: 0 PLC ± - 1 PLC ± - 2 PLC ± - 3 PLC ± - 4 PLC ± - ANGLES ± - FINISH SEE TABLE		APVD L.v.SOEST 01APR92	NAME MODULAR JACK 8 POS. TOP ENTRY SHIELDED WITH PANEL STOP			
MATERIAL SEE TABLE		PRODUCT SPEC APPLICATION SPEC	SIZE A2	CAGE CODE 00779	DRAWING NO C=100616	RESTRICTED TO -
CUSTOMER DRAWING			SCALE NTS	SHEET 1 of 2	REV P	

THIS DRAWING IS UNPUBLISHED. RELEASED FOR PUBLICATION
 © COPYRIGHT - By - ALL RIGHTS RESERVED.

LOC		DIST		REVISIONS			
P	LTR	DESCRIPTION	DATE	DWN	APVD		
-	-	-SEE SHEET 1-	-	-	-		

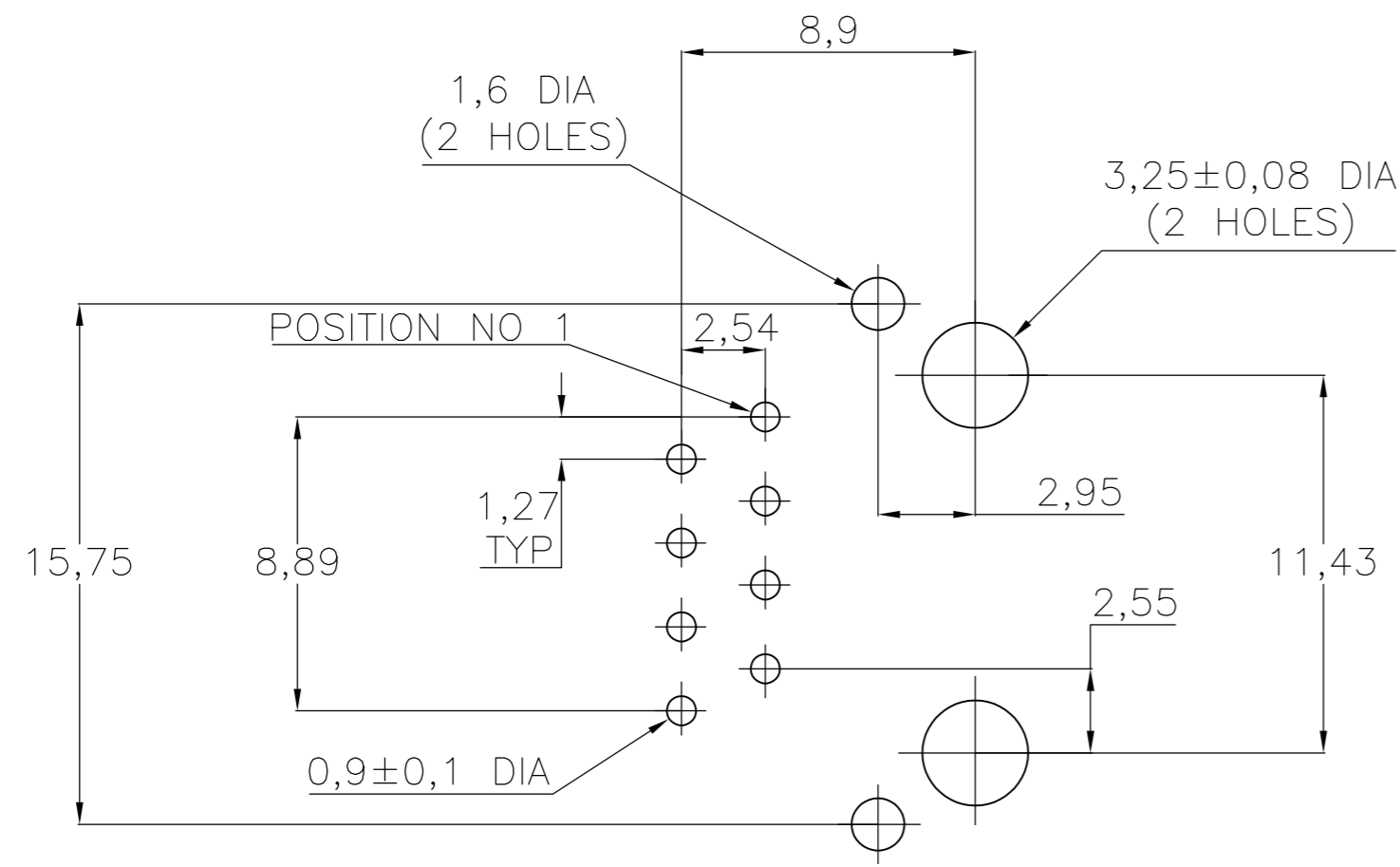

PRINTED CIRCUIT BOARD LAYOUT
 [VIEW SHOWN IS CIRCUIT (NONCOMPONENT) SIDE OF BOARD.]
 TOLERANCES UNLESS OTHERWISE SPECIFIED: ± 0.05
 PRINTED CIRCUIT BOARD THICKNESS: 1,6 mm NOMINAL.

PACKAGING	REMARKS	CONTACT PLATING	MATERIAL	PART NUMBER
BLISTER (1080 pcs, IN A BOX)	8 POSITIONS/ 8 CONTACTS,	<u>IN CONTACT AREA :</u> 1,2µm MIN. SEL. GOLD OVER 1,2µm MIN. NICKEL	<u>HOUSING:</u> PBT,UL 94-VO COLOR: BLACK <u>CONTACTS:</u> PHOSPHOR BRONZE SHIELD: BRASS PRE-PLATED 3-6µm THICK BRIGHT TIN	100616-2
		<u>SOLDER TINES :</u> 2,0µm MIN. TIN OVER 1,2µm MIN. NICKEL	<u>HOUSING:</u> PBT,UL 94-HB COLOR: BLACK <u>CONTACTS:</u> PHOSPHOR BRONZE SHIELD: BRASS PRE-PLATED 3-6µm THICK BRIGHT TIN	100616-1

THIS DRAWING IS A CONTROLLED DOCUMENT.		DWN R.HOGEVEEN 03DEC91	TE Connectivity	
DIMENSIONS: mm		CHK W.BRUMMANS 30MAR92		
TOLERANCES UNLESS OTHERWISE SPECIFIED:		APVD L.v.SOEST 01APR92	NAME MODULAR JACK 8 POS. TOP ENTRY SHIELDED WITH PANEL STOP	
0 PLC ± - 1 PLC ± - 2 PLC ± - 3 PLC ± - 4 PLC ± - ANGLES ± -		PRODUCT SPEC -	SIZE A2	
MATERIAL SEE TABLE		FINISH SEE TABLE	CAGE CODE 00779	DRAWING NO C=100616
		WEIGHT -	RESTRICTED TO -	
		CUSTOMER DRAWING	SCALE -	SHEET 2 of 2