

PRODUCT NO.  
SEE TABLE

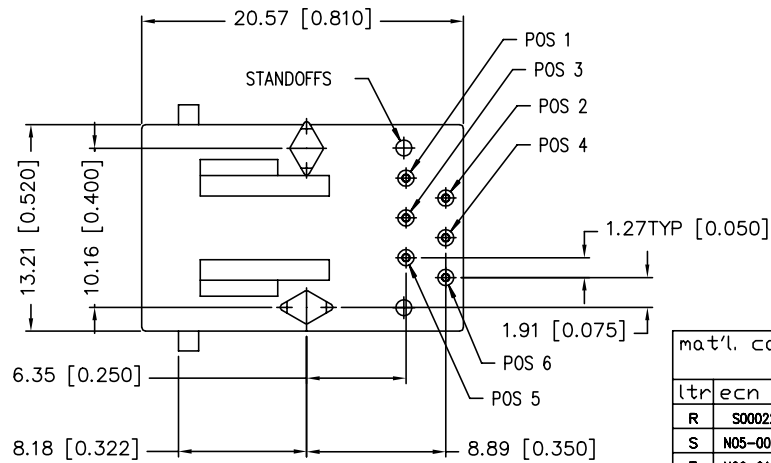

mat'l. code		surface ISO1302 ✓		tolerance ISO1101 ISO406		projection ISO1101		product family MOD JACK	
l	tr	ec	no	dr	date	tolerances unless otherwise specified		title	
R	S00022	BC	L		01/26/00	angle	0.X±0.3	mm	6 POS HORIZONTAL P.C.B. MOD JACK ASSY
S	N05-0002	YS			01/07/05	0°±2'	0.XX±0.15	scale 2.0	
T	N06-0130	LONG			5/15/06		0.XXX±0.05		dwg no
U	N08-0097	SH	MMQ		5/10/08	dr	JANET	01/26/00	sheet 1 of 2
V	ELX-N-010699	SH	MMQ		03/14/12	engr	TONY CHIEN	01/26/00	size A4
						chr	TONY CHIEN	01/26/00	68898
						appd	JENN TSAO	01/26/00	
sheet	revision	v	v						type
index	sheet	1	2						Product Customer Drawing

PRODUCT NO. (NOTE 1)	POSITIONS LOADED	CONTACT PLATING	HOUSING COLOR	EARS	REMARKS
68898-001/-001LF	ALL	5u" Au + high performance lubricant @ TM	BLACK	YES	-
68898-001R/-001RLF	ALL	5u" Au + high performance lubricant @ TM	RED	YES	-
68898-001G/-001GLF	ALL	5u" Au + high performance lubricant @ TM	GREEN	YES	-
-002/-002LF	2,3,4,5	5u" Au + high performance lubricant @ TM	BLACK	YES	-
-003/-003LF	3,4	5u" Au + high performance lubricant	BLACK	YES	-
-004/-004LF	2,3,4,5	5u" Au + high performance lubricant	BLACK	YES	-
-005/-005LF	ALL	5u" Au + high performance lubricant	BLACK	YES	-
-006/-006LF	3,4	5u" Au + high performance lubricant @ TM	BLACK	YES	-
-007	2,3,4,5	GXT @ TM	GRAY	YES	OBSOLETE
-008/-008LF	ALL	5u" Au + high performance lubricant	BLACK	NO	-
-009/-009LF	2,3,4,5	1,27um /50u" GXT	BLACK	YES	-
-010/-010LF	ALL	1,27um /50u" GXT	BLACK	YES	-
-011/-011LF	2,3,4,5	2u" GXT	BLACK	YES	-
-012/-012LF	2,3,4,5	6u" GXT	BLACK	YES	-
-013/-013LF	ALL	5u" Au + high performance lubricant @ TM	BLACK	YES	HI TEMP MATERIAL
-014/-014LF	3,4	6u" GXT	BLACK	YES	-
-015/-015LF	3,4	5u" Au + high performance lubricant @ TM	BLACK	NO	-
-016/-016LF	2,3,4,5	5u" Au + high performance lubricant @ TM	BLACK	NO	-
-017LF	ALL	5u" Au + high performance lubricant @ TM	BLACK	YES	-

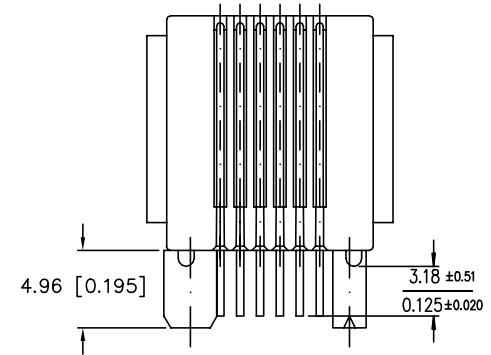
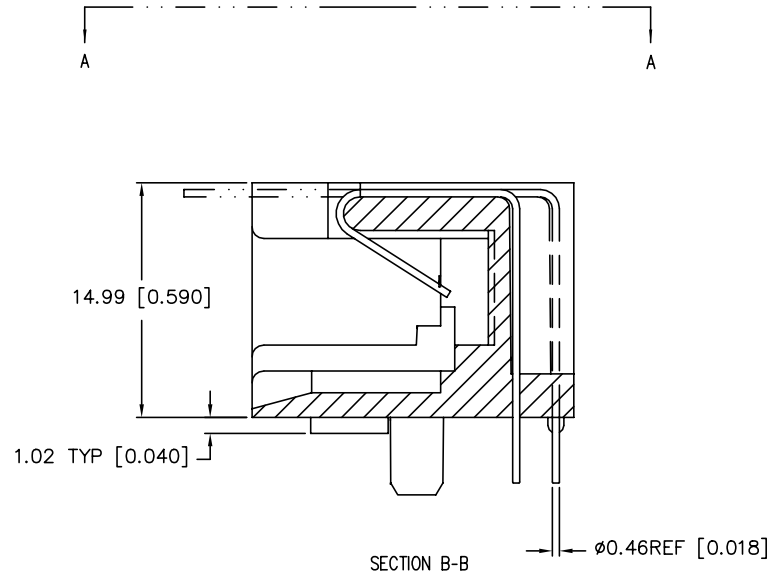
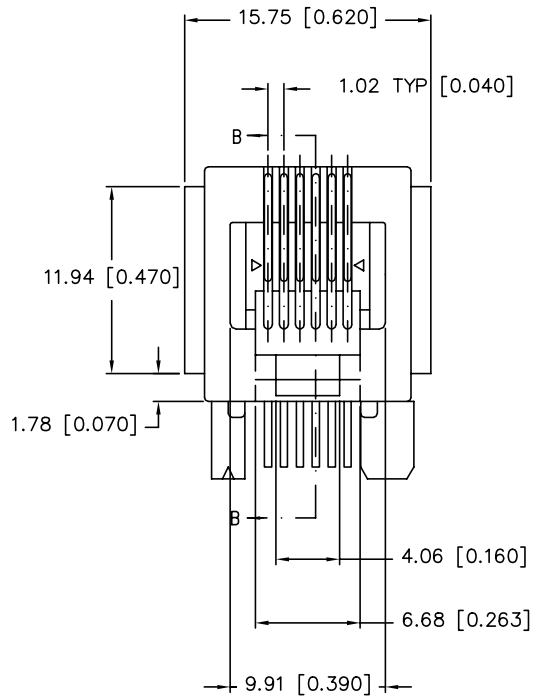
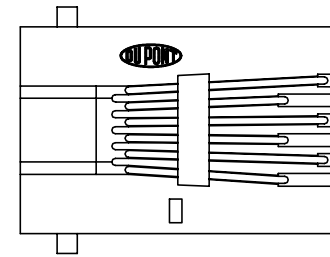

VIEW A-A

NOTES :

- WHEN PRODUCT CALLS FOR PACKAGING IN TRAY ORDER THE PRODUCT WITH PART NUMBER 68898-XXXT OR -XXXTLF FOR PACKAGING IDENTIFICATION. FOR PRODUCT NUMBER WITHOUT SUFFIX "T" OR "TLF", THE PRODUCT WILL BE PACKED IN TUBE AS PER DUPONT STANDARD PACKAGING.
- THIS PRODUCT MEETS EUROPEAN UNION DIRECTIVES AND OTHER COUNTRY REGULATIONS AS DESCRIBED IN GS-22-008.
- IF LF P/N PACKAGING MEETS GS-14-920 SPECIFICATION.
- THE HOUSING WILL WITHSTAND EXPOSURE TO 260°C PEAK TEMPERATURE FOR 10 SECONDS IN A WAVE SOLDER APPLICATION WITH A 1.60mm MINIMUM THICK CIRCUIT BOARD.
- FOR 68898-013/013LF THE HOUSING WILL WITHSTAND EXPOSURE TO 260°C PEAK TEMPERATURE FOR 10 SECONDS IN A CONVECTION, INFRA-RED OR VAPOR PHASE REFLOW OVEN.
- EQUIVALENT THICKNESS Au AND GXT PLATING HAVE SAME FUNCTION AND THEY ARE ALTERNATIVE BY THE CUSTOMER .

A

A

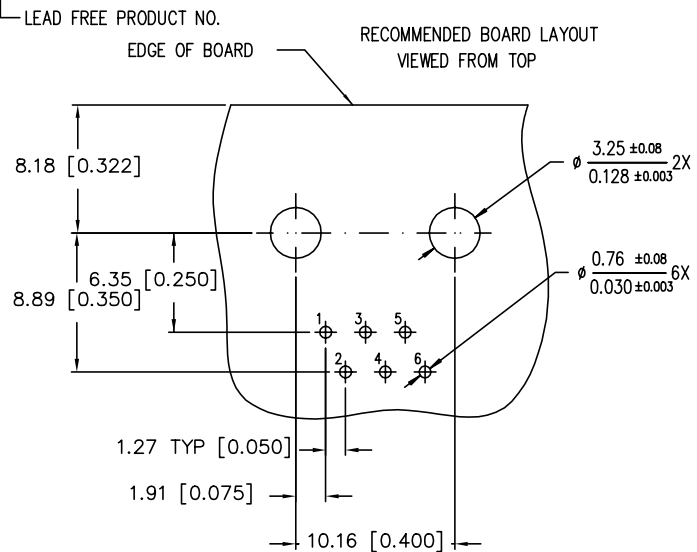

B

mat'l. code	surface ISO1302	tolerance ISO1101 ISO406	projection ISO 1101	product family MOD JACK
l trechn nodr date	tolerances unless otherwise specified	mm	scale 2.0	title 6 POS HORIZONTAL P.C.B. MOD JACK ASSY
R S00022 BC L 01/26/00	angle 0°	0.X±0.3		dwg no
S N05-0002 YS 01/07/05	0°±2'	0.XX±0.15		sheet 2 of 2
T N06-0130 LONG 5/15/06		0.XXX±0.05		size A4
U N08-0097 SH MNO 5/10/08	dr JANET	01/26/00		68898
V ELX-N-010693 SH MNO 03/14/12	engr TONY CHIEN	01/26/00		Product Customer Drawing
	chr TONY CHIEN	01/26/00		
	appd JENN TSAO	01/26/00		
sheet index	revision sheet			



B