

NOTES

1. MATERIAL : BRASS 0.40±0.03 THK'
2. FINISH : POST-TIN PLATING
3. RECOMMENDED LENGTH OF WIRE STRIP IS 5.3-5.8

MATERIAL NO.	PART NO.	W1	H1	W2	H2	WIRE	INSUL.DIA.
357253910	35725-3910	3.1	3.8	4.9	5.6	AWG# 18-#16	MAX.Ø 3.12
357254910	35725-4910			6.5	6.35	AWG# 14	MAX.Ø 3.50 (B1)

WIRE : UL1015

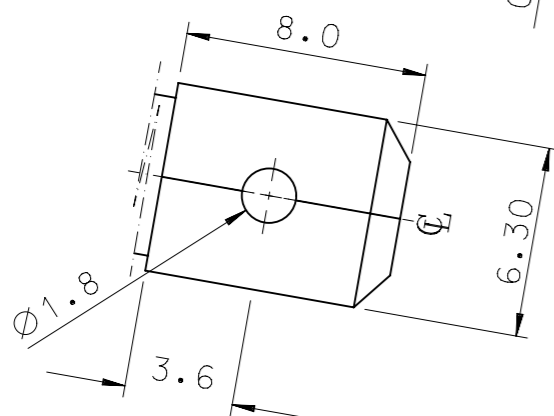

THIS DRAWING CONTAINS INFORMATION THAT IS PROPRIETARY TO MOLEX ELECTRONIC TECHNOLOGIES, LLC AND SHOULD NOT BE USED WITHOUT WRITTEN PERMISSION									
DIMENSION UNITS		SCALE		CURRENT REV DESC: OBSOLETE PART NO					
mm		4:1							
GENERAL TOLERANCES (UNLESS SPECIFIED)									
		MM	INCH	EC NO: 628886 DRWN: VLOKESHA 2019/10/14 CHK'D: GGA 2020/01/13 APPR: GGA 2020/01/13 INITIAL REVISION: DRWN: W.Y.YANG 1993/06/26 APPR: C.W.LEE 1993/06/26					
4 PLACES	±								
3 PLACES	±								
2 PLACES	±	0.3							
1 PLACE	±	0.2							
0 PLACES	±			DOCUMENT NUMBER		DOC TYPE	DOC PART	REVISION	
ANGULAR TOL		± 1.0°		SD-35725-X910		PSD	001	B2	
DRAFT WHERE APPLICABLE MUST REMAIN WITHIN DIMENSIONS		THIRD ANGLE PROJECTION		DRAWING	SERIES	MATERIAL NUMBER	CUSTOMER	SHEET NUMBER	
				A3-SIZE	35725	SEE TABLE	GENERAL MARKET	1 OF 1	