

PART NUMBER	REVISION	DESCRIPTION	FEED TYPE
2151457-1	C	FINE CRIMP HEIGHT ADJUST	MECHANICAL
2151457-2	C	FINE CRIMP HEIGHT ADJUST	PNEUMATIC
7-2151457-1	C	MECHANICAL AND CRIMP TOOLING KIT	MECHANICAL
7-2151457-2	C	PNEUMATIC AND CRIMP TOOLING KIT	PNEUMATIC
7-2151457-7	A	CRIMP TOOLING KIT	-

ATLANTIC VERSION TERMINATOR INTERFACE ADAPTER



APPLICATOR DATA		
CRIMP	SIZE	TYPE
WIRE	2.41 mm [.095]	F
INSUL	4.39 mm [.173]	O

APPLICATOR INSTRUCTIONS
408-35042

TERMINAL DATA: DELPHI TERMINAL		DELPHI CRIMP SPECIFICATION	
TERMINAL NAME: TAXI TERMINAL M/P 280			
WIRE STRIP LENGTH		INSULATION DIAMETER RANGE	
5.20-6.00 mm [1.205-.236 IN]		∅	
TERMINAL APPLICATION SPECIFICATION	DELPHI	-	-

TERMINAL DATA: DELPHI TERMINAL		TE CRIMP SPECIFICATION	
TERMINAL NAME: TAXI TERMINAL M/P 280			
WIRE STRIP LENGTH		INSULATION DIAMETER RANGE	
5.20-6.00 mm [1.205-.236 IN]		∅	
TERMINAL APPLICATION SPECIFICATION	NONE	-	-

TE TERMINAL	DELPHI TERMINAL	TE SEAL	DELPHI SEAL	CABLE DIAMETER
286755-1	12048159	1949092-1	15324985	1.60-2.15
		1949807-1	15324982	2.03-2.85
		1572716-1	12010293	2.81-3.49
		1572716-3	15324980	2.81-3.49
		1572757-1	12015323	2.03-2.85

TE TERMINAL	DELPHI TERMINAL	TE SEAL	DELPHI SEAL	CABLE DIAMETER
286755-1	12048159	1949092-1	15324985	1.60-2.15
		1949807-1	15324982	2.03-2.85
		1572716-1	12010293	2.81-3.49
		1572716-3	15324980	2.81-3.49
		1572757-1	12015323	2.03-2.85

WIRE SIZE	CRIMP HEIGHT mm [INCH]	CRIMP HEIGHT REFERENCE SETTING
1.00mm2	1.40 +/- 0.05 [1.055 +/- .002]	6.8
0.80mm2	1.30 +/- 0.05 [1.051 +/- .002]	7.9
0.50mm2	1.20 +/- 0.05 [1.047 +/- .002]	8.9

WIRE SIZE	CRIMP HEIGHT mm [INCH]	CRIMP HEIGHT REFERENCE SETTING
16 AWG OR 1.25mm2	1.48 +/- 0.05 [1.058 +/- .002]	7.6

- 1. RECOMMENDED SPARE PARTS
 - 2. REFER TO SUPPLIED INSTRUCTION SHEET FOR CLEANING, LUBRICATION AND STORAGE OF APPLICATOR.
 - 3. APPLY PART NUMBER 2-23419-6 LOCTITE TO THREADS OF ITEM 242.
 - 4. CRIMP HEIGHT REFERENCE SETTING WAS THE SETTING USED WHEN THE APPLICATOR WAS QUALIFIED AT THE FACTORY. ADJUSTMENT MAY BE NECESSARY WHEN RUNNING APPLICATOR IN THE FIELD.
 - 5. APPLY TORO-SEAL IN ALLEN SOCKET TO FILL HOLE AFTER FLAT HD HAS BEEN ADJUSTED TO CORRECT HEIGHT AT QUALIFICATION. APPLY #1-23419-5 LOC-TITE TO THREADS.
 - 6. UNLESS SPECIFIED OTHERWISE TORQUE VALUES SHALL BE USED PER DOCUMENT, 101-35000.
7. This crimp parameter is provided to meet a custom and unique customer requirement. It has been evaluated and is conditionally specified by TE Connectivity. This customized crimp parameter is not listed as an approved application within the terminal manufacturer's specifications. **TE Connectivity expressly disclaims any and all warranties that the product will perform similarly to validated and approved applications, as stated within the manufacturer's application specifications, including but not limited to implied warranties of merchantability or fitness for particular purpose.** As such, it is highly recommended that the customer perform further detailed evaluation to assess product performance in the specific application and obtain approval from terminal manufacturer for this custom requirement.

***WARNING**
ON INSTALLATION, SET WIRE DISC TO CRIMP HEIGHT REFERENCE SETTING FOR LARGEST WIRE SIZE. CRIMP HEIGHT REFERENCE SETTINGS GREATER THAN THE VALUE SHOWN MAY CAUSE DAMAGE TO THE CRIMP TOOLING. REFER TO THE INSTRUCTION SHEET FOR PROPER SETUP AND ADJUSTMENTS.

LOC	DIST	REVISIONS					
		P	LTN	DESCRIPTION	DATE	DWN	APVD
A	66			RELEASED	30MAY2014	KH	UG
		B		ECR-18-007491	15MAY2018	TB	JDG
		B1		ECR-18-012120	30JUL2018	AW	TE
		C		ECR-23-162541	03JAN2023	LG	RK

-	1	-	1	-	2119641-1	FEED CAM, AIR FEED	248
-	1	1	1	1	2119082-2	CAM, SNAIL, INSULATION ADJUSTMENT	244
-	1	1	1	1	2079764-1	WASHER, WAVE SPRING, CREST-TO-CREST	243
-	1	1	1	1	2119083-1	RETAINER, INSULATION DIAL	242
-	1	1	1	1	7-18023-7	SCR, SKT HD CAP M3 X 4.0	241
-	-	1	-	1	2119580-1	MECHANICAL FEED ASSEMBLY	239
-	1	-	1	-	2844940-1	AIR FEED MODULE	238
-	REF	REF	REF	REF	994970-2	COUNTER, MAGNETIC	164
-	1	1	1	1	2844908-1	SCREW, LOCKING	99
-	1	1	1	1	2844907-1	POST, LOCKING	98
-	1	1	1	1	318563-1	GUARD, FRONT CHIP	89
-	1	1	1	1	455888-6	SPACER, CRIMPER	82
-	1	1	1	1	1803096-1	EXTENSION PLATE	78
-	1	1	1	1	1803607-3	DOCUMENTATION PACKAGE	71
-	1	1	1	1	2119740-1	TAG, IDENTIFICATION	67
-	2	2	2	2	2168078-1	SCREW, DRIVE, RH, RoHS, 2 x .188	66
-	1	1	1	1	2168083-2	SCR, SKT HD CAP, RoHS, M4 X 8.0	60
-	1	1	1	1	5-18022-5	SCR, HEX HD CAP, M4 X 6.0	59
-	1	1	1	1	985575-3	SCR, FLT SKT HD CAP M3 X 10.0	57
-	1	1	1	1	1338685-1	PAWL, FEED	56
-	4	4	4	4	2168083-3	SCR, SKT HD CAP, RoHS, M4 X 12.0	54
-	2	2	2	2	2168083-8	SCR, SKT HD CAP, RoHS, M4 X 16	53
-	1	1	1	1	5018030-1	NUT, HEX, REG, RoHS, M3	52
-	1	1	1	1	811242-5	BUMPER, HOLD DOWN	51
-	1	1	1	1	690753-2	SPACER, TONKER	50
-	1	2	1	2	18023-9	SCR, SKT HD CAP M4 X 6.0	49
-	-	1	-	1	2119652-1	FEED CAM, PRE FEED	48
-	-	1	-	1	2119653-1	FEED CAM, POST FEED	47
-	1	1	1	1	1803583-9	APPLICATOR BASIC ASSEMBLY, SF	46
-	1	1	1	1	1803515-1	RAM ASSEMBLY, SF ATLANTIC	44
-	1	1	1	1	1803602-1	SCR, BHSC, RoHS (M8 X 25)	41
-	1	1	1	1	1752356-3	SUPPORT, TERMINAL	34
-	2	2	2	2	2079383-5	SCR, BHSC, RoHS (M4 X 20)	33
-	2	2	2	2	1-2844962-7	SPACER, CYLINDRICAL, STRIP GUIDE	30
-	1	1	1	1	2844992-1	ASSEMBLY, STRIP GUIDE	29
-	1	1	1	1	455888-3	SPACER, CRIMPER	28
-	1	1	1	1	1320928-4	STRIP GUIDE	24
-	1	1	1	1	2168083-2	SCR, SKT HD CAP, RoHS, M4 X 8.0	21
-	1	1	1	1	1-18028-2	WASHER, FLAT, REG M4	20
-	1	1	1	1	2119533-1	STRIPPER, SIDE FEED	19
-	1	1	1	1	2119806-1	INSERT, SHEAR	13
-	1	1	1	1	3-22280-3	SPRING, COMPRESSION	12
-	1	1	1	1	1-356885-4	STOP, SHEAR	11
-	1	1	1	1	2119805-1	SHEAR HOLDER, FRONT	10
-	1	1	1	1	318707-1	FLOATING SHEAR, FRONT	9
-	1	2	2	1	1633905-7	ANVIL, COMBINATION	8
-	1	1	1	1	240641-4	SPACER	7
-	-	-	-	-	-	-	6
-	1	1	1	1	2119781-1	DEPRESSOR, SHEAR	5
-	1	1	1	1	238011-2	BLOCK, CRIMPER SPACER	4
-	1	2	2	1	4-1633965-2	CRIMPER, INSULATION O PREMIUM	3
-	1	1	1	1	455888-6	SPACER, CRIMPER	2
-	1	2	2	1	7-1490019-5	CRIMPER, WIRE PREMIUM	1

ATLANTIC VERSION
Shown on sheets 1 of 4 & 2 of 4
(Pacific version shown on sheets 3 of 4 & 4 of 4)

DIMENSIONS:		TOLERANCES UNLESS OTHERWISE SPECIFIED:		MATERIAL:		FINISH:	
mm	0 PLC ±	1 PLC ±	2 PLC ±	3 PLC ±	4 PLC ±	ANGLES ±	FINISH ±

OWN	H. HUANG	06JUN2012	TE Connectivity
CHK			Harrisburg, PA 17105-3608
APVD	S. XI	06JUN2012	
PRODUCT SPEC	Ocean Side Feed Applicator		
APPLICATION SPEC			
SIZE	CAGE CODE	DRAWING NO	RESTRICTED TO
A1	00779	2151457	
Customer Accessible Production Drawing			SCALE 1:2 SHEET 1 OF 4 REV C

LOC	DIST	REVISIONS					
A	66	P	LTN	DESCRIPTION	DATE	OWN	APVD
		-		SEE SHEET 1	-	-	-

FEED TYPE MECHANICAL

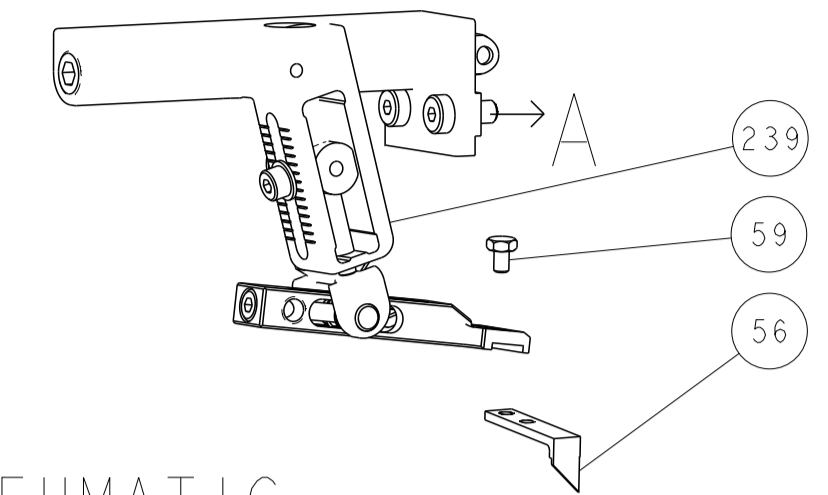

PNEUMATIC

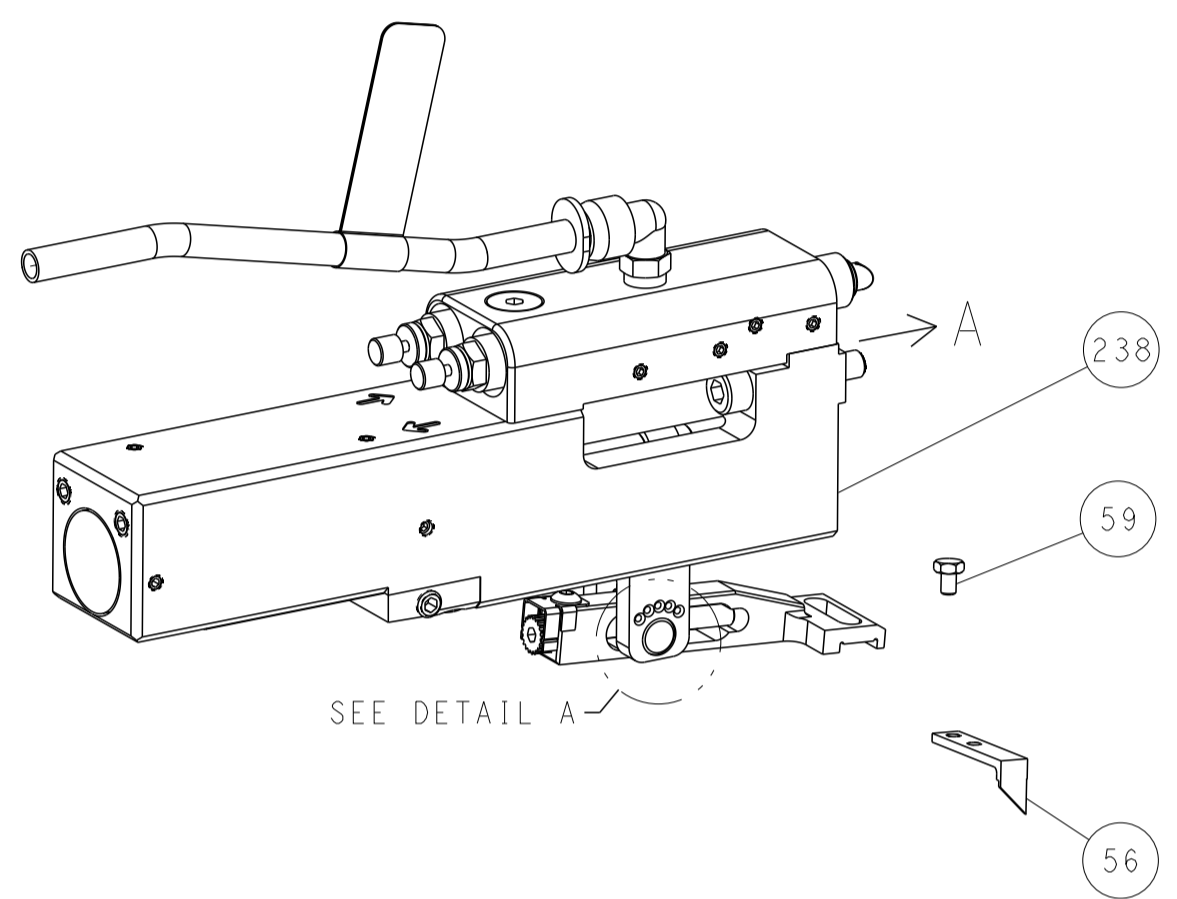

FEED SPRING SETTING POSITION (SHOWN FROM REAR SIDE)

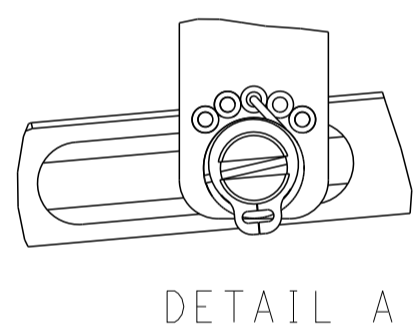

DETAIL A

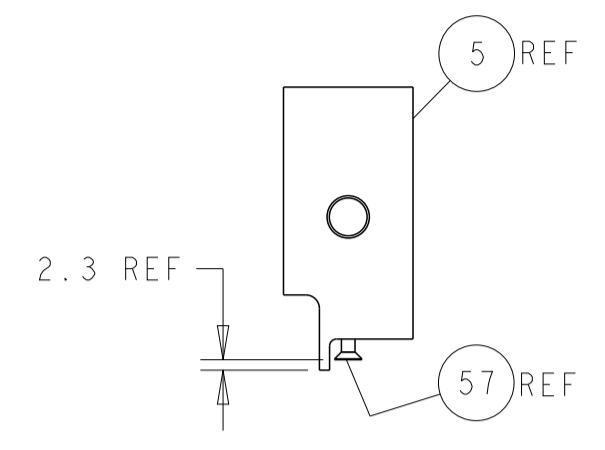
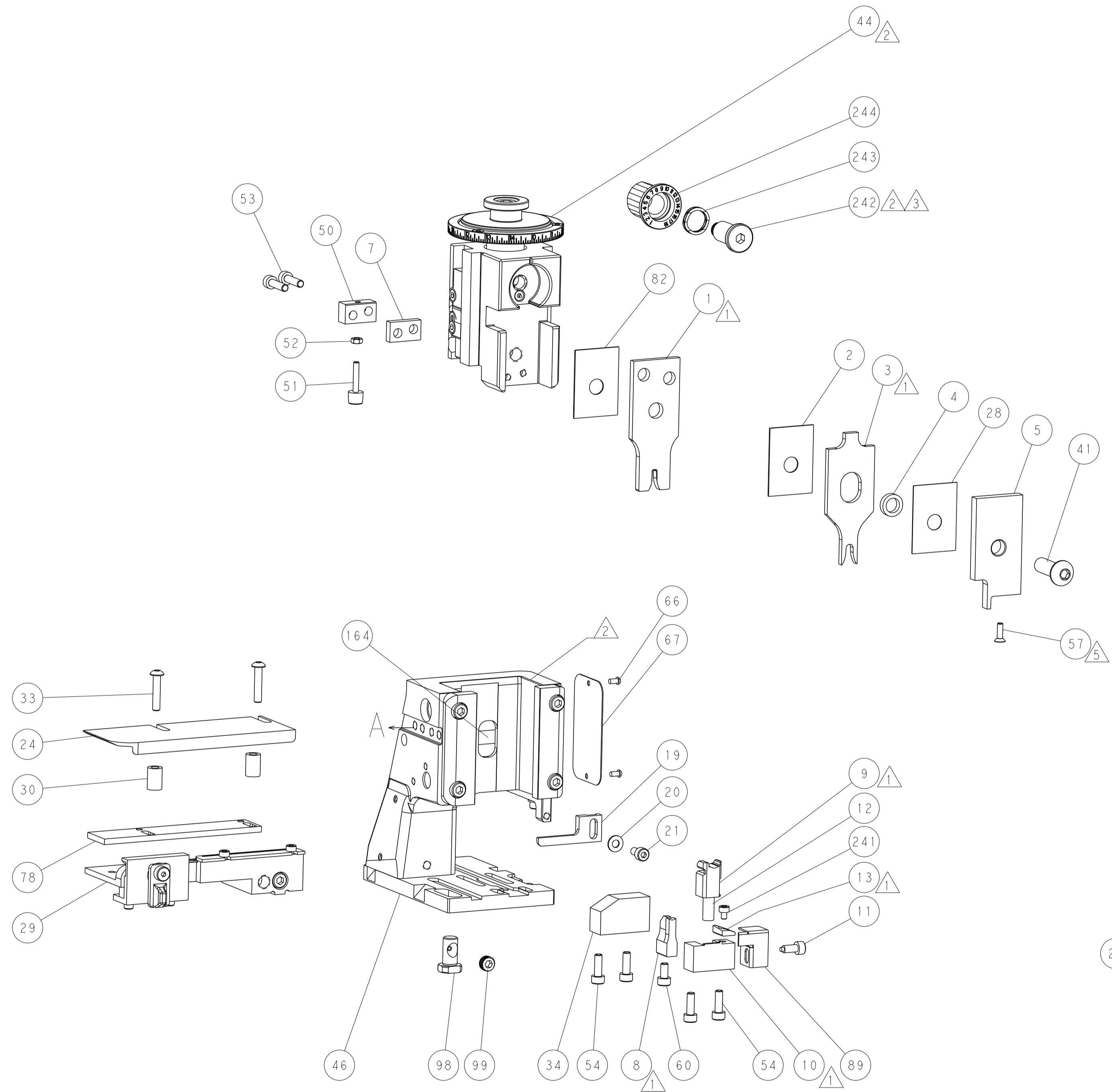

SHEAR DEPRESSOR DETAIL

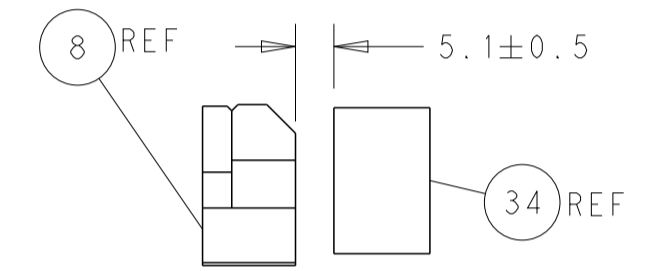

TERMINAL SUPPORT LOCATION

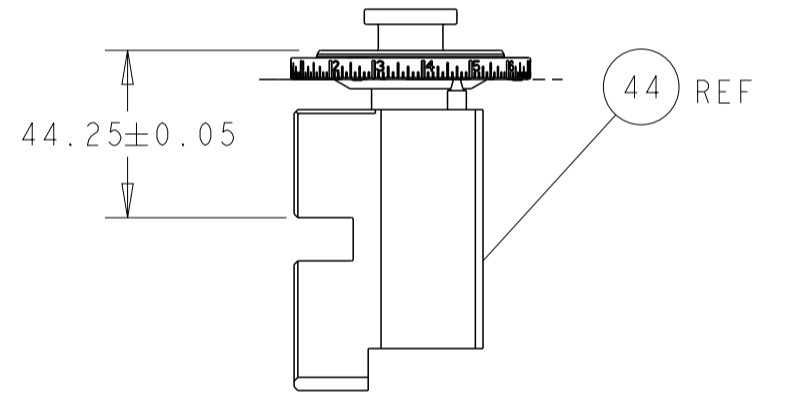

RAM SET-UP

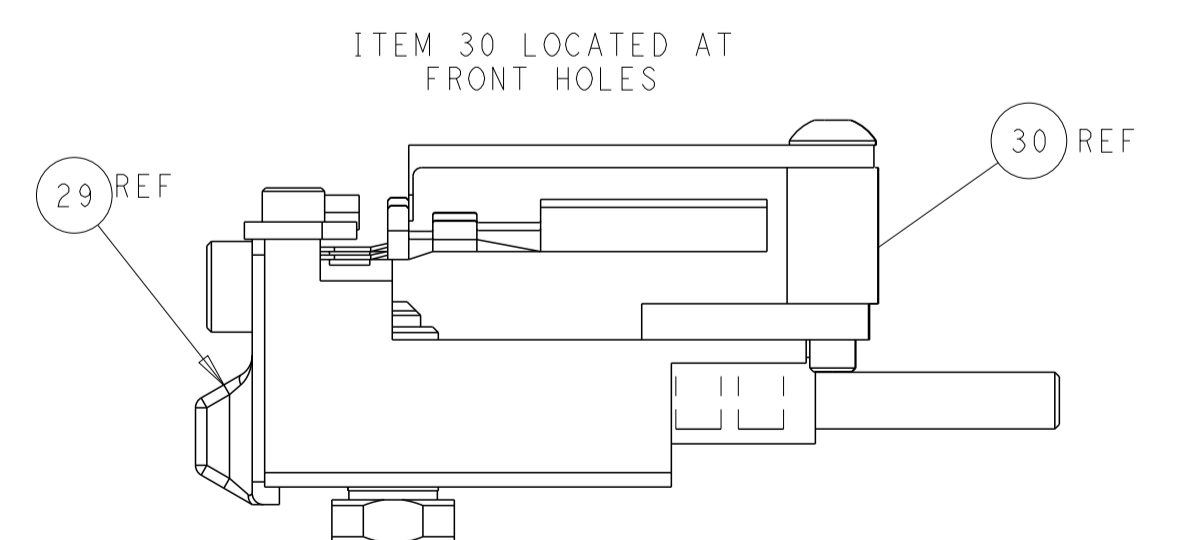

ITEM 30 LOCATED AT FRONT HOLES

CAM POSITIONS

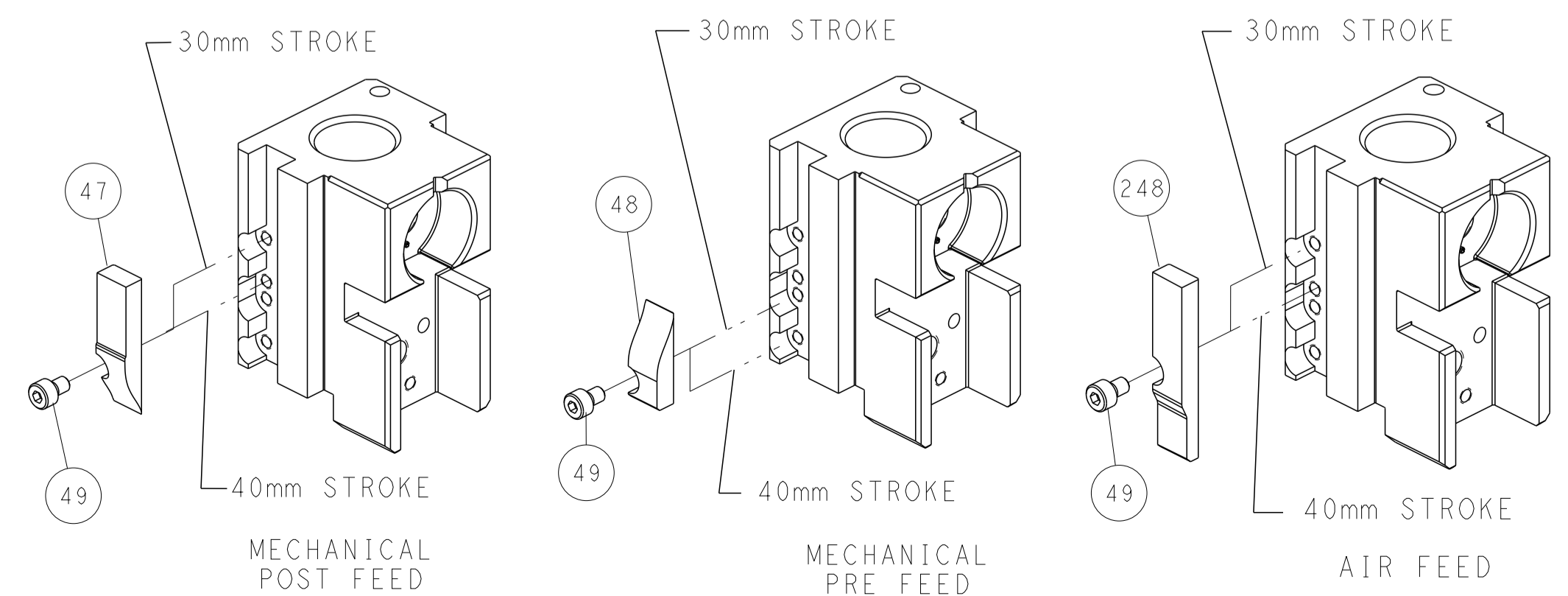

ATLANTIC VERSION
 Shown on sheets 1 of 4 & 2 of 4
 (Pacific version shown on sheets 3 of 4 & 4 of 4)

<small>THIS DRAWING IS UNPUBLISHED. RELEASED FOR PUBLICATION BY TYCO ELECTRONICS CORPORATION. ALL RIGHTS RESERVED.</small>		DWN: R. HUANG 06JUN2012 CHK: S. XI 06JUN2012 APVD: S. XI 06JUN2012 PRODUCT SPEC: - APPLICATION SPEC: - WEIGHT: - MATERIAL: -	NAME: Ocean Side Feed Applicator SIZE: A1 CAGE CODE: 00779 DRAWING NO: 2151457 SCALE: 1:2 SHEET: 2 OF 4 REV: C	TE Connectivity Harrisburg, PA 17105-3608
--	--	--	--	--

PART NUMBER	REVISION	DESCRIPTION	FEED TYPE
2-2151457-1	C	FINE CRIMP HEIGHT ADJUST	MECHANICAL
2-2151457-2	C	FINE CRIMP HEIGHT ADJUST	PNEUMATIC
7-2151457-7	A	CRIMP TOOLING KIT	-

PACIFIC VERSION TERMINATOR
 INTERFACE ADAPTER



APPLICATOR DATA		
CRIMP	SIZE	TYPE
WIRE	2.41 mm [.095]	F
INSUL	4.39 mm [.173]	O
APPLICATOR INSTRUCTIONS 408-35042		

TERMINAL DATA: DELPHI TERMINAL		DELPHI CRIMP SPECIFICATION	
TERMINAL NAME: TAXI TERMINAL M/P 280			
WIRE STRIP LENGTH	INSULATION DIAMETER RANGE		
5.20-6.00 mm [1.205-.236 IN]	Ø		
TERMINAL APPLICATION SPECIFICATION	DELPHI	-	-

TERMINALS APPLIED				
TE TERMINAL	DELPHI TERMINAL	TE SEAL	DELPHI SEAL	CABLE DIAMETER
286755-1	12048159	1949092-1	15324985	1.60-2.15
		1949807-1	15324982	2.03-2.85
		1572716-1	12010293	2.81-3.49
		1572716-3	15324980	2.81-3.49
		1572757-1	12015323	2.03-2.85

WIRE SIZE	CRIMP HEIGHT mm [INCH]	CRIMP HEIGHT REFERENCE SETTING
1.00mm2	1.40+/-0.05 [1.055+/-0.002]	6.8
0.80mm2	1.30+/-0.05 [1.051+/-0.002]	7.9
0.50mm2	1.20+/-0.05 [1.047+/-0.002]	8.9

TERMINAL DATA: DELPHI TERMINAL		TE CRIMP SPECIFICATION	
TERMINAL NAME: TAXI TERMINAL M/P 280			
WIRE STRIP LENGTH	INSULATION DIAMETER RANGE		
5.20-6.00 mm [1.205-.236 IN]	Ø		
TERMINAL APPLICATION SPECIFICATION	NONE	-	-

TERMINALS APPLIED				
TE TERMINAL	DELPHI TERMINAL	TE SEAL	DELPHI SEAL	CABLE DIAMETER
286755-1	12048159	1949092-1	15324985	1.60-2.15
		1949807-1	15324982	2.03-2.85
		1572716-1	12010293	2.81-3.49
		1572716-3	15324980	2.81-3.49
		1572757-1	12015323	2.03-2.85

WIRE SIZE	CRIMP HEIGHT mm [INCH]	CRIMP HEIGHT REFERENCE SETTING
16 AWG OR 1.25mm2	1.48+/-0.05 [1.058+/-0.002]	7.6



- 1. RECOMMENDED SPARE PARTS
- 2. REFER TO SUPPLIED INSTRUCTION SHEET FOR CLEANING, LUBRICATION AND STORAGE OF APPLICATOR.
- 3. APPLY PART NUMBER 2-23419-6 LOCTITE TO THREADS OF ITEM 242.
- 4. CRIMP HEIGHT REFERENCE SETTING WAS THE SETTING USED WHEN THE APPLICATOR WAS QUALIFIED AT THE FACTORY. ADJUSTMENT MAY BE NECESSARY WHEN RUNNING APPLICATOR IN THE FIELD.
- 5. APPLY TORQ-SEAL IN ALLEN SOCKET TO FILL HOLE AFTER FLAT HD HAS BEEN ADJUSTED TO CORRECT HEIGHT AT QUALIFICATION. APPLY #1-23419-5 LOC-TITE TO THREADS.
- 6. UNLESS SPECIFIED OTHERWISE TORQUE VALUES SHALL BE USED PER DOCUMENT, 101-35000.
- 7. This crimp parameter is provided to meet a custom and unique customer requirement. It has been evaluated and is conditionally specified by TE Connectivity. This customized crimp parameter is not listed as an approved application within the terminal manufacturer's specifications. **TE Connectivity expressly disclaims any and all warranties that the product will perform similarly to validated and approved applications, as stated within the manufacturer's application specifications, including but not limited to implied warranties of merchantability or fitness for particular purpose.** As such, it is highly recommended that the customer perform further detailed evaluation to assess product performance in the specific application and obtain approval from terminal manufacturer for this custom requirement.

***WARNING**
 ON INSTALLATION, SET WIRE DISC TO CRIMP HEIGHT REFERENCE SETTING FOR LARGEST WIRE SIZE. CRIMP HEIGHT REFERENCE SETTINGS GREATER THAN THE VALUE SHOWN MAY CAUSE DAMAGE TO THE CRIMP TOOLING. REFER TO THE INSTRUCTION SHEET FOR PROPER SETUP AND ADJUSTMENTS.

LOC	DIST	REVISIONS					
A	66	P	LTN	DESCRIPTION	DATE	DWN	APVD
-	-	-	-	SEE SHEET 1	-	-	-

-	1	1	2119082-2	CAM, SNAIL, INSULATION ADJUSTMENT	244
-	1	1	2079764-1	WASHER, WAVE SPRING, CREST-TO-CREST	243
-	1	1	2119083-1	RETAINER, INSULATION DIAL	242
-	1	1	7-18023-7	SCR, SKT HD CAP M3 X 4.0	241
-	-	1	2119580-1	MECHANICAL FEED ASSEMBLY	239
-	1	-	2844940-1	AIR FEED MODULE	238
-	REF	REF	994970-2	COUNTER, MAGNETIC	164
-	1	-	2119641-2	FEED CAM, AIR FEED	151
-	1	1	2168083-8	SCR, SKT HD CAP, RoHS, M4 X 16	144
-	4	4	2168083-9	SCR, SKT HD CAP, RoHS, M4 X 20	143
-	-	1	2119653-2	FEED CAM, POST FEED	142
-	1	1	1-1803583-0	APPLICATOR BASIC ASSEMBLY, SF	141
-	1	1	1803516-1	RAM ASSEMBLY, SF PACIFIC	140
-	1	1	2844908-1	SCREW, LOCKING	99
-	1	1	2844907-1	POST, LOCKING	98
-	1	1	318563-1	GUARD, FRONT CHIP	89
-	1	1	455888-6	SPACER, CRIMPER	82
-	1	1	1803096-1	EXTENSION PLATE	78
-	1	1	1803607-3	DOCUMENTATION PACKAGE	71
-	1	1	2119740-1	TAG, IDENTIFICATION	67
-	2	2	2168078-1	SCREW, DRIVE, RH, RoHS, 2 x .188	66
-	1	1	5-18022-5	SCR, HEX HD CAP, M4 X 6.0	59
-	1	1	985575-3	SCR, FLT SKT HD CAP M3 X 10.0	57
-	1	1	1338685-1	PAWL, FEED	56
-	2	2	2168083-8	SCR, SKT HD CAP, RoHS, M4 X 16	53
-	1	1	5018030-1	NUT, HEX, REG, RoHS, M3	52
-	1	1	811242-5	BUMPER, HOLD DOWN	51
-	1	1	690753-2	SPACER, TONKER	50
-	1	2	18023-9	SCR, SKT HD CAP M4 X 6.0	49
-	-	1	2119652-1	FEED CAM, PRE FEED	48
-	1	1	1803602-1	SCR, BHSC, RoHS (M8 X 25)	41
-	1	1	1752356-3	SUPPORT, TERMINAL	34
-	2	2	2079383-5	SCR, BHSC, RoHS (M4 X 20)	33
-	2	2	1-2844962-7	SPACER, CYLINDRICAL, STRIP GUIDE	30
-	1	1	2844992-1	ASSEMBLY, STRIP GUIDE	29
-	1	1	455888-3	SPACER, CRIMPER	28
-	1	1	1320928-4	STRIP GUIDE	24
-	1	1	2168083-2	SCR, SKT HD CAP, RoHS, M4 X 8.0	21
-	1	1	1-18028-2	WASHER, FLAT, REG M4	20
-	1	1	2119533-1	STRIPPER, SIDE FEED	19
-	1	1	2119806-1	INSERT, SHEAR	13
-	1	1	3-22280-3	SPRING, COMPRESSION	12
-	1	1	1-356885-4	STOP, SHEAR	11
-	1	1	2119805-1	SHEAR HOLDER, FRONT	10
-	1	1	318707-1	FLOATING SHEAR, FRONT	9
-	1	1	1633905-7	ANVIL, COMBINATION	8
-	1	1	240641-4	SPACER	7
-	-	-	-	-	6
-	1	1	2119781-1	DEPRESSOR, SHEAR	5
-	1	1	238011-2	BLOCK, CRIMPER SPACER	4
-	1	1	4-1633965-2	CRIMPER, INSULATION O PREMIUM	3
-	1	1	455888-6	SPACER, CRIMPER	2
-	1	1	7-1490019-5	CRIMPER, WIRE PREMIUM	1

PACIFIC VERSION
 Shown on sheets 3 of 4 & 4 of 4
 (Atlantic version shown on sheets 1 of 4 & 2 of 4)

DIMENSIONS:		TOLERANCES UNLESS OTHERWISE SPECIFIED:		DWG		REV	
mm	0 PLC ±	1 PLC ±	2 PLC ±	3 PLC ±	4 PLC ±	APVD	DATE
	ANGLES	FINISH		H. HUANG	06JUN2012	S. XI	06JUN2012
MATERIAL				NAME	Ocean Side Feed Applicator		
				SIZE	CAGE CODE	DRAWING NO	RESTRICTED TO
				A1	00779	2151457	
				Customer Accessible Production Drawing	SCALE	1:2	SHEET 3 OF 4

LOC	DIST	REVISIONS					
A	66	P	LYN	DESCRIPTION	DATE	DWN	APVD
		-	-	SEE SHEET 1	-	-	-

FEED TYPE MECHANICAL

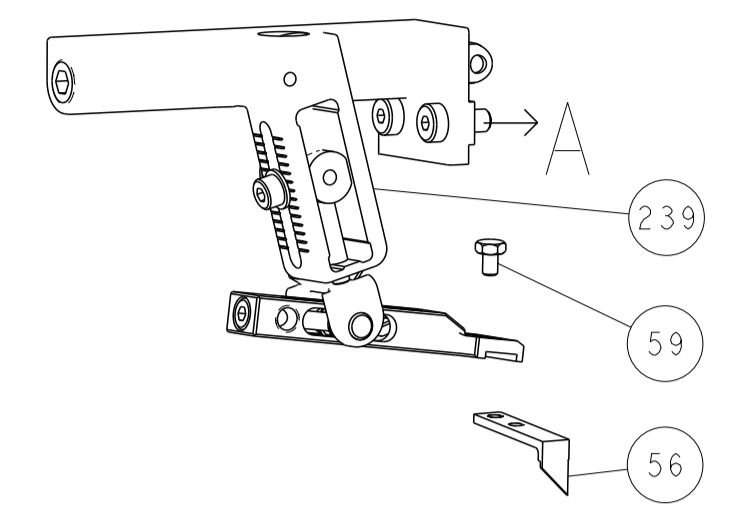

PNEUMATIC

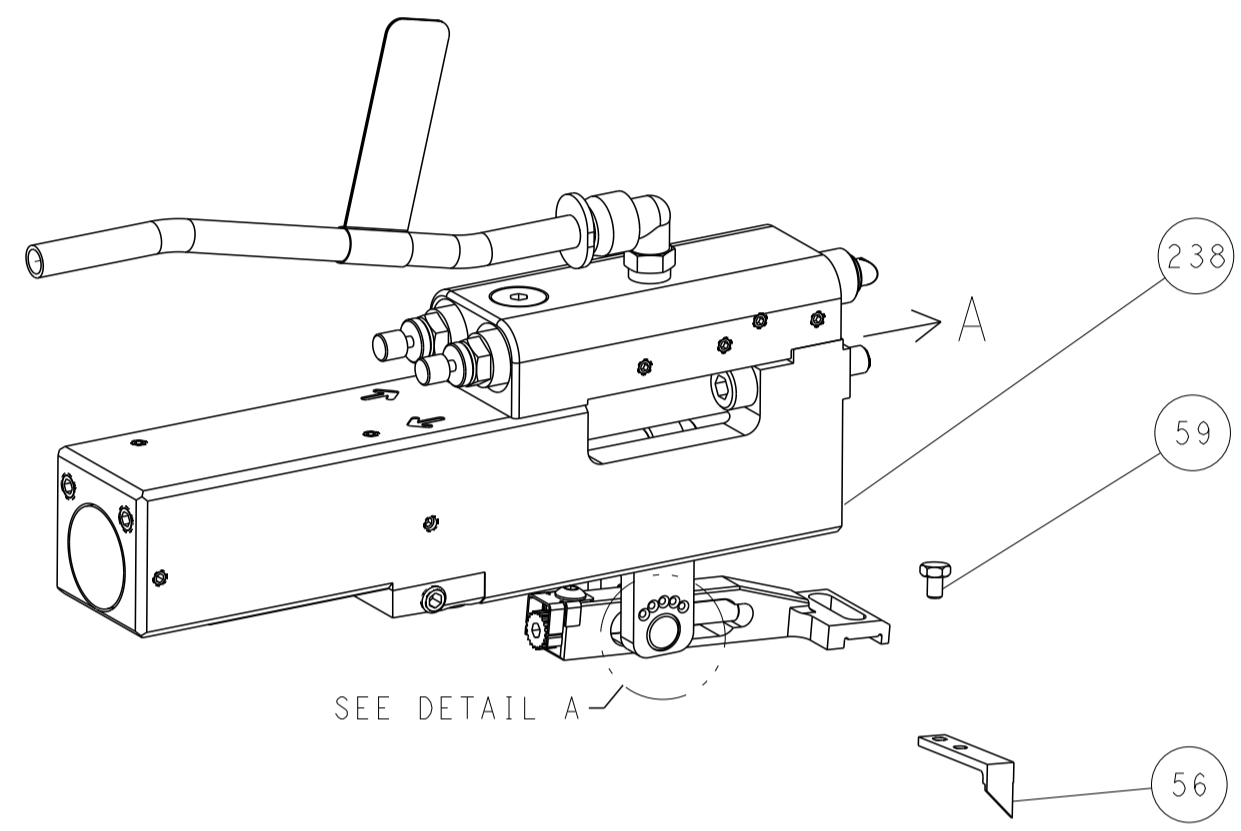

FEED SPRING SETTING POSITION (SHOWN FROM REAR SIDE)

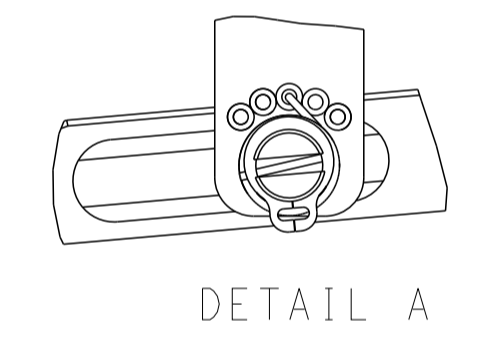

CAM POSITIONS

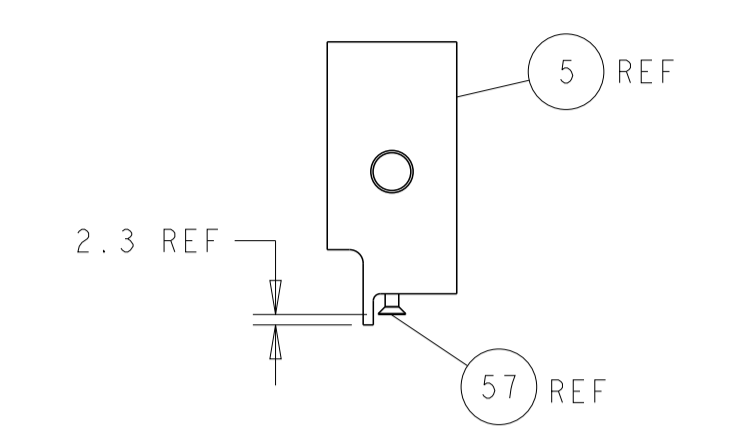
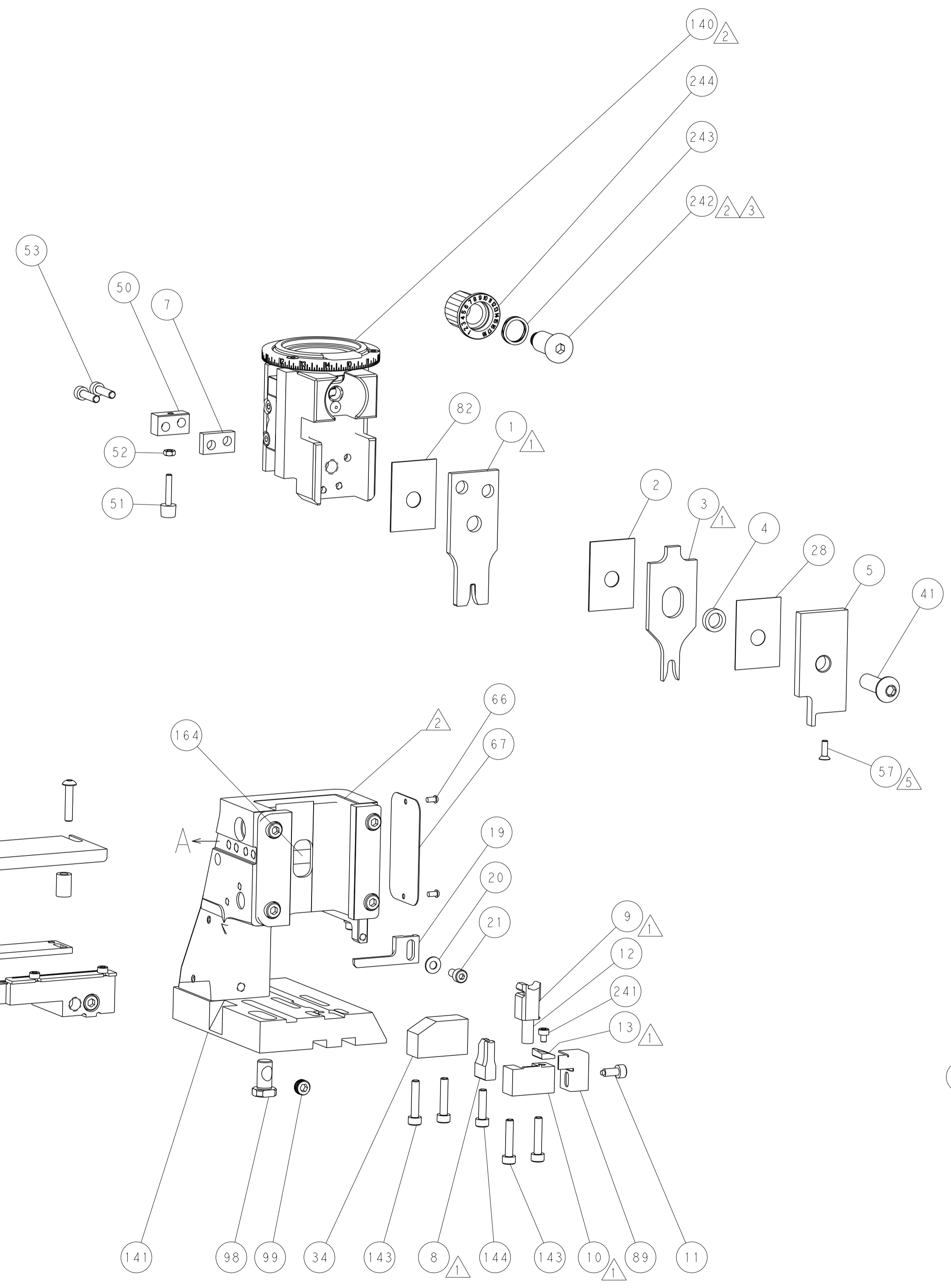
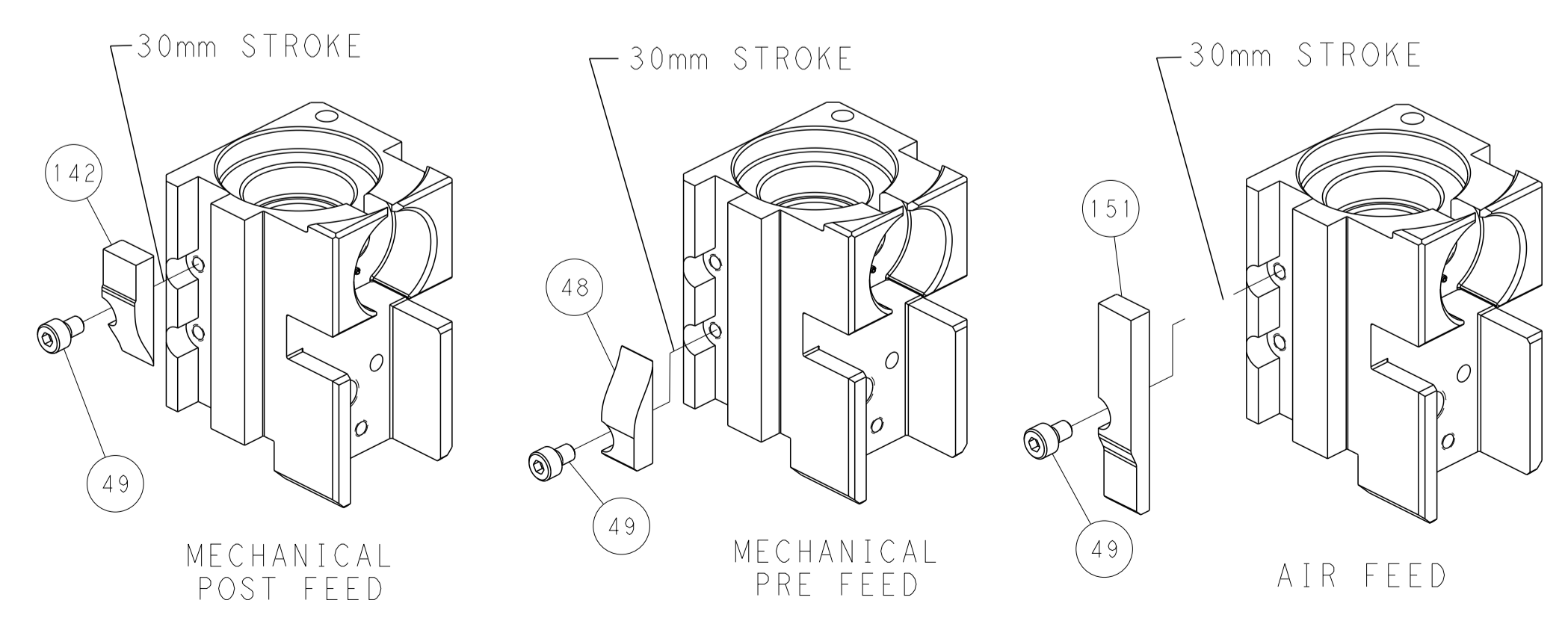

SHEAR DEPRESSOR DETAIL

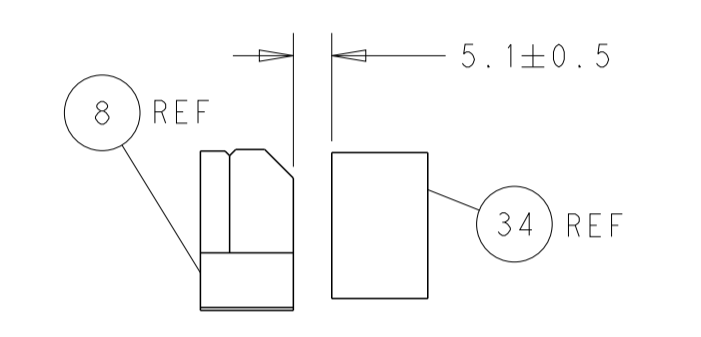

TERMINAL SUPPORT LOCATION

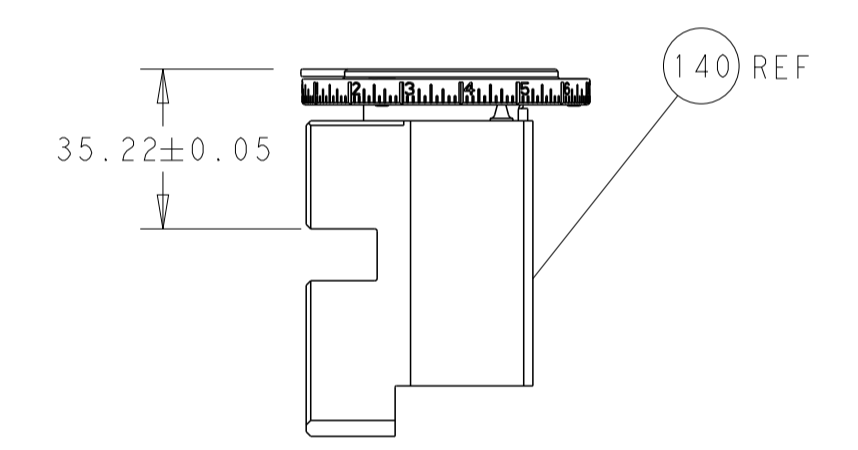

RAM SET-UP

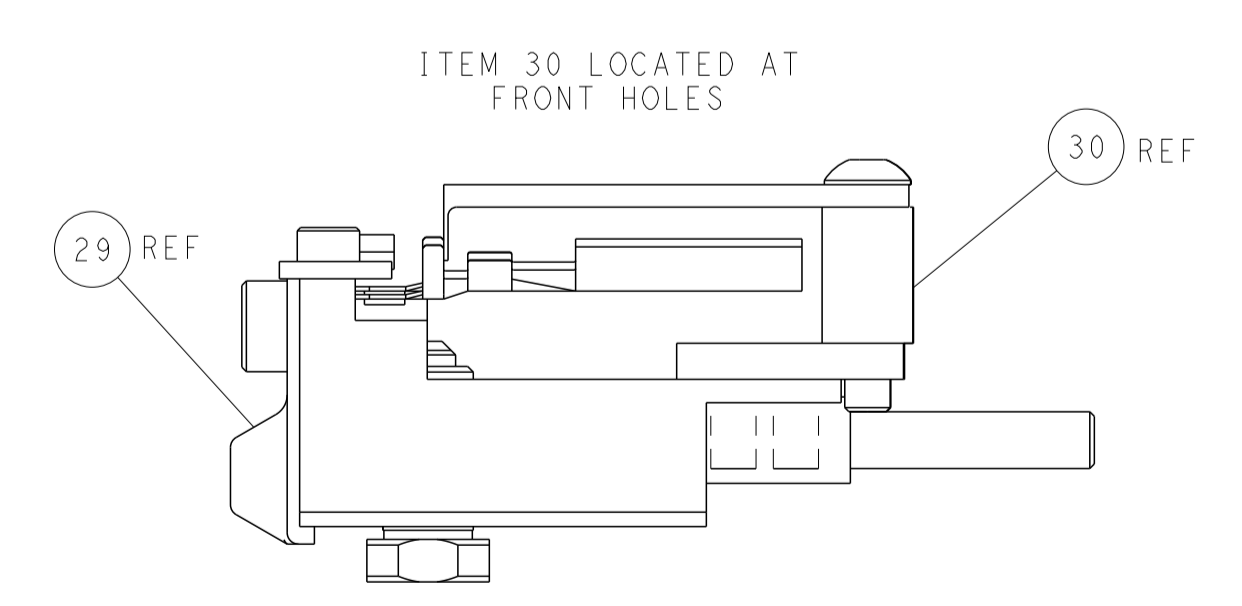

FEED TRACK POSITION GUIDE BY INSULATION BARREL

PACIFIC VERSION
 Shown on sheets 3 of 4 & 4 of 4
 (Atlantic version shown on sheets 1 of 4 & 2 of 4)

DIMENSIONS: mm 		TOLERANCES UNLESS OTHERWISE SPECIFIED: 0 PLC ± 1 PLC ± 2 PLC ± 3 PLC ± 4 PLC ± ANGLES ± FINISH		DWN R. HUANG 06JUN2012 CHK S. XI 06JUN2012 APVD S. XI 06JUN2012 PRODUCT SPEC APPLICATION SPEC WEIGHT Customer Accessible Production Drawing		NAME Ocean Side Feed Applicator SIZE CAGE CODE DRAWING NO. A1 00779 C=2151457 RESTRICTED TO	
MATERIAL		SCALE 1:2		SHEET 4 OF 4		REV C	